



Office of the Chief Economist
U.S. DEPARTMENT OF AGRICULTURE

Renewable Energy Trends, Options, and Potentials for Agriculture, Forestry, and Rural America





How to Obtain Copies:

You may electronically download this document from the U.S. Department of Agriculture's Web site at:

<https://www.usda.gov/sites/default/files/documents/renewable-energy-trends-2020>

For Further Information, Contact:

Jan Lewandrowski, USDA-OCE Project Manager (jan.lewandrowski@usda.gov)

Bill Hohenstein, Director, USDA-OCE Office of Energy and Environmental Policy (william.hohenstein@usda.gov)

Diana Pape, ICF Project Manager (diana.pape@icf.com)

Suggested Citation:

Schultz, Craig, D. Man, J. Rosenfeld, M. McCurdy, M. Anderson, K. Jaglo, B. Goossen, M. Kaffel, J. M. Farrell, F. Wissell, T. Hendrickson, J. Lukas, T. Buchholz, I. M. Xiarchos, W. Hanson, J. Lewandrowski, D. Pape, 2021. Renewable Energy Trends, Options, and Potentials for Agriculture, Forestry, and Rural America. March 2021. U.S. Department of Agriculture, Office of the Chief Economist.

This report describes conditions and trends observable in renewable energy markets over the period 2000 through 2019. All data, Government and private sector reports, peer reviewed literature, and other materials cited in this report are publicly available. Events that have impacted renewable energy markets since the beginning of 2020, including the COVID-19 pandemic, are not reflected in this report.

Any views presented in this paper are those of the authors and do not represent the views of USDA.

Use of commercial and trade name does not imply approval or constitute endorsement by USDA.

USDA is an equal opportunity provider, employer, and lender.



Table of Contents

Executive Summary	1
1. Introduction	26
2. Public Policies to Incentivize Adoption of Renewable Energy in Agriculture, Forestry, and Rural America	28
Historical Policy Development (1970–2009)	28
Current Policy Landscape (2010–2020)	31
Future Direction and Intended Impacts of Current Policies	38
References	40
3. Bioelectricity	43
Technology Characterization	44
Current Level and Cost of Adoption and Regional Distinctions	48
Adoption Impacts	60
Dominant Ownership/Financing Model	65
Anaerobic Digesters	65
Challenges to Extending Adoption	71
References	73
4. Solar Energy	79
Technology Characterization of PV	80
Current Level and Cost of Adoption and Regional Distinctions for PV	84
Adoption Impacts of PV	92
Dominant Ownership/Financing Model For PV	96
Battery Energy Storage: Supporting Technology	98
Solar Water and Air Heating Systems	99
Challenges to Extending Adoption	102
References	104
5. Wind Energy	108
Technology Characterization for Utility-Scale Systems	109
Current Level and Cost of Adoption and Regional Distinctions	111
Dominant Ownership/Financing Model for Utility-Scale Systems	122
Distributed Wind Energy Systems	123
Challenges to Extending Adoption	125
References	126
6. Corn Ethanol Refineries	130
Corn Feedstock Characterization	130
Technology Characterization	131
Current State of Adoption and Regional Distinctions	134
Adoption Costs	136



Adoption Impacts.....	138
Dominant Ownership/Financing Model.....	140
Policies to Encourage Adoption	140
Challenges to Extending Adoption	145
References.....	148
7. Biodiesel and Renewable Diesel	152
Technology Characterization	154
Biodiesel Feedstocks.....	157
Current State of Adoption and Regional Distinctions	159
Adoption Costs.....	161
Adoption Impacts.....	164
Dominant Ownership/Financing Model.....	165
Policies to Encourage Adoption	165
Challenges to Extending Adoption	169
References.....	172
8. Agriculture and Forestry Energy Crops	176
Bioenergy Crops and Their Renewable Energy Uses.....	178
Availability and Current Production of Bioenergy Crops.....	184
Favorable Locations for Production	187
Production and Use Costs and Potential Environmental and Land Use Impacts.....	189
References.....	193
9. Wood Pellets and Wood Chips.....	198
Renewable Energy Uses.....	198
Availability of Wood Pellets and Wood Chips.....	204
Input and Production Costs and Potential Environmental and Land Use Impacts.....	207
References.....	210
10. Conclusion.....	212
State of Renewable Technologies.....	212
Growth of Renewable Energy Technologies (2000–2019)	214
Geographic Distribution.....	215
Cost of Renewable Technologies.....	217
Key Renewable Energy Policies and Incentives	219
The Future of Renewable Technologies for the Agriculture and Forestry Sectors	221
References.....	224

Executive Summary

PURPOSE OF THE REPORT

The continued growth of renewable energy in the United States offers significant economic opportunities for the agricultural and forestry sectors and rural communities. From wind energy systems alone, rural landowners now receive \$289 million in annual lease income (DOE, 2019a). The solar photovoltaic (PV) industry has expanded 800-fold nationally since 2008 and also offers lease payments for landowners hosting large-scale systems, many of whom are in rural areas (EIA, 2020a, table 6.1.A; EIA, 2019a). Smaller PV systems can be used by businesses or households on-site to reduce power bills in many parts of the country. Corn ethanol annual production has risen tenfold since 2000, with national production now at 16 billion gallons and ethanol accounting for almost 40 percent of domestic corn production (USDA, 2019a, tables 10 and 16; USDA, 2018a). In percentage terms, U.S. biodiesel production (primarily from soybean oil) has grown 200-fold over that period and now stands at 1.7 billion gallons annually (EIA, 2020b, table 10.4). There are many more examples of direct economic benefits that agricultural and forestry businesses gain from expanding markets for renewable energy products (including transportation fuels, electricity, and heat) and their feedstocks. These examples are reviewed throughout the report.

Beyond direct economic benefits, renewable energy often enhances energy independence and security, improves wildfire protection, and reduces greenhouse gas (GHG) emissions. Corn ethanol and biodiesel production reduce U.S. reliance on imported petroleum products by billions of gallons per year, while the use of renewable resources for power production can increase the resiliency of agricultural businesses against grid power outages. Forest thinning, through the collection of dead and diseased wood for use as a feedstock for biomass power generation, can substantially reduce wildfire risks. Renewable energy technologies can improve the environment compared to conventional energy technologies. Recent studies have assessed the life cycle GHG emissions of corn ethanol at nearly 40 percent lower than the life cycle emissions of gasoline (Rosenfeld, et al., 2018, p. 99). Among electricity technologies, solar, wind, and sustainably produced biomass substitute zero GHG emission sources for conventional electricity production that is heavily reliant on fossil fuels in much of the country.

There are also potential negative environmental and land use impacts associated with renewable energy growth. For example, expanding bioenergy feedstock production, such as corn for ethanol and soybeans for biodiesel, may lead to conversion of pasture and grasslands to actively managed croplands (EPA, 2018, p. 111). Doing so may negatively affect soil quality, water quality, water availability, and land use patterns in some regions (EPA, 2018, pp. 113-114). Among electricity technologies, negative impacts can include large amounts of water consumption during the operation of biomass power generation systems, increased bird and bat mortality and disrupted migration patterns from wind turbines, conversion of land from agriculture and other uses to host utility-scale PV systems, and introduction of hazardous materials into the environment if PV panels and batteries are not carefully disposed of or recycled. In each case, mitigation practices exist and can be followed to reduce or eliminate negative environmental or land use effects that otherwise might accompany the future growth of these renewable energy technologies.

The markets for renewable energy vary geographically, and all regions have a leading role in one or more types of renewable energy. The Midwest is the center of corn ethanol and biodiesel production, as well as a major source of wind electricity, while the Southeast leads in wood pellet and biomass electricity production markets. The Southeast also has substantial solar production, although the Southwest, including California, leads the national solar electricity industry. Due to its high power prices and strong State incentives, the Northeast also has a large solar market, while the Pacific Northwest has among the most potential for growth in certain forestry and agricultural energy crops.

Given the pace, importance, and variation in renewable energy growth, it is important to have a unified, credible source of information on how renewables can be expected to affect the agricultural and forestry sectors and rural communities, as well as the role Federal and State policies can play in advancing the prudent development of renewable technologies. To this end, the U.S. Department of Agriculture's (USDA's) Office of Energy and Environmental Policy (in the Office of the Chief Economist) supported the development of this report in collaboration with ICF as a synthesis of the current state of renewable energy technologies and as a resource to help address policy and market questions that the agricultural and forestry sectors, government agencies, and other entities may have concerning renewable energy.

ORGANIZATION OF THE REPORT

Following this Executive Summary and a chapter on the impact of Federal and State policies on the growth of renewable energy markets and systems, this report is organized around profiles of major renewable energy technologies and feedstocks. It emphasizes technologies that are commercially viable today and has the chapters shown below. Each chapter provides a technical description of the key technologies and processes, and a synthesis of the current status of deployment, market size and growth, regional distinctions, costs, public policies, and future deployment challenges.

- Bioelectricity
- Solar
- Wind
- Corn Ethanol Refineries (including corn feedstocks)
- Biodiesel and Renewable Diesel Refineries (including soybean feedstocks)
- Agricultural and Forestry Energy Crops
 - Agricultural: Miscanthus and Switchgrass
 - Forestry: Poplar and Willow
- Wood Pellets and Wood Chips

In each chapter, there is an emphasis on how the technology or feedstock is applied more broadly within the agricultural and forestry sectors and rural America. The concluding chapter integrates renewable energy trends into a view of how these technologies and feedstock markets may grow in the future; how public policies can affect that growth; and what market trends will mean for agriculture, forestry, and rural economies going forward.

RENEWABLE ENERGY POLICIES

The renewable energy technologies and feedstocks reviewed in this report have been shaped significantly by Federal and State policies. Those policies, in many cases, were essential for technologies to achieve economies of scale and become cost-competitive with conventional energy sources.

Broadly, renewable energy policy in the United States grew out of a need to respond to national security and environmental concerns that emerged in the 1970s. The renewable liquid biofuels industry is driven at the State level by blending mandates, low carbon fuel standards (LCFS), and alternative fuel standards, and at the Federal level by the Renewable Fuel Standard (RFS). For corn ethanol, all U.S. States achieved average blending levels (ethanol as a percentage of ethanol plus gasoline) greater than 9 percent for the first time in 2015, with most States achieving blending levels of approximately 10.4 percent (EIA, 2017). LCFS policies have been influential due to the aggregate size of participating States (e.g., California and Oregon) and the trend toward more States considering or starting to implement similar programs.

To help support the development of renewable liquid biofuels and their infrastructure, grant, loan guarantee, and other programs from both the USDA and the U.S. Department of Energy (DOE) also have provided vital financial assistance to spur development and adoption of biofuels.

Important Federal renewable electricity policies began in the 1970s, including the Public Utility Regulatory Policies Act of 1978 (PURPA) and the Energy Tax Act of 1978. PURPA contained utility purchase obligations enabling renewable systems not owned by utilities to more readily enter electricity markets. The Energy Tax Act initiated, and the Energy Policy Act of 1992 expanded, tax credits, which became the most widespread Federal renewable electricity incentive and continue to have major effects on solar and wind energy markets. USDA and DOE also offer incentive policies focused on the agricultural sector, such as USDA's Rural Energy for America, Community Wood Energy and Wood Innovation, and Rural Energy Savings programs.

At the State level, the most influential electricity policies have been Renewable Portfolio Standards (RPS) and Clean Energy Standards (CES), which mandate that renewable electricity (or other clean energy sources) comprises a set percentage of a State's electricity generation each year. In some States, these requirements rise to 100 percent in future years, creating the necessity of continued renewables growth. In other States, RPS or CES targets can be much lower, can be goals rather than mandates, or not exist at all.

The combined impacts of policies, technology improvements in cost and performance, the price of non-renewable energy sources, and renewable resource availability on national renewable market growth and its regional deployment patterns are summarized in the balance of the Executive Summary and throughout the report.

COMPARISONS OF RENEWABLE ENERGY TECHNOLOGIES AND FEEDSTOCKS

Key attributes of five renewable energy technologies and four feedstocks profiled in this report are compared in three tables:¹

- *Exhibit ES-1*, with three renewable electricity technologies: bioelectricity, solar PV, and wind
- *Exhibit ES-2*, with two biorefinery technologies: corn ethanol and biodiesel
- *Exhibit ES-3*, with two agricultural energy crops (switchgrass and Miscanthus) and two forestry energy crops (poplar and willow)

Due to the great variation in how renewable technologies are deployed and feedstocks are managed, cost data in these comparison tables should be viewed as broad estimates. Unless otherwise noted, cost data in the summary tables and the balance of the report have not been adjusted to 2020 dollars. The first table, *exhibit ES-1*, applies to renewable electricity generation technologies.

EXHIBIT ES-1: Comparison of Renewable Electricity Technologies²
(data are national and correspond to all system sizes unless otherwise noted)

Attribute	Bioelectricity ³	Solar PV	Wind	References
U.S. Generating Capacity (MW _{AC})	15,563	58,782	105,583	See technology profiles later in this chapter
Annual U.S. Electricity Production in 2019 (GWh)	58,412	104,057	300,071	EIA, 2020a, table 1.1.A
Share of U.S. Electricity Production (Renewable & Non-Renewable Combined) in 2019 ⁴	1.4%	2.5%	7.2%	EIA, 2020a, tables 1.1 & 1.1.A

¹ Two additional feedstocks—wood pellets and wood chips—are profiled in this report and in the Executive Summary; however, they do not have a comparison data table. This is due to the interdependency of the wood pellet and chip markets, which make side-by-side comparisons difficult to interpret.

² The units of measure and acronyms used in this exhibit and their equivalencies are as follows: 1 megawatt (MW) = 1,000 kilowatts (kW); 1 gigawatt-hour (GWh) = 1,000 megawatt-hours (MWh) = 1,000,000 kilowatt-hours (kWh); MMBtu = million British thermal units; DC = direct current; AC = alternating current; CO₂e = carbon dioxide equivalent.

³ Total generating capacity, annual production, and share of U.S. total electricity production include biogas and biomass sources.

⁴ The denominator for this calculation is all U.S. utility-scale electricity production plus U.S. small-scale PV production.

Attribute	Bioelectricity ³	Solar PV	Wind	References
Capital Cost (\$/kW) ⁵	Utility Scale: \$2,000 – \$5,000 (in \$/kW _{AC})	Residential Scale: \$3,500 – \$4,200 Commercial Scale: \$2,200 – \$3,000 Utility Scale: \$1,140 (all PV in \$kW/ _{DC})	Utility Scale: \$1,100 – \$1,500 Small & Mid-Sized Distributed Scale: \$2,500 – \$8,000 (in \$/kW _{AC})	See technology profiles later in this chapter
Fixed Operations and Maintenance (O&M) Cost (\$/kW) in Year 1 of System Operation ⁶	Utility Scale: \$50 – \$110	Residential Scale: \$14 – \$25 Commercial Scale: \$15 – \$20 Utility Scale: \$9 – \$12	Utility Scale: \$26 – \$36	
Variable, Non-Fuel O&M Cost (\$/kWh)	Utility Scale: \$0.005	N/A	Small cost; data not readily available	USDA, 2014, p. 8
Fuel Costs (\$/MMBtu)	Utility Scale: \$1 – \$2	N/A	N/A	Lazard, 2017, p. 19
Levelized Cost of Energy (\$/kWh) ⁷	Utility Scale: \$0.055 – \$0.114	Residential Scale: \$0.151 – \$0.242 Commercial Scale: \$0.075 – \$0.154 Utility Scale: \$0.032 – \$0.044	Utility Scale: \$0.028 – \$0.054	Lazard, 2017, p. 19; Lazard, 2019, p. 3
U.S. Employment	13,178 ⁸	248,034	114,774	NASEO, 2020, pp. 56, 60, & 81
Annual GHG Emission Reductions From a 10-MW _{AC} System in Example States (metric tons of CO ₂ e) ^{9,10}	KY: 60,179 FL: 31,069 WA: 6,555 (assuming biomass as carbon neutral)	KY: 18,236 FL: 9,415 WA: 1,986	KY: 25,385 FL: 13,106 WA: 2,765	See detailed descriptions in Bioelectricity, Solar, and Wind chapters
Baseload Generation Source ¹¹	Yes, if feedstock supply is stable	No	No	N/A

Exhibit ES-2 summarizes two significant renewable liquid biofuel technologies: corn ethanol and biodiesel. Renewable diesel (RD) is a subset of the biodiesel category, and RD data are broken out separately, where appropriate.

⁵ Capital costs are the all-in upfront costs (including design, engineering, equipment, labor, permitting, financing, and commissioning) of installing an electricity generation system (before incentives). *Residential scale* refers to small systems at typical households; *commercial scale* corresponds to mid-sized systems at agricultural, forestry, or other commercial or industrial facilities; and *utility scale* refers to the largest systems used to produce power for resale in wholesale electricity markets (by utilities or other generation suppliers).

⁶ Fixed O&M costs for power generation systems typically increase annually after year 1 with general price inflation.

⁷ Levelized cost of energy (LCOE) is a metric to compare the long-term costs of generating electricity from different renewable and non-renewable sources. LCOE combines capital costs, O&M costs, system performance (how much electricity is produced annually relative to capacity), and risk-adjusted expected investment returns. The LCOE data shown are without Federal incentives.

⁸ This may not include employees at biomass-fueled combined heat and power plants, which are counted separately (NASEO, 2020, p. 63).

⁹ The differences among States in estimated GHG emission reductions from renewables are due to the different carbon intensities of their existing mixes of power generation sources. For example, Kentucky has a relatively coal-intensive generation mix and, therefore, introduction of renewables leads to particularly large reductions in GHG emissions in that State.

¹⁰ The differences among renewable technologies in estimated GHG emission reductions are due to different capacity factors. Capacity factor measures the annual production of an electricity generation technology relative to its potential production if it operated at its full rated capacity all year. Bioelectricity technologies have the highest average capacity factors because they do not depend on variable sunlight or wind for their power.

¹¹ Baseload electricity can be generated at consistent levels over long periods. If a biomass power generation system has a reliable, long-term feedstock supply and operational plan, it should be able to serve as a baseload power plant. In contrast, without a means of storing electricity, power from wind and PV systems can vary minute to minute with the availability of wind and sunlight.

EXHIBIT ES-2: Comparison of Renewable Liquid Biofuel Technologies
(data are national and correspond to all system sizes unless otherwise noted)

Attribute	Corn Ethanol	Biodiesel	References
Annual U.S. Production Volume (gallons)	16 billion	Biodiesel: 1.7 billion Renewable Diesel: Not reported ¹²	USDA, 2019a, tables 10 & 16; EIA, 2020b, table 10.4; EIA, 2019b
Fuel Yield	490 gallons/ acre of corn ¹³	57 gallons/ acre of soybean	AGMRC, n.d.
Capital Cost of Representative Refinery ¹⁴	> \$211 million ¹⁵	\$47 million	Hofstrand, 2020; Hofstrand, 2019
Feedstock Cost (\$/gallon)	\$1.34	\$2.38	
Variable Fossil Fuel Input Cost (\$/gallon)	Natural gas: \$0.14	Natural gas: \$0.04 Methanol: \$0.13	
Variable, Non-Feedstock and Non-Fuel O&M Cost (\$/gallon)	\$0.22	\$0.25	
Fixed O&M Cost Over the Asset Life (\$/gallon of capacity) ¹⁶	50 MMGPY: ¹⁷ \$0.43 100 MMGPY: \$0.21	\$0.26	
Co-Product Revenue Over the Asset Life (\$/gallon of capacity)	\$0.41 ¹⁸	N/A	
Levelized Cost of Fuel (\$/gallon) ¹⁹	50 MMGPY: \$1.72 100 MMGPY: \$1.50	\$3.06	
U.S. Employment	68,684 direct jobs in 2019	2,500 direct jobs in 2017	

Due to high production costs, the four agricultural and forestry energy crops summarized in *exhibit ES-3* are not extensively used for energy production at this time, although they have physical characteristics and widespread availability that make them conducive to energy use. Because these feedstocks are not yet widely produced for energy use, cost data tend to be based on limited analyses.

¹² The annual production capacity of renewable diesel plants in the United States was 356 million gallons as of 2018, not including a renewable jet fuel plant (DOE, 2020a).

¹³ A corn crop yield of approximately 170 bushels per acre is assumed (USDA, 2020a).

¹⁴ A 15-year asset lifetime is assumed.

¹⁵ Costs are associated with a representative ethanol plant, which produces ethanol and dried distillers grain with solubles (DDGS). Capital costs include all costs associated with site preparation, engineering, permitting, financing, and construction.

¹⁶ Fixed O&M costs include maintenance materials and services, direct and indirect labor and benefits, operations management, office and lab expenses, training, travel, and professional consulting fees.

¹⁷ MMGPY = million gallons per year

¹⁸ Co-product revenue is specific to an ethanol plant solely producing DDGS.

¹⁹ The levelized cost of fuel is a metric used to approximate the price at which a fuel would need to be sold to break even with conventional gasoline (in units of US\$ per gallon of gasoline equivalent).

EXHIBIT ES-3: Comparison of Agricultural and Forestry Energy Crops
(data are national unless otherwise noted)

Attribute	Switchgrass	Miscanthus	Hybrid Poplar	Willow	References
Land Area Used for U.S. Production (acres)	978	5,400	639 (in production) 133 (harvested)	Approx. 1,200	See technology profiles later in this chapter
U.S. Annual Production Volume (dry tons)	6,246	41,557	18,951	Not available	
Typical Range of Annual Yields (tons per acre)	2 – 8	7 – 11	1.25 – 8.6	1.6 – 6.3	
Production Cost (2020 \$/dry ton) ²⁰	\$55 – \$97	\$42 – \$90	N/A	N/A	
Production Cost (2020 \$/MMBtu)	N/A	N/A	\$5.33 (Minnesota study)	\$6.22 (Illinois study)	

PROFILES OF RENEWABLE ELECTRICITY TECHNOLOGIES

Three renewable electricity technologies particularly important to the agricultural and forestry sectors and rural America—bioelectricity, solar, and wind—are profiled below. Detailed descriptions of these technologies are found in chapters 3, 4, and 5 of the report, respectively.

Bioelectricity

Technology Description

Biomass feedstocks, in the form of wood, agricultural wastes, and purpose-grown agricultural and forestry crops, are used to produce both electricity and heat. Because electricity generation (termed *bioelectricity*) is the larger application of biomass, it is emphasized in this report. The primary technology for converting biomass feedstocks into electricity is combustion, in which a furnace or boiler produces steam from chipped, shredded, or dried biomass, and the steam drives a turbine that turns a generator to produce electricity.

Another bioelectricity technology is anaerobic digestion (AD), which is used primarily in confined livestock operations and urban settings to extract biogas from animal manure, crop residues, food waste, sewage effluent, and other organic waste streams. The methane in the biogas can be purified and then combusted on-site at the farm in a combustion turbine or reciprocating engine generator to produce electricity and/or heat. There are 255 operating AD systems on U.S. farms, primarily on confined dairy and swine operations (EPA, 2020).

Benefits

Biomass power generation systems can increase feedstock demand, provide employment, reduce energy costs, bring budget certainty (for businesses that consume biomass power on-site), improve wildfire protection (by thinning forests of diseased trees), and reduce GHG emissions (Biomass Magazine, 2020; DOE, 2016a, p. 12).

²⁰ All production costs in this table (in \$/dry ton and \$/MMBtu) are before transportation, processing, and storage. These costs have been adjusted to 2020 dollars.

National Market Size and Trends

Unlike the rapid growth in U.S. PV and wind energy markets over the past decade, power generation from biomass and biogas (jointly *bioenergy*) has been largely flat.²¹ Between 2014 and 2018, net annual electricity production from bioenergy feedstocks declined by 3 percent in aggregate to 61,901 gigawatt-hours (GWh), as seen in *exhibit ES-4* (DOE, 2020b, p. 78).²² Annual production from bioenergy declined further to 58,412 GWh in 2019 (EIA, 2020a, table 1.1.A). Bioenergy power generation capacity in 2018 was 15,563 MW_{AC} (DOE, 2020b, p. 78).

In total, bioenergy power generation systems accounted for less than 2 percent of all U.S. electricity production in 2019, but 8 percent of total renewable electricity production, including hydropower (EIA, 2020a, tables ES1.A and 1.1.A).

Regional Distinctions

Bioenergy power production is prevalent in the Southeast, with four of the five largest producing States in 2018, as seen in *exhibit ES-5*. Ample forestry resources are a primary reason for bioenergy system deployment in the Southeast.

California has the most power production from bioenergy due to its widespread agricultural and forestry sectors, high power prices available for biomass systems to offset, and attractive incentive policies.

Costs

The capital costs for deploying utility-scale biomass power generation systems range from \$2,000 to \$5,000/kW_{AC} of capacity (NREL, 2019a; Lazard, 2017, p. 19; EIA, 2016, p. 7; NIBS, 2016; USDA, 2014, p. 8). Smaller-capacity systems often have higher per-kW capital costs. Feedstock costs are typically the most significant operational cost for these systems, with costs of \$1 to \$2/MMBtu (Lazard, 2017, p. 19). In addition to feedstocks, utility-scale biomass systems have fixed annual O&M costs of about \$50 to \$110/kW_{AC} (Lazard, 2017, p. 19; EIA, 2016, p. 13-4; USDA, 2014, p. 8).

Key Policies

Biomass power generation is eligible for a blend of Federal incentives through the tax code and USDA programs. There are Federal investment and production tax credits for different types of biomass power generation systems. USDA-administered incentive programs include the Rural Energy for America Program (grants and loan guarantees), Community Wood Energy and Wood Innovation Program (directed at expanding wood energy markets and reducing wildfire risks), and Rural Energy Savings

EXHIBIT ES-4: U.S. Bioenergy Power Generation Capacity and Annual Production Trends

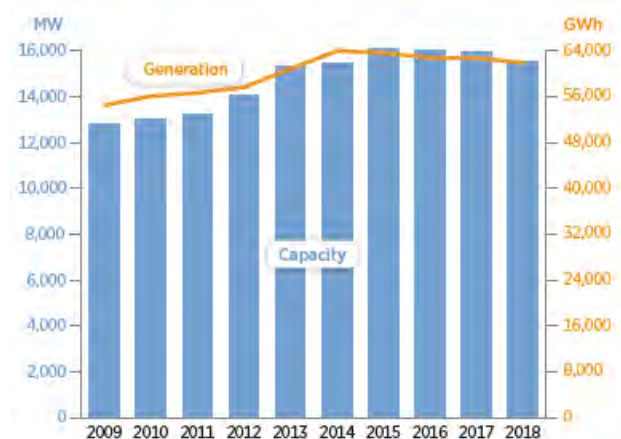

Source: DOE, 2020b, p. 78 (capacity is on the left axis and annual electricity production is on the right axis).

EXHIBIT ES-5: Net Annual Electricity Production From Bioenergy Power Generation Systems

State	Annual Production (GWh)
California	5,946
Florida	5,084
Georgia	4,999
Virginia	4,173
Alabama	3,446
<i>National Total in 2018: 61,901</i>	

Source: Based on EIA, 2020c.

²¹ Bioelectricity production is primarily from wood and wood-derived biomass (68 percent of total), with smaller shares from landfill gas (17 percent), biogenic municipal solid waste (10 percent), and other waste biomass (4 percent) (EIA, 2020a, table 1.1.A).

²² 1 GWh = 1,000 megawatt-hours (MWh) = 1,000,000 kilowatt-hours (kWh)

Program (loans to utilities, cooperatives, and municipalities that re-loan funds to rural households and small businesses) (NARA, 2020; USDA, 2020b; USDA, 2019b).

At the State level, policy support is primarily from RPS and CES mandating increasing levels of renewables deployment. Unlike for solar and wind energy, the eligibility of biomass for these State programs varies by location, and not all biomass-powered systems are included.

Challenges to Extending Adoption

The greatest challenges to increasing deployment of biomass power generation systems are (1) the lack of recent innovations to improve the cost and performance of this technology relative to solar and wind technologies, and (2) the low cost of natural gas fired conventional utility power, which is difficult for biomass systems to be competitive with in most parts of the United States. In addition, the pending expiration of Federal tax credits and lower State-level incentives for biomass systems relative to PV systems are barriers to the growth of biomass power systems.

Solar

Technology Description

The main solar technology used to convert sunlight into electricity—photovoltaic (PV)—is configured similarly for small systems on household rooftops, mid-sized systems at farms and other businesses, and the large utility-scale systems that can cover 500 or more acres. PV systems are comprised of solar modules (also called panels); racking to attach the modules to a roof or ground surface; inverters that convert direct current (DC) energy received from the modules into alternating current (AC) electricity for on-site use or export to the power grid; and "balance of system" components such as wiring, conduit, switching equipment, and a monitoring sub-system.^{23, 24} PV systems mounted on the ground can either have a fixed orientation to the sun or be "tracking" systems that rotate throughout the day to follow the sun's path to capture more solar energy.

Ground-mounted PV systems have direct land area impacts of 6 to 9 acres per MW_{AC} of generating capacity and total land area impacts of 8 to 13 acres per MW_{AC} (NREL, 2013, p. 10). These land use requirements have led to increasing interest in low-impact PV development plans that preserve topsoil and plant vegetation conducive to pollinators and other insects favorable to agriculture at nearby farms (NREL, 2019b).

Benefits

Farmers and other landowners hosting utility-scale PV systems that sell power to the grid receive annual lease payments that are typically \$500 to \$1,000 per acre (NCCETC, 2017, p. 4). For residential- and commercial-scale PV systems providing power on-site, the household or business does not receive land leases, but often benefits from lower electricity costs than it would pay the utility. In addition, PV systems reduce GHG emissions, provide employment, and can enhance energy security (power during grid outages) when paired with battery storage.

National Market Size and Trends

From its level a dozen years ago, total PV generating capacity in the United States has grown 800-fold, from 71 MW_{AC} in 2008 to 58,782 MW_{AC} in 2019 (EIA, 2020a, table 6.1.A; EIA, 2019a). That capacity is split between PV systems at utility scale (61 percent of market) and those serving residential (24 percent), commercial (12 percent), and industrial (3 percent) end-use customers (EIA, 2020d, table 8b). Systems for commercial and industrial customers are jointly called *commercial-scale* systems in this report.

²³ PV systems most commonly operate "on-grid," with an interconnection to the utility network; however, there also are "off-grid" PV systems, without such a connection, performing agricultural functions such as water pumping.

²⁴ In addition to PV, which is the dominant solar energy technology, there are thermal technologies that produce non-electricity products, such as solar water heating, solar air heating, and solar air cooling.

A driver of increased PV deployment has been the sharp drop in system capital costs. Between 2010 and 2018, PV capital costs declined on inflation-adjusted bases by the following:

- 77 percent for utility-scale (fixed-tilt) systems
- 66 percent for commercial-scale systems
- 63 percent for residential-scale systems (NREL, 2018a, pp. 21, 27, and 37, respectively)

Recent declines in capital costs for lithium-ion battery storage have increased the deployment of combined PV + battery systems to offer power during grid outages for residential- and commercial-scale systems and to allow more PV integration into the grid at all scales.

Regional Distinctions

As seen in *exhibit ES-6*, California has, by far, the most PV deployment of any State, with about 35 percent of the national total. Other areas of widespread PV adoption include Hawaii, the Southwest, Texas, and most of the Eastern Seaboard. Strong solar resources are present in all of these areas, except the Northeast, which tends to have attractive financial incentives for solar and higher than average prices for grid power that PV systems can offset.

EXHIBIT ES-6: Solar PV Generation Capacity by State (MW_{AC})

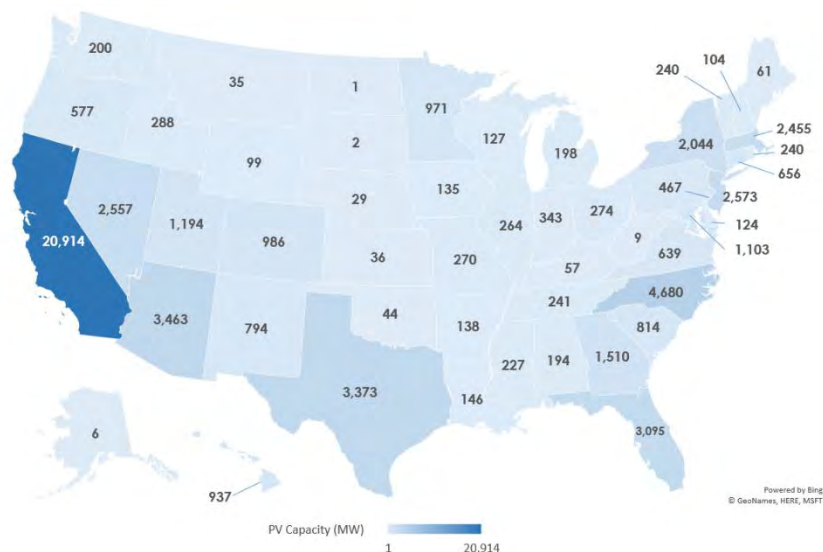

Source: Based on EIA, 2020a, table 6.2.B, with small aggregate differences versus national data in table 6.1.A.

Costs

The primary cost of PV is upfront capital, and there are significant economies of scale. Capital costs typically range from about \$3,500 to \$4,200/kW_{DC} for residential systems and \$2,200 to \$3,000/kW_{DC} for commercial systems (LBNL, 2019, p. 27). For utility-scale systems, the average cost is \$1,140/kW_{DC} (NREL, 2019c, p. 43). Annual O&M costs for PV systems are roughly \$10/kW for utility-scale systems and \$14 to \$25/kW at residential scale (Lazard, 2019, p. 16).

Key Policies

At the Federal level, the most significant incentive is the investment tax credit (ITC) that offsets 26 percent of the capital costs of eligible PV systems. This credit is set to decline to 22 percent in 2021, and 10 percent in 2022 and thereafter for business-owned systems and 0 percent for residentially-owned systems. There also are USDA and DOE solar incentive programs focused on the agricultural

sector. At the State level, PV projects benefit from RPS and CES policies like other eligible renewable energy technologies, but also receive special RPS “carve-outs” in Illinois, Maryland, New Jersey, and other States that further increase compensation.

Challenges to Extending Adoption

The rapid growth of PV over the past decade has brought two challenges—how to cost-effectively integrate higher levels of intermittent power (varying throughout the day) into the power grid and how to preserve agricultural activities in counties where PV occupies large tracts of land. ITC declines also are a near-term challenge to PV economics.

Wind

Technology Description

Wind energy systems comprise one or more turbines, typically each with three blades that rotate like an airplane propeller at a 90-degree angle to the ground. In the United States, almost all turbines are utility scale (with individual generating capacities of 2 to 5 MW). The center of the blades is typically 80 to 140 meters above the ground on tubular steel towers. There are also “distributed” wind energy systems with smaller turbines that have similar designs.

Utility-scale wind energy systems require about 45 acres per MW of capacity, or 135 acres for a 3-MW wind turbine (NREL, 2020). The land is leased from local farmers and other landowners; however, only 1 acre per turbine is removed from long-term farm use (USGS, 2011, p. 16).

Benefits

Wind energy systems provided rural landowners with \$289 million in lease income in 2018 (DOE, 2019a). Roughly equal percentages of wind system capacity are on croplands and rangelands, with 47 percent and 46 percent, respectively (USDA, 2017, table 7).²⁵ The economic benefits for the rural economy from wind system leases are expected to grow as more wind systems are deployed. Beyond direct payments, wind energy systems decrease GHG emissions; provide employment; and, in many markets, reduce the overall electricity prices paid by rural households and businesses.

National Market Size and Trends

There are 105,583 MW of installed wind energy systems in the United States, with national capacity growing more than 40-fold since 2000 (AWEA, 2020, p. 5). That growth has elevated wind's share of total U.S. utility-scale electricity production from less than 1 percent in 2000 to 7 percent currently (EIA, 2020e). Almost all of this growth has occurred among utility-scale systems, with smaller distributed wind systems comprising only 1 percent of the U.S. wind market.²⁶

The growth of the wind industry has been driven by a combination of three factors:

- Technology improvements
- Capital cost reductions
- Incentive policies

Technology advancements include longer turbine blades that can be mounted higher off the ground to capture higher wind speeds and efficiency enhancements in converting a given quantity of wind into electricity. Alongside these technical advances, the total capital costs of utility-scale wind energy systems have declined by about 40 percent over the past decade (DOE, 2019c, p. 51). The Federal production tax credit, together with various State policies, continue to support wind system adoption.

²⁵ The remaining 7 percent of wind systems are on forest (5 percent), barren (1 percent), and developed (1 percent) lands (USDA, 2017, table 7).

²⁶ The cumulative capacity of distributed wind systems was 1,127 MW in 2018, compared to approximately 96,000 MW for the overall wind market in the United States in 2018 and 105,583 MW in 2019 (AWEA, 2020, p. 5; DOE, 2019b, p. 3).

Regional Distinctions

As shown in *exhibit ES-7*, wind system deployment is concentrated in the Plains States, from Texas north to Minnesota and North Dakota, as well as in the Great Lakes region and the West Coast. Systems are least common in the Southeast. The availability of wind resources is a key factor affecting this deployment pattern.

EXHIBIT ES-7: Wind Energy Generation Capacity by State (MW_{AC})

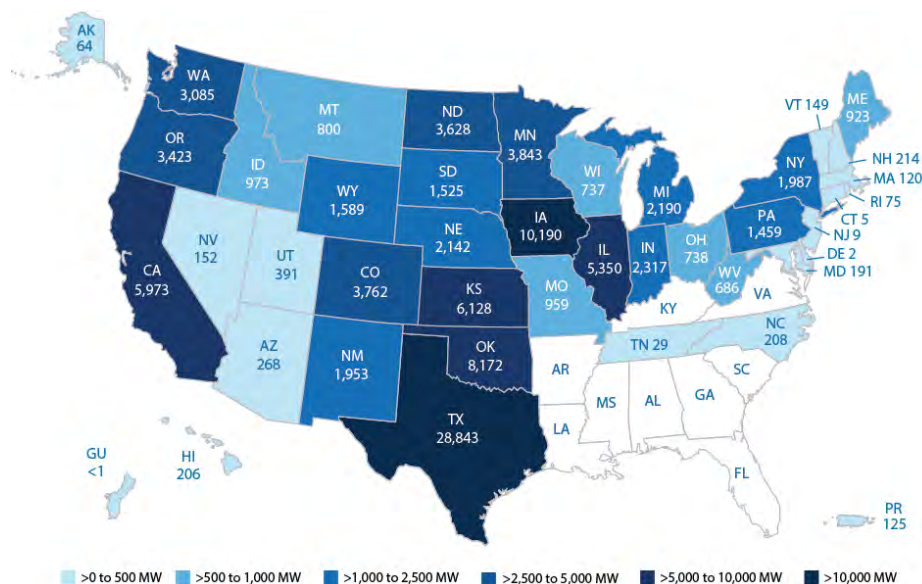

Source: AWEA, 2020, p. 8.

Costs

The pre-incentive capital costs of utility-scale wind systems are \$1,100 to \$1,500/kW_{AC} (Lazard, 2019, p. 17). Distributed wind systems tend to be much more expensive on a unit cost basis, with capital costs of \$2,500 to \$8,000/kW_{AC} for systems of 10 to 750 kW (NREL, 2016, p. 15). O&M represents a relatively small part of the overall cost of wind systems, with annual O&M costing about \$26 to \$36/kW_{AC} for utility-scale systems (EIA, 2020f, p. 2; Lazard, 2019, p. 17).

Key Policies

At the Federal level, the most influential financial incentive is the production tax credit. That incentive policy, which applies to wind energy systems that commence construction or meet safe harbor investment requirements by the end of 2020, currently provides a tax credit beginning at \$0.015/kWh for electricity production for the first 10 years of system operation (IRS, 2019, pp. 2–3). Wind is also eligible for USDA incentive programs. At the State level, RPS and CES policies have provided strong support for wind energy development. As States move toward meeting higher RPS or CES compliance percentages in future years, including up to 100 percent renewables in some States, utility-scale wind energy systems should continue to be a cost-effective solution.

Challenges to Extending Adoption

Although short-term growth in the utility-scale wind energy market is expected to be strong, there are three challenges to continuing that growth past 2024 when most systems qualifying for the Federal production tax credit will have been constructed. The first challenge is determining whether improvements in technology cost and performance will compensate for the loss of the tax credit. The other challenges are how easily electrical grids will be able to integrate increasing shares of intermittently produced wind power without triggering costly load balancing interventions and how quickly leases and permits will be secured as wind turbines continue to become larger.

PROFILES OF RENEWABLE LIQUID BIOFUELS

This section profiles two prominent renewable liquid biofuel technologies: corn ethanol and biodiesel, with renewable diesel included in the summary of biodiesel. Detailed descriptions of these technologies are in chapters 6 and 7 of the report, respectively.

Corn Ethanol

Technology Description

Corn ethanol refining employs two production processes—dry and wet milling. Production facilities utilizing the dry-milling process represent roughly 90 percent of ethanol refining facilities, largely due to the lower capital and operational costs relative to wet-milling plants (DOE, 2018). The most significant distinctions between a dry-milling plant and a wet-milling plant are how the corn is treated at the beginning of the process and the co-products that are produced from each method. Dry milling does not produce any products intended for human consumption, while wet mills produce food grade starch and other products intended for food and beverage use. The initial steps for dry milling consist of the corn being crushed and then combined with water and alpha-amylase enzymes before being heated; for wet milling, the corn is steeped in a sulfurous acid solution for 2 days to break down the corn kernel. Although the initial steps for wet milling and dry milling are different for extracting the starch from the kernel, the steps that follow are similar (Clifford, 2018).

Benefits

When substituted for gasoline, corn ethanol reduces life cycle GHG emissions by 39 percent to 43 percent (Rosenfeld, et al., 2018, p. 99). Co-products from ethanol production have many benefits for the livestock and biodiesel industries. Wet distillers grain with solubles (WDGS) and dried distillers grain with solubles (DDGS) are used as animal feed, which reduces the acreage needed for feed crops. While corn oil also can be used as animal feed, it is often used as a biodiesel feedstock (ANL, 2008, p. 1). The use of corn ethanol as a blending fuel displaces conventional gasoline and increases energy security by reducing dependence on petroleum imports. The economic benefits of the corn ethanol industry include job and income creation, primarily in rural areas. In 2019, the industry employed 68,684 people directly and generated \$23.3 billion in household income (RFA, 2020).

National Market Size and Trends

The United States is the largest producer of ethanol globally, accounting for 56 percent of world production (RFA, 2019, p. 6). In 2018, U.S. ethanol production exceeded 16 billion gallons. Since 2000, when annual production was 1.62 billion gallons, ethanol production has increased tenfold (USDA, 2019a, tables 10 & 16). Over the past several years, ethanol production has been relatively constant, representing roughly 10 percent of total transportation fuel supply. This consistent pattern has been due, in part, to the RFS's implicit cap of 15 billion gallons on annual blending of conventional biofuel from corn starch (i.e., corn ethanol) into the national transportation fuel supply, and an assortment of policies (Federal and State) and other factors that have effectively resulted in a national ethanol blending rate of 10 percent (EIA, 2019b).

Ethanol produced in the United States is predominantly consumed domestically. However, ethanol exports have become more important in recent years, growing from roughly 0.8 million gallons per day in 2014 to roughly 1.6 million gallons per day in 2018 (EIA, 2019b).

Feedstock Market

In 2018, corn production represented approximately 30 percent of all domestic planted acres in the United States (USDA, 2019c, pp. 106-107). Planted corn acres have increased from approximately 78 million acres in 1999 to roughly 92 million acres in 2019 (USDA, 2019d, p. 6; USDA, 1999, p. 18). Corn is primarily used for animal feed, food, seed, and industrial purposes (including fuels). The share of corn grown in the United States that is used as a feedstock for ethanol has increased significantly since the early 1980s and represented nearly 40 percent in 2018 (USDA, 2018a). With the increased demand for ethanol, corn farmers are meeting demand through increasing corn yields, favoring corn in corn-bean rotations, converting existing agricultural land to corn, and converting non-agricultural land

into crop production. Corn yields have increased from roughly 135 bushels/acre in 1998 to nearly 170 bushels/acre in 2019 (USDA, 2020a; USDA, 2018b).

Regional Distinctions

The U.S. corn ethanol industry (i.e., production plants and corn crops) is primarily located in the Midwest, where corn production is concentrated. That region accounts for more than 90 percent of U.S. ethanol production capacity (EIA, 2018).

Feedstock and Refined Product Costs

An economical model—the Hofstrand model—was used to assess the levelized cost of fuel (LCOF) for ethanol on a per gallon basis. Representative 50- and 100-million-gallon-per-year (MMGPY) capacity ethanol plants constructed in Iowa in 2007 are modeled. Net production costs include feedstock (corn), natural gas, other variable costs, and fixed costs, as well as co-product revenue from DDGS. For plants of both sizes, all variable production costs are identical, although fixed costs differ by plant size. For corn ethanol, the cost for corn feedstock was \$1.34/gallon, natural gas was \$0.12/gallon, and non-fuel variable costs are \$0.22/gallon (Hofstrand, 2020). Fixed operating costs for the 50-MMGPY plant were \$0.43/gallon of capacity compared to \$0.21/gallon for the larger 100-MMGPY plant over a 15-year depreciation period. Co-product revenue for both plants is \$0.41/gallon over the same depreciation period. The resulting LCOF for the 50-MMGPY plant is \$1.72/gallon of ethanol and \$1.50/gallon for the 100-MMGPY plant (Hofstrand, 2020).

Key Policies

At the Federal level, the RFS is the primary policy driver of ethanol production and consumption. The RFS program sets targets for renewable fuels, including ethanol that must be blended with conventional transportation fuels. The current program includes an implied limit of volume of 15 billion gallons of conventional biofuel annually. Additionally, federally funded incentive programs, such as the Higher Blends Incentive Infrastructure Program and the Advanced Biofuel Production Grants and Loan Guarantee, provide financial assistance for the development of advanced biofuel plants and retail infrastructure. At the State level, GHG emission reduction policies, such as LCFS, provide market incentives for the production of lower carbon intensity ethanol. In California, ethanol fuel consumed within the State had an average carbon intensity of 78.28 gCO₂/MJ at the beginning of the LCFS in 2011; as of 2019, the average carbon intensity of ethanol fuel consumed decreased to 66.01 gCO₂/MJ (ICF, 2020, p. 1).²⁷

Challenges to Extending Adoption

Although the ethanol industry has significantly expanded over the past two decades, there are policy, infrastructure, and vehicle preference challenges to its continued growth. The implicit 15-billion-gallon annual RFS limit on ethanol has depressed industry investments to add capacity. Retail infrastructure, serving E15 and higher ethanol blends, will need to continue to grow. Lastly, the transition to electric and natural gas-fueled vehicles reduces demand for gasoline and ethanol.

Biodiesel

Technology Description

Biodiesel is a renewable fuel manufactured domestically from renewable oils, most notably vegetable oils, animal fats, or used cooking oil. While there are various technologies for producing biodiesel, the overall chemistry of the process is the same: vegetable oils (post-consumer or virgin oils) or animal fats are transformed into biodiesel and glycerin. The production process of biodiesel consists of three sub-processes: pretreatment (degumming and acid esterification), biodiesel production (transesterification), and refining (typically distillation). Pretreatment converts free fatty acids (FFA) to fatty acid methyl esters through the introduction of methanol in the presence of acid catalyst (Photaworn, et al., 2017). Transesterification converts triglycerides to biodiesel with the addition of short-chain alcohol molecules in the presence of a base catalyst, typically sodium methylate. During refining,

²⁷ The units of measure for carbon intensity used are grams (g) of carbon dioxide (CO₂) per megajoule (MJ).

unreacted feedstock, contaminants, and sterols are removed. Two refining techniques are most common: wet washing and dry washing (Atadashi, et al., 2011).

Renewable diesel is made from the same feedstocks used to produce biodiesel. However, with renewable diesel, esterification of the FFAs is not required prior to the reactor. Renewable diesel production utilizes a process called hydrotreating, which uses hydrogen to convert triglycerides and FFAs to fully saturated paraffinic hydrocarbons (Yoon, 2011).

Benefits

Biodiesel and renewable diesel are domestically produced, renewable, low-carbon alternative fuel options for the transportation sector. Life cycle analyses, conducted by Argonne National Laboratory, Purdue University, and USDA, found that substituting soy biodiesel for conventional petroleum diesel achieves a 66 percent to 76 percent reduction in GHG emissions (Chen, et al., 2018). Because biodiesel is produced domestically, it provides energy security by reducing the need for petroleum imports (EIA, 2019c).

National Market Size and Trends

Federal policies have played an important role in the development of domestic markets for biodiesel and renewable diesel. These include the enactment of the RFS as part of the Energy Policy Act of 2005 and, even more significantly, the second revision of the RFS (RFS2) as part of the Energy Independence and Security Act of 2007. The biodiesel tax credit and other Federal incentive programs have supported expansion as well. Biodiesel has grown substantially since 2001, when annual production was 9 million gallons (EIA, 2020b, table 10.4). In 2018, annual biodiesel production reached an all-time high of 1.86 billion gallons, and then decreased modestly to 1.7 billion gallons in 2019 (EIA, 2020b, table 10.4). DOE estimates that renewable diesel annual production capacity was 356 million gallons in 2019 (DOE, 2020a).

U.S. biodiesel consumption remained below 500 million gallons per year between 2001 and 2009. A sharp increase between 2010 and 2017 resulted in consumption surpassing 2 billion gallons in 2016. However, as of 2019 consumption has fallen to approximately 1.8 billion gallons (EIA, 2020b, table 10.4). The United States accounts for about 22 percent of global biodiesel consumption (EIA, 2019d).

Feedstock Market

The feedstock market for biodiesel is dominated by soybean oil, which comprised 57 percent of the biodiesel feedstocks consumed in 2019 (EIA, 2020g).²⁸

Regional Distinctions

Similar to corn ethanol plants, biodiesel plants are concentrated in the Midwest, close to soybean production: "more than half of the nation's biodiesel production capacity is in the Midwest (PADD 2)²⁹ region" (EIA, 2019e). Roughly 93 percent of the biodiesel produced in the United States is consumed domestically, with the remaining 7 percent being exported (EIA, 2020g).

Feedstock and Refined Product Costs

A representative 30-MMGPY capacity biodiesel plant built in Iowa in 2007 was used to model biodiesel production costs. The production costs include feedstock (soybean oil), natural gas, methanol, other variable costs, and fixed costs. For soybean oil feedstock, the 5-year average cost for biodiesel was \$2.38/gallon, natural gas was \$0.04/gallon, methanol was \$0.13/gallon, and other variable costs were \$0.25/gallon. Fixed operating costs were \$0.26/gallon of capacity over the depreciation period. The resulting LCOF for biodiesel production was \$3.06/gallon (Hofstrand, 2019). Soybean oil makes up more than 80 percent of variable operating costs for biodiesel, which means that changes in the market price of biodiesel generally reflect changes in soybean oil prices (Irwin, 2019).

²⁸ The remainder of this feedstock market is comprised of corn oil (14%), recycled feedstocks (11%), canola oil (10%), and animal fats (8%) (EIA, 2020g).

²⁹ PADD is the acronym for Petroleum Administration for Defense Districts.

Key Policies

The RFS is the primary driver of U.S. biodiesel production and consumption at the Federal level. The biodiesel mixture credit, commonly known as the blenders tax credit (BTC), which provides \$1/gallon for blending biodiesel or renewable diesel into the fuel pool has also had a strong impact on U.S. biodiesel growth (NREL, 2018b). Additional financial incentive programs include loans, loan guarantees, and project grants to support the development of biodiesel plants and retail infrastructure. The most significant State policy is the California LCFS followed by the Oregon Clean Fuels Program.

Challenges to Extending Adoption

Barriers to the expansion of biodiesel and renewable diesel are primarily related to infrastructure compatibility and end use. Many retail stations interested in selling blends above 5 percent (B05) will need to invest in refueling equipment upgrades and, in some cases, new storage tanks that are compatible with storing and dispensing higher biodiesel blends (DOE, 2020c). Progress is being made on the storage of B20 in existing infrastructure. For example, in August 2019, California was the last State to approve the storage of B20 in underground storage tanks (National Biodiesel Board, 2019). However, other restrictions remain for major infrastructure, such as pipelines due to concerns regarding biodiesel's incompatibility with jet fuel (CalEPA, 2018, p. 44).

PROFILES OF AGRICULTURAL FEEDSTOCKS

Agricultural feedstocks include purpose-grown crops for bioenergy (electricity and heat) and liquid biofuels production. The use of corn and soybean crops for ethanol and biodiesel is described above. This section focuses on the potential use of Miscanthus (*Miscanthus x giganteus*) and switchgrass (*Panicum virgatum*) as feedstocks for bioenergy and biofuels production. Both plants are perennial, warm-season, tall grasses that are technically well-suited as purpose-grown energy crops. Detailed descriptions of these feedstocks, along with forestry energy crops, are in chapter 8 of this report.

Agricultural Energy Crops: Switchgrass and Miscanthus

Description

Switchgrass is native to most of the United States, can be grown from seed, and is typically 5 to 6 feet tall. It has been used in the United States for more than 70 years as a hay and forage crop and, more recently, as an energy feedstock (USDA, 2019e). It is resistant to most pests and diseases. It is a fast-growing grass with a normal life span before replacement of approximately 10 years. However, unlike Miscanthus, which is sterile, switchgrass can be invasive.

Miscanthus is a sterile, hybrid grass native to subtropical Asia (USDA, 2019f). It is usually planted using rhizomes (roots) or plugs, has bamboo-like stems, and typically grows 12 to 15 feet tall. It has no native pests or diseases in the United States, is non-invasive, and has rapid growth rates over a typical 20-year life span. Species of Miscanthus have been used as a forage crop and for roof thatching for thousands of years. More recently, giant Miscanthus has been grown and used commercially in Europe for animal bedding and to generate heat and electricity (USDA, 2019f). Interest in the United States also has increased regarding its use as a feedstock for renewable power generation and for cellulosic ethanol production.

Benefits

Switchgrass and Miscanthus do not need to compete with other agricultural crops for land as both can be grown on poor and marginal lands. Both require little additional nutrient requirements and, once established, require minimal attention or maintenance. Both grasses can provide good soil-building characteristics, carbon sequestration, and wildlife cover (AGMRC, 2018a). Autumn harvesting of both grasses can be scheduled to fit with the scheduled harvesting of other crops. Both grasses also can be harvested with standard equipment, requiring only slight modification. Once harvested and baled, the grasses can be stored outside before use. Alternatively, both crops may be overwintered in the field and harvested in the spring.

Switchgrass can be grown throughout the United States; however, like Miscanthus, it is most productive in the wetter eastern half of the United States. Annual yields of switchgrass, depending on the type, can be 2 to 8 tons/acre. Switchgrass is tolerant of poor soils, flooding, and drought (AGMRC, 2018b). It has been demonstrated to be a valuable fiber source for manufactured composite "wood" products and fiber-plastic composite materials (AGMRC, 2018b). It also may be used to co-fire with coal in existing power plants to generate electricity, as a pelletized fuel for domestic use, or as a feedstock in bio-reactors that produce bio-based fuels or industrially important chemicals (AGMRC, 2018b).

Miscanthus yields (7 to 11 tons/acre/year) can be up to approximately six times higher than switchgrass yields (Khanna, et al., 2008, pp. 482–493). Miscanthus also has a high lignocellulose yield, which could position it as an important feedstock for cellulosic ethanol production in the future (USDA, 2019f).

National Market Size and Trends

Currently, there is little commercial production of switchgrass and Miscanthus in the United States. According to the latest USDA census, 978 acres and 6,246 tons of switchgrass were harvested in the United States in 2017. This was down from 3,082 acres and 11,795 tons in 2012 (USDA, 2019g). The decline appears to result from the completion of demonstration projects. Similarly, there is little commercial production of Miscanthus, with 5,400 acres and 41,557 tons harvested in 2017 (USDA, 2019h).

Regional Distinctions

There is currently little switchgrass or Miscanthus grown for energy crop purposes in the United States. The Midwest is considered the prime area for future switchgrass cultivation, while areas with more than 30 inches of annual rain (such as the Pacific Northwest and the Eastern United States) are the most suitable for future Miscanthus cultivation (yields increase with increased annual precipitation) (USDA, 2019f).

Costs

Because there is little commercial production of switchgrass or Miscanthus in the United States, assessing the costs of production is primarily based on demonstration projects and estimates. For switchgrass, production costs are estimated to be in the range of \$55 to \$97/dry ton (in 2020 dollars) before transportation and processing (Biomass Magazine, 2019; Duffy, 2008, p. 4; Walling, 2005, p. 25). Similarly, Miscanthus production costs are estimated to be in the range of \$42 to \$90/dry ton (in 2020 dollars) before transportation and processing (Hoque, et al., 2014, pp. 4–8; Khanna, et al., 2008, pp. 482–493). While Miscanthus has higher start-up costs (related to needing to use rhizomes or plugs for planting), its yields are generally much higher than switchgrass yields. As a result, Miscanthus will likely have lower break-even costs than switchgrass in most cases.

Key Policies

At the Federal level, the most influential current policy that promotes the use of biomass for electricity is the production tax credit. This credit was extended in December 2019 and applies to qualifying bioenergy projects that commence construction or meet safe harbor investment requirements by the end of 2020. At the State level, RPS and CES policies promote the use of biomass and bioenergy crops, although there are distinctions at the State level on how to treat carbon emissions from biomass use and whether biomass power production is considered to be carbon neutral.

Challenges to Extending Adoption

Without a significant change in the costs of existing energy alternatives, it will likely require additional government incentives (e.g., tax credits, cost sharing, loan guarantees, carbon credits) to make switchgrass and Miscanthus competitive fuel sources (Biomass Magazine, 2019; Khanna, et al., 2008, pp. 482–493). Development of more efficient thermochemical or enzymatic conversion technologies for biofuels and chemicals production could promote increased markets for both grasses as feedstocks for cellulosic ethanol and cellulosic diesel.

PROFILES OF FORESTRY FEEDSTOCKS

Forestry has a number of potential woody energy crops that could serve as purpose-grown feedstocks for bioenergy and biofuels production. These are distinct from the biomass byproducts of typical forestry

operations that are often used for energy purposes (e.g., tree trimmings, forest thinnings, logging and sawmill residues, land clearance). This section focuses on two commonly discussed potential forestry energy crops—hybrid poplar and willow.

Forestry Energy Crops: Poplar and Willow

Description

Poplar (*Populus spp.*) trees are one of the fastest growing temperate trees. There are 25 to 35 species of poplar, a deciduous flowering hardwood tree in the same family as willow, aspen, and cottonwood. Poplar hybrids have been bred to achieve growth rates of 5 to 10 feet/year (USDA, 2019i). Poplar trees have been used for pulp and paper, lumber, windbreaks, environmental improvements (e.g., soil carbon sequestration, sediment reduction, phytoremediation), and, more recently, for biofuel production (USDA, 2019i). When grown as an energy crop, to promote maximum yield, hybrid poplar is coppiced to encourage the growth of multiple stems that can be harvested every 3 to 4 years over a 20-year life cycle (Townsend, et al., 2018, p. 7).

Willow (*Salix spp.*) is another fast-growing, temperate hardwood tree. There are more than 200 willow species in the same family as poplar. Species range from small to large deciduous shrubs and trees.

Benefits

With sufficient rainwater, both hybrid poplar and willow trees can be grown on poor and marginal lands, including idle, retired, or unproductive cropland (Townsend, et al., 2018, p. 7). They require little to no additional nutrient input, can be harvested at any time of the year in short rotation (typically 3 to 4 years for willow and 3 to 13 years for poplar), and can be re-harvested multiple times before replanting is required. Harvesting and storage (as chips or logs) are similar to other small trees and use conventional forage harvesting equipment.

In addition to their benefits as a potential source of bioenergy, both hybrid poplar and willow can provide environmental benefits such as soil carbon sequestration, sediment reduction, and phytoremediation. They also can be used as windbreaks to protect other crops and animals (Townsend, et al., 2018, p. 8). Poplar and willow have been shown to increase the abundance of small mammals and native songbirds. Willow produces an abundance of flowers in early spring before most other plants bloom, providing a valuable early food source for bees and other pollinators (Townsend, et al., 2018, p. 11).

Poplar's chemical composition is high in cellulose and low in lignin. This provides the high levels of carbohydrates needed to produce energy for liquid fuels (high cellulose) with relative ease of extraction (low lignin) (USDA, 2019i). Willow has a low (8 percent to 17 percent) silica ash content, making it a clean fuel for combustion (CEE, 2007, p. 44).

Yields of hybrid poplar are typically 1.25 to 8.6 dry tons/acre/year; those for willow are typically 1.6 to 6.3 dry tons/acre/year (Volk, et al., 2018, pp. 735–751).

National Market Size and Trends

According to USDA, 639 acres of hybrid poplar were in production in 2014 (the latest data available for poplar as it is now included with other biomass totals) (USDA, 2019j).³⁰ Of this total, 133 acres were harvested, and 18,951 tons of wood were produced (USDA, 2019j). This was down from 734 acres harvested in 2009 (USDA, 2019j). This reduction appears to be the result of the completion of demonstration projects.

There are currently no comprehensive data on the number of acres of willow grown for biofuel production. It is estimated that approximately 1,200 acres of shrub willow were grown for commercial energy in 2018 (Townsend, et al., 2018, p. 15; Volk, et al., 2018, p. 2).

³⁰ The amount of hybrid poplar in production in 2014 varied from 211 acres in August to 2,554 acres in November (DOE, 2016b, p. 28).

Regional Distinctions

Little data are available to show the differences in hybrid poplar production costs or yields in different regions of the country. Poplar can grow throughout the United States and tends to grow best in areas with full sun and high moisture (USDA, 2019i). Given the current varieties of poplar, field trials and computer mapping indicate that the Eastern half of the United States and the Northwest will be the most productive areas for poplar forestry.

Similarly, there are little data to show the differences in willow production costs or yields in different regions of the country. For current varieties of willow, field trials and computer mapping indicate that the Eastern half of the United States and the Pacific Northwest will be the most productive areas for cultivation due to their water requirements for optimal growth (Townsend, et al., 2018, p. 8; Volk, et al., 2018, p. 9; Volk, et al., 2016, p. 8).

Costs

Because there is currently little commercial production of hybrid poplar and willow in the United States, assessing the costs of production is primarily based on demonstration projects and estimates by experts. A study in Minnesota in 2007 indicated that the production cost for hybrid poplar was \$5.33/MMBtu (in 2020 dollars) (CEE, 2007, p. 39, figure III-14). With transportation, storage, and processing, the estimated hybrid poplar cost at the user facility (e.g., biomass power production or biofuel refinery) was estimated to be \$10.05/MMBtu (in 2020 dollars) (CEE, 2007, p. 39, figure III-14). For willow, a study for the Illinois market indicated a production cost of \$6.22/MMBtu (in 2020 dollars) and a user's facility delivered cost, with transportation, of \$7.74/MMBtu (in 2020 dollars) (Ssegane, et al., 2016, p. 785).

Key Policies

As with agricultural energy crops, at the Federal level, the most influential current policy that promotes the use of forestry energy crops for biomass power generation is the production tax credit. Recent EPA rulemaking on the carbon neutrality of certain forms of biomass also may support feedstock industries (Biomass Magazine, 2020). At the State level, RPS and CES policies that promote the use of biomass for electricity production can benefit all eligible feedstocks, including forestry crops.

Challenges to Extending Adoption

Without a significant change in the costs of existing energy alternatives, it will likely require additional government incentives (e.g., tax credits, cost sharing, loan guarantees, carbon credits) to make hybrid poplar and willow competitive fuel sources.

Wood Pellets and Wood Chips

Wood chips and wood pellets are derived from wood residues obtained directly from the forest, or indirectly from wood manufacturing, processing factories, or urban waste. Detailed descriptions of these feedstocks are in chapter 9 of this report.

Description

Wood chips are small- to medium-sized pieces of residual wood formed by cutting or chipping larger pieces of wood, wood residues, and construction debris into pieces of somewhat uniform thickness and maximum overall dimensions. Virtually all wood chips used for energy are directly combusted to produce heat and electricity; however, they also can be converted to liquid and gaseous fuels or fuel precursors through chemical, thermal, and/or biological processes such as gasification, pyrolysis, hydrothermal liquefaction, catalytic hydrothermal gasification, and hydrolysis. The predominant uses of wood chips in the United States are for paper, wood products, and wood pellets. Approximately half of the wood chips not used for paper production are used for pellets (Edwards, 2019).

Wood pellets are a type of densified biomass fuel made from small, dried wood particles or sawdust that are compressed into a smaller volume of a specific size, shape, moisture, density, and energy content. Feedstocks for wood pellets may consist of wood chips or residues captured from other wood product manufacturing processes (e.g., saw dust from lumber mills, forest residuals, and from logs). In residential applications, wood pellets are used for heating in pellet stoves or furnaces. Utilities and

industrial facilities also use pellets in solid-fuel boilers to produce steam for heating, process steam, or generating electricity (Portz, 2018).

Benefits

Energy produced from trees harvested from sustainably managed forests, forest residues, or residues from forest product manufacturing (which make up the primary resource for wood chips and pellets in the United States) reduces carbon emissions relative to that energy being generated using fossil fuels. This is because the carbon emitted when combusting wood is recaptured from the atmosphere with the growth of the next rotation of trees. Additionally, when the feedstock is dead trees and forest residues, energy is recovered from emissions that would have occurred otherwise due to natural decomposition (Shelly, n.d.).

Increased production of wood chips and pellets, when forests are sustainably managed, also may promote forest health and decrease wildfire danger (Stephens, et al., 2018). Wood pellets and wood chips have a substantial employment impact, with the woody biomass fuels industry providing 33,000 jobs and the U.S. biomass electrical power industry providing 13,000 jobs (NASEO, 2020, pp. 32 and 81).

National Market Size and Trends

In 2018, about 2 percent of total U.S. annual energy consumption was from wood and wood waste—bark, sawdust, wood chips, wood scrap, and paper mill residues. Of the 2,356 trillion British thermal units (BTU) of wood and wood waste consumed in 2018, approximately 65 percent was used by the industrial sector, 22 percent by the residential sector, 9 percent for electric power, and 4 percent by the commercial sector (EIA, 2019f). Approximately two-thirds of the wood pellets produced in the United States are exported to European markets (INL, 2017, p. 16). In recent years, the global market for utility-grade pellets has grown about 10 percent per year, and this trend is expected to continue in the near term as a result of the European Union's (EU) Renewable Energy Directive (Canadian Biomass Magazine, 2017).

Regional Distinctions

The geographic distribution of wood chip and pellet production coincides with forest production. Small- and medium-scale plants, producing mostly wood pellets for the domestic heating market, are concentrated in the Northeast and the Pacific Northwest.

Large-scale, export-oriented wood pellet producers are overwhelmingly located in the Southeast. The proximity to East Coast ports offers these plants low-cost access to European markets. The Southeast also has established plantation forests; a favorable climate for year-round tree growth; and working-forest management expertise, labor, and infrastructure from its history of supplying the wood products, pulp and paper, and furniture industries (INL, 2017, pp. 1, 4).

Costs

The material costs of resources used for wood chips and pellets vary based on factors such as the size and type of wood, season, year, and location. Location-specific factors, such as geography and climate, as well as site-specific considerations, such as on-site maneuverability and distance to market, contribute to the lower cost of residual wood in the Southeast compared to forest regions in New England and the Pacific Northwest. In 2018, softwood sawmill residual wood chips cost \$75/dry ton in the Southeast on a delivered basis, while prices in the Pacific Northwest were typically around \$100/dry ton (Greene, 2018).

Transportation costs are an important operating cost factor. The per mile transportation cost for wood chips is estimated at \$0.046/dry ton mile for a loaded truck and \$0.028/dry ton mile for an empty truck (DOE, 2016b, p. 227).

Using an average capital cost of approximately \$1.2 to \$2 million per desired short ton per hour production level, a relatively large industrial- or utility-grade green pellet plant with 500,000 metric tons/year (550,000 short tons/year) of capacity costs approximately \$75 million to build, while a smaller, 100,000-metric ton/year (110,000-short ton/year) pellet plant would cost approximately \$27 million (Vecoplan Midwest, 2016).

Key Policies

Domestically, several States have programs and/or policies that incentivize the demand for residential wood pellets. Internationally, increasing demand for utility-grade wood pellets has been spurred by the EU's Renewable Energy Directive. This directive requires that the EU meets 32 percent of its total energy needs with renewables by 2030, and it sets individual targets for each country in the EU (European Commission, 2020). This mandate is likely to increase European demand for U.S. wood chips and pellets.

Challenges to Extending Adoption

Availability and cost represent the greatest challenges to extending the use of wood chips and wood pellets. In some regions, it is difficult to obtain enough feedstock near large processing plants to take advantage of economies of scale in harvesting, transporting, and storing woody biomass. The low-energy density of woody biomass compared to fossil fuels also is a challenge to expanding the wood chip and wood pellet markets (Shelly, n.d.).

REFERENCES

- AGMRC. 2018a. Miscanthus Profile. Agricultural Marketing Resource Center. <https://www.agmrc.org/commodities-products/biomass/miscanthus-profile> [accessed June 2020].
- AGMRC. 2018b. Switchgrass. Agricultural Marketing Resource Center. <https://www.agmrc.org/commodities-products/biomass/switchgrass> [accessed June 2020].
- AGMRC. n.d. U.S. Corn Usage for Ethanol, Dry Mill Ethanol Co-Products Production, and Ethanol Yields Update. Agricultural Marketing Resource Center. <https://www.agmrc.org/renewable-energy/renewable-energy-climate-change-report/renewable-energy-climate-change-report/february-2018-report/us-corn-usage-for-ethanol-dry-mill-ethanol-co-products-production-and-ethanol-yields-update> [accessed June 2020].
- ANL. 2008. *Update of Distillers Grains Displacement Ratios for Corn Ethanol Life-Cycle Analysis*. Argonne National Laboratory. <https://greet.es.anl.gov/publication-3bi0z09m> [accessed June 2020].
- Atadashi, et al. 2011. Refining Technologies for the Purification of Crude Biodiesel. *Applied Energy*: 88 (12), 4239-4251. Atadashi, I., Aroua, M., Abdul Aziz, A., & Sulaiman, N. <https://www.sciencedirect.com/science/article/abs/pii/S0306261911003242?via%3Dihub> [accessed August 2019].
- AWEA. 2020. *U.S. Wind Industry Quarterly Market Report: Fourth Quarter 2019*. American Wind Energy Association. <https://www.awea.org/resources/publications-and-reports/market-reports/2019-u-s-wind-industry-market-reports> [accessed June 2020]. Note: AWEA merged into the American Clean Power Association (ACP) on January 1, 2021.
- Biomass Magazine. 2019. Switchgrass Pioneers. <http://biomassmagazine.com/articles/1255/switchgrass-pioneers> [accessed June 2020].
- Biomass Magazine. 2020. Senate Hearing Addresses Wood Stoves, RFS and Biomass Neutrality. <http://biomassmagazine.com/articles/17079/senate-hearing-addresses-wood-stoves-rfs-and-biomass-neutrality> [accessed June 2020].
- CalEPA, 2018. *CalEPA Fuels Guidance Document*. California Environmental Protection Agency. https://ww2.arb.ca.gov/sites/default/files/2018-10/CalEPA_Fuels_Guidance_Document_10-2-18.pdf [accessed June 2020].
- Canadian Biomass Magazine. 2017. Global Pellet Market Outlook in 2017. <https://www.canadianbiomassmagazine.ca/growing-demand-for-pellets-6074/> [accessed December 2018].
- CEE. 2007. *Identifying Effective Biomass Strategies: Quantifying Minnesota's Resources and Evaluating Future Opportunities*. The Center for Energy and Environment. <https://www.mncee.org/getattachment/Resources/Resource-Center/Technical-Reports/Identifying-Effective-Biomass-Strategies-Quantify/Identifying-Effective-Biomass-Strategies.pdf.aspx> [accessed June 2020].
- Chen, et al. 2018. Life Cycle Energy and Greenhouse Gas Emission Effects of Biodiesel in the United States with Induced Land Use Change Impacts. *Bioresource Technology*, 251, 249-258. Chen, R., Qin, Z., Han, J., Wang, M., Taheripour, F., Tyner, W, O'Connor, D, Duffield, J. <https://www.sciencedirect.com/science/article/pii/S0960852417321648?via%3Dihub> [accessed August 2019].
- Clifford, C. 2018. *How Corn is Processed to Make Ethanol*. College of Earth and Mineral Sciences, Pennsylvania State University. <https://www.e-education.psu.edu/egee439/node/673> [accessed June 2020].
- DOE. 2016a. *Strategic Plan for a Thriving and Sustainable Bioeconomy*. U.S. Department of Energy. https://www.energy.gov/sites/prod/files/2017/09/f36/beto_strategic_plan_december_2016.pdf [accessed June 2020].
- DOE. 2016b. *2016 Billion-Ton Report: Advancing Domestic Resources for a Thriving Bioeconomy*. U.S. Department of Energy. <http://energy.gov/eere/bioenergy/2016-billion-ton-report> [accessed January 2020].
- DOE. 2018. *Ethanol Basics*. U.S. Department of Energy. https://afdc.energy.gov/files/u/publication/ethanol_basics.pdf [accessed June 2020].
- DOE. 2019a. Wind Energy's Economic Impacts to Communities. U.S. Department of Energy. <https://windexchange.energy.gov/projects/economic-impacts> [accessed June 2020].
- DOE. 2019b. *2018 Distributed Wind Market Report*. U.S. Department of Energy. <https://www.energy.gov/sites/prod/files/2019/08/f65/2018%20Distributed%20Wind%20Market%20Report.pdf> [accessed June 2020].
- DOE. 2019c. *2018 Wind Technologies Market Report*. U.S. Department of Energy. <https://www.energy.gov/sites/prod/files/2019/08/f65/2018%20Wind%20Technologies%20Market%20Report%20FINAL.pdf> [accessed June 2020].
- DOE. 2020a. Renewable Hydrocarbon Biofuels. U.S. Department of Energy. https://afdc.energy.gov/fuels/emerging_hydrocarbon.html [accessed June 2020].

- DOE. 2020b. *2018 Renewable Energy Data Book*. U.S. Department of Energy. <https://www.nrel.gov/docs/fy20osti/75284.pdf> [accessed June 2020].
- DOE. 2020c. *Biodiesel Equipment Options*. U.S. Department of Energy. https://afdc.energy.gov/fuels/biodiesel equip_options.html [accessed May 2020].
- Duffy, M. 2008. *Estimated Costs for Production, Storage and Transportation of Switchgrass*. *Ag Decision Maker*. Iowa State University. <https://www.extension.iastate.edu/agdm/crops/pdf/a1-22.pdf> [accessed June 2020].
- Edwards, D. 2019. Interview with Dick Edwards, Peterson Inc. by J. Lukas, ICF. February 2019.
- EIA. 2016. *Capital Cost Estimates for Utility Scale Electricity Generating Plants*. U.S. Energy Information Administration, DOE. https://www.eia.gov/analysis/studies/powerplants/capitalcost/pdf/capcost_assumption.pdf [accessed June 2020].
- EIA. 2017. *U.S. Fuel Ethanol Production Continues to Grow in 2017*. U.S. Energy Information Administration, DOE. <https://www.eia.gov/todayinenergy/detail.php?id=32152> [accessed June 2020].
- EIA. 2018. *U.S. Fuel Ethanol Plant Production Capacity*. U.S. Energy Information Administration, DOE. <https://www.eia.gov/petroleum/ethanolcapacity/> [accessed June 2020].
- EIA. 2019a. *Existing Net Summer Capacity of Other Renewable Sources by Producer Type, 2008 through 2018 (Megawatts)*. U.S. Energy Information Administration, DOE. https://www.eia.gov/electricity/annual/html/epa_04_02_b.html [accessed June 2020].
- EIA. 2019b. *EIA Expects Stable U.S. Biofuels Production, Consumption, and Trade through 2020*. Energy Information Administration, DOE. <https://www.eia.gov/todayinenergy/detail.php?id=38532#:~:text=EIA%20expects%20stable%20U.S.%20biofuels%20production%2C%20consumption%2C%20and%20trade%20through%202020,-Source%3A%20U.S.%20Energy&text=EIA%20expects%20that%20U.S.%20fuel,million%20b%2Fd%20in%202020.> [accessed June 2020].
- EIA. 2019c. *Oil and Petroleum Products Explained: Oil Imports and Exports*. Energy Information Administration, DOE. https://www.eia.gov/energyexplained/index.php?page=oil_imports [accessed August 2019].
- EIA. 2019d. *Biofuels Explained: Use of Biomass-Based Diesel Fuel*. Energy Information Administration, DOE. <https://www.eia.gov/energyexplained/biofuels/use-of-biodiesel.php> [accessed August 2019].
- EIA. 2019e. *EIA Releases Plant-Level U.S. Biodiesel Production Capacity Data*. Energy Information Administration, DOE. <https://www.eia.gov/todayinenergy/detail.php?id=41314> [accessed June 2020].
- EIA. 2019f. *Biomass Explained: Wood and Wood Waste*. U.S. Energy Information Administration, DOE. <https://www.eia.gov/energyexplained/biomass/wood-and-wood-waste.php> [accessed July 2019].
- EIA. 2020a. *Electric Power Monthly, Data for January 2020*. U.S. Energy Information Administration, DOE. <https://www.eia.gov/electricity/monthly/> [accessed April 2020].
- EIA. 2020b. *Monthly Energy Review, May 2020*. U.S. Energy Information Administration, DOE. <https://www.eia.gov/totalenergy/data/monthly/#renewable> [accessed June 2020].
- EIA. 2020c. *Electricity Data Browser, Net Generation for Biomass, Annual*. U.S. Energy Information Administration, DOE. <https://www.eia.gov/electricity/data/browser/#/topic/0?agg=1,0,2&fuel=0008&geo=vvvvvvvvvv&sec=o3g&freq=A&start=2014&end=2018&ctype=linechart<ype=pin&rtype=s&pin=rse=0&matype=1> [accessed February 2020].
- EIA. 2020d. *Short-Term Energy Outlook, April 2020*. U.S. Energy Information Administration, DOE. https://www.eia.gov/outlooks/steo/pdf/steo_full.pdf [accessed April 2020].
- EIA. 2020e. *Wind Explained: Electricity Generation From Wind*. U.S. Energy Information Administration, DOE. https://www.eia.gov/energyexplained/index.php?page=wind_electricity_generation [accessed June 2020].
- EIA. 2020f. *Cost and Performance Characteristics of New Generating Technologies, Annual Energy Outlook 2020*. U.S. Energy Information Administration, DOE. https://www.eia.gov/outlooks/aeo/assumptions/pdf/table_8.2.pdf [accessed June 2020].
- EIA. 2020g. *Biofuels Explained: Biomass-Based Diesel Fuels*. Energy Information Administration, DOE. <https://www.eia.gov/energyexplained/biofuels/biodiesel.php> [accessed June 2020].
- EPA. 2018. *Biofuels and the Environment: The Second Triennial Report to Congress*. U.S. Environmental Protection Agency. https://cfpub.epa.gov/si/si_public_record_report.cfm?Lab=IO&dirEntryId=341491 [accessed August 2020].
- EPA. 2020. *AgSTAR: Livestock Anaerobic Digester Database*. U.S. Environmental Protection Agency. <https://www.epa.gov/agstar/livestock-anaerobic-digester-database> [accessed June 2020].
- European Commission. 2020. *Renewable Energy Directive*. https://ec.europa.eu/energy/topics/renewable-energy/renewable-energy-directive/overview_en#sustainable-biofuels [accessed May 2020].

- FTI Consulting. 2018. *The Biodiesel Industry: Impacts on the Economy, Environment and Energy Security*. <https://www.fticonsulting.com/~media/Files/us-files/insights/reports/biodiesel-industry-impacts-economy-environment-energy-security.pdf> [accessed June 2020].
- Greene, J. 2018. Chip & Pulpwood Price Trends in the US South & PNW. Forest2Market. <https://blog.forest2market.com/chip-pulpwood-price-trends-in-the-us-south-pnw> [accessed December 2018].
- Hofstrand, D. 2019. Biodiesel Profitability. Iowa State University. <https://www.extension.iastate.edu/agdm/energy/html/d1-15.html> [accessed August 2019].
- Hofstrand, D. 2020. Ethanol Profitability. Iowa State University. <https://www.extension.iastate.edu/agdm/energy/html/d1-10.html> [accessed February 2020].
- Hoque, et al. 2014. *Estimated Cost of Establishment and Production of Miscanthus in Iowa*. Iowa State University. Ag Decision Maker, A1–28. Hoque, M., Artz, G., & Hart, C. <https://www.extension.iastate.edu/agdm/crops/pdf/a1-28.pdf> [accessed June 2020].
- ICF. 2020. *California Low Carbon Fuel Standard: Incentivizing Greenhouse Gas Mitigation in the Ethanol Industry*. <https://www.usda.gov/sites/default/files/documents/ethanol-mitigation-options-2020>
- INL. 2017. *U.S. Pellet Industry Overview*. Idaho National Laboratory. https://inldigitalibrary.inl.gov/sites/sti/sti/Sort_1078.pdf [accessed May 2020].
- IRS. 2019. *Instructions for Form 8835: Renewable Electricity, Refined Coal, and Indian Coal Production Credit*. Internal Revenue Service. <https://www.irs.gov/pub/irs-pdf/i8835.pdf> [accessed June 2020].
- Irwin, S. 2019. Biodiesel Production Profitability in 2018: Did Headwinds or Tailwinds Dominate? *Farmdoc Daily*, 9(54). <https://farmdocdaily.illinois.edu/2019/03/biodiesel-production-profitability-in-2018-did-headwinds-or-tailwinds-dominate.html> [accessed June 2020].
- Khanna, et al. 2008. Costs of Producing Miscanthus and Switchgrass for Bioenergy in Illinois. *Biomass and Bioenergy*, Volume 32, Issue 6, 482–493. Khanna, M., Dhungana, B., & Clifton-Brown, J. <https://www.sciencedirect.com/science/article/pii/S096195340700205X> [accessed June 2020].
- Lazard. 2017. *Lazard's Levelized Cost of Energy Analysis—Version 11.0*. <https://www.lazard.com/media/450337/lazard-levelized-cost-of-energy-version-110.pdf> [accessed June 2020].
- Lazard. 2019. *Lazard's Levelized Cost of Energy Analysis—Version 13.0*. <https://www.lazard.com/media/451086/lazards-levelized-cost-of-energy-version-130-vf.pdf> [accessed June 2020].
- LBL. 2019. *Tracking the Sun: Pricing and Design Trends for Distributed Photovoltaic Systems in the United States, 2019 Edition*. Ernest Orlando Lawrence Berkeley National Laboratory. https://emp.lbl.gov/sites/default/files/tracking_the_sun_2019_report.pdf [accessed June 2020].
- NARA. 2020. Rural Energy Savings Program, as published in the *Federal Register*, Vol. 85, No. 64, April 2, 2020. National Archives and Records Administration. <https://www.govinfo.gov/content/pkg/FR-2020-04-02/pdf/2020-06215.pdf> [accessed June 2020].
- NASEO. 2020. *2020 U.S. Energy & Employment Report*. National Association of State Energy Officials and Energy Futures Initiative. <https://static1.squarespace.com/static/5a98cf80ec4eb7c5cd928c61/t/5ee78423c6fcc20e01b83896/1592230956175/USEER+2020+0615.pdf> [accessed June 2020].
- National Biodiesel Board. 2019. California Approves B20 Biodiesel in Underground Storage Tanks. <https://www.biodiesel.org/news-resources/biodiesel-news/2019/08/25/California-Approves-B20-Biodiesel-in-Underground-Storage-Tanks> [accessed June 2020].
- NCCETC. 2017. *Balancing Agricultural Productivity With Ground-Based Solar Photovoltaic (PV) Development*. NC Clean Energy Technology Center. <https://nccleantech.ncsu.edu/wp-content/uploads/2018/10/Balancing-Ag-and-Solar-final-version-update.pdf> [accessed June 2020].
- NIBS. 2016. *Whole Building Design Guide, Biomass for Electricity Generation*. National Institute of Building Sciences. <https://www.wbdg.org/resources/biomass-electricity-generation> [accessed June 2020].
- NREL. 2013. *Land-Use Requirements for Solar Power Plants in the United States*. National Renewable Energy Laboratory. <https://www.nrel.gov/docs/fy13osti/56290.pdf> [accessed April 2020].
- NREL. 2016. *Assessing the Future of Distributed Wind: Opportunities for Behind-the-Meter Projects*. National Renewable Energy Laboratory. <https://www.nrel.gov/docs/fy17osti/67337.pdf> [accessed June 2020].
- NREL. 2018a. *U.S. Solar Photovoltaic System Cost Benchmark: Q1 2018*. National Renewable Energy Laboratory. <https://www.nrel.gov/docs/fy19osti/72399.pdf> [accessed June 2020].
- NREL. 2018b. *2016 Bioenergy Industry Status*. National Renewable Energy Laboratory. https://afdc.energy.gov/files/u/publication/2016_bioenergy_status_rpt.pdf [accessed June 2020].

- NREL. 2019a. Annual Technology Baseline: Electricity, Biopower. National Renewable Energy Laboratory. <https://atb.nrel.gov/electricity/2019/index.html?t=cb> [accessed June 2020].
- NREL. 2019b. *Beneath Solar Panels, the Seeds of Opportunity Sprout*. National Renewable Energy Laboratory. <https://www.nrel.gov/news/features/2019/beneath-solar-panels-the-seeds-of-opportunity-sprout.html> [accessed June 2020].
- NREL. 2019c. *Q4 2018/Q1 2019 Solar Industry Update*. National Renewable Energy Laboratory. <https://www.nrel.gov/docs/fy19osti/73992.pdf> [accessed June 2020].
- NREL. 2020. Land Use by System Technology. National Renewable Energy Laboratory. <https://www.nrel.gov/analysis/tech-size.html> [accessed June 2020].
- Photaworn, et al. 2017. Process Development of Two-Step Esterification Plus Catalyst Solution Recycling on Waste Vegetable Oil Possessing High Free Fatty Acid. (M. O. Coppens, Ed.) *Chemical Engineering and Processing: Process Intensification*, 118, 1-8. Photaworn, S., Tongurai, C., & Kungsanunt, S. <https://www.sciencedirect.com/journal/chemical-engineering-and-processing-process-intensification/vol/118/suppl/C> [accessed August 2019].
- Portz, T. 2018. Interview with T. Portz, Executive Director of PFI, by J. Lukas, ICF. December 2018.
- RFA. 2019. *2019 Ethanol Industry Outlook*. Renewable Fuels Association. <https://ethanolrfa.org/wp-content/uploads/2019/02/RFA2019Outlook.pdf> [accessed June 2020].
- RFA. 2020. Rural Economy: Ethanol Renewing the Heartland. Renewable Fuels Association. <https://ethanolrfa.org/rural-economy/> [accessed August 2020].
- Rosenfeld, et al. 2018. *A Life-Cycle Analysis of the Greenhouse Gas Emissions from Corn-Based Ethanol*. J. Rosenfeld, J., Lewandrowski, J., Hendrickson, T., Jaglo, K., Moffroid, K., & Pape, D. https://www.usda.gov/oce/climate_change/mitigation_technologies/LCA_of_Corn_Ethanol_2018_Report.pdf [accessed June 2020].
- Shelly, J. n.d. Woody Biomass Factsheet – WB1: Woody Biomass: What is it – What Do We Do With It? <https://www.pelletheat.org/assets/docs/industry-data/infoguides43284.pdf> [accessed May 2020].
- Ssegane, et al. 2016. The Economics of Growing Shrub Willow as a Bioenergy Buffer on Agricultural Fields: A Case Study in the Midwest Corn Belt. *Biofuels, Bioproducts and Biorefining*, Volume 10, Issue 6, 776–789. Ssegane, H., Zumpf, C., Negri, M., Campbell, P., Heavey, J., & Volk, T. <https://onlinelibrary.wiley.com/doi/pdf/10.1002/bbb.1679> [accessed June 2020].
- Stephens, et al. 2018. Drought, Tree Mortality, and Wildfire in Forests Adapted to Frequent Fire. *Bioscience*, Volume 68, Issue 2. Stephens, S., Collins, B., Fettig, C., Finney, M., Hoffman, C., Knapp, E., North, M., Safford, H., & Wayman, B. <https://academic.oup.com/bioscience/article/68/2/77/4797261> [accessed June 2020].
- Townsend, et al. 2018. *EM115E A Roadmap for Poplar and Willow to Provide Environmental Services and to Build the Bioeconomy*. Washington State University Extension. Townsend, P., Haider, N., Boby, L., Heavey, J., Miller, T. A., Volk, T. <https://research.wsulibs.wsu.edu/xmlui/handle/2376/13222> [accessed June 2020].
- USDA. 1999. *Crop Production*. U.S. Department of Agriculture. <https://downloads.usda.library.cornell.edu/usda-esmis/files/tm70mv177/fn106z825/9c67wn55n/CropProd-07-12-1999.pdf> [accessed June 2020].
- USDA. 2014. *Assessment of the National Prospects for Electricity Generation from Biomass*. U.S. Department of Agriculture. https://www.usda.gov/oce/reports/energy/USbiopower_04_2014.pdf [accessed June 2020].
- USDA. 2017. *Wind Energy Land Distribution in the United States of America*. U.S. Department of Agriculture. https://www.usda.gov/oce/energy/files/FINAL-Wind_Energy_Land_Distribution_in_the_United_States_of_America_7282017.pdf [accessed June 2020].
- USDA. 2018a. Feedgrains Sector at a Glance. U.S. Department of Agriculture. <https://www.ers.usda.gov/topics/crops/corn-and-other-feedgrains/feedgrains-sector-at-a-glance/> [accessed June 2020].
- USDA. 2018b. Quick Stats. U.S. Department of Agriculture. https://www.nass.usda.gov/Statistics_by_Subject/result.php?284568C0-F806-30AF-81C5-3DD8C2AB0298§or=CROPS&group=FIELD%20CROPS&comm=CORN [accessed May 2019].
- USDA. 2019a. U.S. Bioenergy Statistics. U.S. Department of Agriculture. <https://www.ers.usda.gov/data-products/us-bioenergy-statistics/> [accessed June 2020].
- USDA. 2019b. *USDA Forest Service 2020 Wood Innovation Grant, Region 5 Informational Webinar*. U.S. Department of Agriculture. <https://ucanr.edu/sites/WoodyBiomass/files/315811.pdf> [accessed June 2020].
- USDA. 2019c. *Crop Production 2018 Summary*. U.S. Department of Agriculture. https://www.nass.usda.gov/Publications/Todays_Reports/reports/cropan19.pdf [accessed June 2020].
- USDA. 2019d. Acreage. U.S. Department of Agriculture. https://www.nass.usda.gov/Publications/Todays_Reports/reports/acrg0619.pdf [accessed June 2020].

- USDA. 2019e. Switchgrass (*Panicum virgatum*) for Biofuel Production. U.S. Department of Agriculture. <https://farm-energy.extension.org/switchgrass-panicum-virgatum-for-biofuel-production/> [accessed June 2020].
- USDA. 2019f. Miscanthus (*Miscanthus x giganteus*) for Biofuel Production. U.S. Department of Agriculture. <https://farm-energy.extension.org/miscanthus-miscanthus-x-giganteus-for-biofuel-production/> [accessed June 2020].
- USDA. 2019g. Quick Stats, Switchgrass. U.S. Department of Agriculture. https://quickstats.nass.usda.gov/13C6E1A4-EAFA-382A-A861-66BE98A68CEF?long_desc__LIKE=switchgrass [accessed June 2020].
- USDA. 2019h. Quick Stats, Miscanthus. U.S. Department of Agriculture. https://quickstats.nass.usda.gov/13C6E1A4-EAFA-382A-A861-66BE98A68CEF?long_desc__LIKE=miscanthus [accessed June 2020].
- USDA, 2019i. Poplar (*Populus* spp.) Trees for Biofuel Production. U.S. Department of Agriculture. <https://farm-energy.extension.org/poplar-populus-spp-trees-for-biofuel-production/> [accessed June 2020].
- USDA. 2019j. Quick Stats. U.S. Department of Agriculture. <https://quickstats.nass.usda.gov/results/70819994-86C1-3C64-96EF-2965BD92C9C6> [accessed June 2020].
- USDA. 2020a. *Corn for Grain Yield*. U.S. Department of Agriculture. https://www.nass.usda.gov/Charts_and_Maps/graphics/cornYld.pdf [accessed June 2020].
- USDA. 2020b. Rural Energy for America Program Renewable Energy Systems & Energy Efficiency Improvement Guaranteed Loans & Grants. U.S. Department of Agriculture. <https://www.rd.usda.gov/programs-services/rural-energy-america-program-renewable-energy-systems-energy-efficiency> [accessed June 2020].
- USGS. 2011. *Wind Energy in the United States and Materials Required for the Land-Based Wind Turbine Industry From 2010 Through 2030*. U.S. Geological Survey, U.S. Department of the Interior. <https://pubs.usgs.gov/sir/2011/5036/sir2011-5036.pdf> [accessed June 2020].
- Vecoplan Midwest. 2016. *So You Want to Make Pellets?* <https://www.vecoplanmidwest.com/wp-content/uploads/2016/06/Pellet-Mill-Startup-Paged.pdf> [accessed June 2020].
- Volk, et al. 2016. *Advances in Shrub-Willow Crops for Bioenergy, Renewable Products, and Environmental Benefits*. State University of New York, College of Environmental Science and Forestry. Volk, Timothy A., Heavey, Justin P., & Eisenbies, Mark H., <https://onlinelibrary.wiley.com/doi/epdf/10.1002/fes3.82> [accessed June 2020].
- Volk, et al. 2018. *Poplar and Shrub Willow Energy Crops in the United States: Field Trial Results From the Multiyear Regional Feedstock Partnership and Yield Potential Maps Based on the PRISM-ELM Model*. *GCB Bioenergy*, Volume 10, No. 10, 735–751. Volk, Timothy A., Berguson, Bill, Daly, Christopher, Halbleib, Michael D., Miller, Raymond, Rials, Timothy G., Abrahamson, Lawrence P., et al. <https://onlinelibrary.wiley.com/doi/pdf/10.1111/gcbb.12498> [accessed June 2020].
- Walling, G. 2005. *Global Climate & Energy Project*. Advanced Coal Workshop. http://gcep.stanford.edu/pdfs/RxsY3908kaqwVPacX9DLcQ/walling_coal_mar05.pdf [accessed June 2020].
- Yoon, J. 2011. *What's the Difference between Biodiesel and Renewable (Green) Diesel*. https://advancedbiofuelsusa.info/wp-content/uploads/2011/03/11-0307-Biodiesel-vs-Renewable_Final_3_-JJY-formatting-FINAL.pdf [accessed August 2019].

1. Introduction

PURPOSE OF THE REPORT

For more than four decades, there has been growing interest in renewable energy-based approaches to strengthening rural economies, increasing energy security, and decreasing the negative environmental impacts associated with combusting fossil fuels and other production processes. There are now billions of gallons of corn- and soybean-based transportation fuels produced annually in the United States, while renewable electricity from solar, wind, and biomass sources comprises more than 10 percent of all power produced in the country.

Through this market growth, some forms of renewable energy, such as corn ethanol, solar energy, and wind energy, have achieved full commercial viability, with producers and consumers participating in well-established and stable markets. Other types of renewable energy, such as biodiesel, renewable diesel, cellulosic fuels, wood pellets, and anaerobic digesters, have achieved moderate levels of deployment; however, technical, economic, and infrastructure challenges currently limit adoption rates. Still other renewable sources, such as poplar and willow as forestry energy crops, are in nascent markets. In addition to variation in market maturity, the adoption of renewable energy varies widely by region, with all regions having a leading role in one or more types of renewable energy. There also are differences in scale, with certain renewable energy technologies best suited to rural households and individual farms, and others best suited to large-scale commercial and utility applications.

The purpose of this report is to facilitate a better understanding of the diversity and growth of today's renewable energy systems and how renewable energy affects the agricultural and forestry sectors and rural America more broadly. To meet that purpose, the U.S. Department of Agriculture's Office of Energy and Environmental Policy (in the Office of the Chief Economist) and ICF collaborated to produce this report.

RENEWABLE ENERGY TECHNOLOGIES AND FEEDSTOCKS EXAMINED

Following a chapter on the central role that public policy has played, and continues to play, in creating the conditions under which renewable energy markets can emerge and grow, the report examines seven types of renewable energy technologies and feedstocks that are applicable to the farm and forestry sectors, as well as rural communities generally. Each of the seven forms of renewable energy receives its own chapter, and the chapters are grouped into three categories:

Renewable Electricity

- Bioelectricity
- Solar
- Wind

Renewable Liquid Biofuels

- Corn Ethanol (including corn feedstocks)
- Biodiesel (including soybean feedstocks)

Feedstocks

- Agricultural and Forestry Energy Crops
 - Agricultural: Miscanthus and Switchgrass
 - Forestry: Poplar and Willow
- Wood Pellets and Wood Chips

In addition to the major renewable energy types listed above, the report includes smaller profiles of solar water heating, solar air heating, battery storage, and anaerobic digestion within the solar and bioelectricity chapters.

The report concludes with a chapter synthesizing renewable energy growth trends, the roles of public policy in advancing that growth, challenges to expanding adoption of renewable energy, and potential policy approaches for overcoming these challenges.

INFORMATION PROVIDED ON INDIVIDUAL TECHNOLOGIES AND FEEDSTOCKS

To help address market and policy questions that government agencies, agricultural and forestry organizations, and other entities may have regarding specific types of renewable energy, or renewable energy generally, each chapter synthesizes currently available information on the following topics:

1. Technical description of the technology
2. Summary of national-level trends in adoption
3. Regional distinctions in adoption and resource availability
4. Capital and operating costs
5. Significant Federal and State policies affecting adoption
6. Impacts of adoption, including direct income, expanded feedstock markets, employment, lower energy costs for end-users, greenhouse gas emission reductions, and potential negative environmental and land use effects
7. Dominant ownership or financing models
8. Challenges to extending adoption

The feedstock chapters share many of the same components, with emphases on the most favorable uses of each feedstock and the most favorable locations and conditions for its growth.

THE ROLE OF PUBLIC POLICY

The report begins with a chapter that discusses (1) the key role that Federal and State policies have played in the growth of renewable electricity, renewable liquid biofuel, and feedstock markets; (2) how these policies continue to affect national and regional deployment of renewable energy technologies and systems; and (3) the potential role for public policies to continue facilitating the growth of renewable energy markets in the future.

For example, since the late 1970s, the market for corn ethanol has been aided by a variety of tax credits, production subsidies, a Clean Air Act amendment requiring that gasoline used in automobiles be oxygenated, a California ban on a gasoline oxygenate additive, and legislation mandating that specified quantities of corn ethanol be blended into the Nation's transportation fuel supply.

Similarly, growth in the deployment of solar and wind renewable electricity systems has been aided by a mix of Federal tax credits, purchase obligations that enable systems not owned by utilities to enter electricity markets, and State-level renewable electricity supply requirements.

2. Public Policies to Incentivize Adoption of Renewable Energy in Agriculture, Forestry, and Rural America

INTRODUCTION

Renewable energy technologies can provide a unique combination of benefits to rural communities and the agricultural and forestry industries by reducing the costs of energy used by households and businesses, providing supplemental income from feedstocks and land use, increasing energy availability and resiliency, and enhancing environmental outcomes compared to conventional energy technologies. In recognition of these benefits, national, State, and local policymakers have incentivized renewable energy through various programs, some of which are agricultural- and forestry-sector specific, and some of which apply to all sectors of the U.S. economy. Key policies (i.e., those that have been influential in expediting the adoption of technologies) associated with each renewable energy technology are profiled in the individual technology chapters that occur later in this report.

This chapter is a broader summary of the policy landscape applicable to the renewable energy technologies that are most common in rural areas and in the agricultural and forestry industries. The purposes of this chapter are to assist readers in understanding and evaluating past, present, and future policy issues, including:

- Impact to date of policies on renewable energy deployment
- Status of key current policies
- Types of policies that may remain relevant over the next 5 to 10 years

The policies in this chapter apply to liquid biofuel (i.e., corn ethanol, biodiesel, and renewable diesel) and renewable electricity production, as well as feedstocks for liquid biofuels and renewable electricity.

HISTORICAL POLICY DEVELOPMENT (1970–2009)

Overview

Renewable energy policy in the United States grew out of a need to respond to national security and environmental concerns that emerged in the early 1970s. Federal policies to encourage domestic production and consumption of biofuels were implemented as a response to a series of energy crises and gasoline shortages, most notably the Organization of the Petroleum Exporting Countries (OPEC) oil embargo in 1973. Collectively, these events hindered U.S. economic growth and created challenges for U.S. foreign policy due to U.S. reliance on petroleum and oil imports.

The liquid biofuels industry is driven at the State level by blending mandates and low carbon and alternative fuel standards, and at the Federal level by the Renewable Fuel Standard (RFS). These well-established policies provide policy certainty for producers of fuels, infrastructure, and associated technology. To help support the development of biofuels and their infrastructure, grant and loan guarantee programs from the U.S. Department of Agriculture (USDA) and U.S. Department of Energy (DOE) have provided vital financial assistance to spur development and adoption.

The growth of renewable electricity production also was spurred by Federal policies established in the late 1970s and further accelerated with State programs such as Renewable Portfolio Standards (RPS)³¹ in subsequent decades. Dramatic declines in the capital costs of solar photovoltaic (PV) and wind energy systems and improvements in system performance over the past 20 years have made these

³¹ RPS establish the percentage of a State's electricity generation mix that come from renewable sources such as wind, solar, geothermal, and certain types of biomass, biogas, and hydropower. RPS can be either mandates or goals. Some States have "Clean Energy Standards" (CES) that are similar to RPS, but CES may include low-carbon or otherwise low-polluting, non-renewable electricity sources. In this chapter, RPS is used as an umbrella term that also covers CES.

renewable electricity technologies much more economically attractive, resulting in higher deployment levels and increased use of Federal policies (e.g., tax credits) to fund them. This also has helped States reach their RPS targets at much lower costs.

These historical policy developments will be examined in the following sections, starting with policies for liquid biofuels, followed by Federal and State policies for renewable electricity.

Liquid Biofuels

Since the 1970s, energy security concerns have provided policy support for the production and consumption of corn ethanol in the United States. Gasoline prices have fluctuated significantly since the 1970s and have increased over time (*exhibit 2-1*). The volatility of gasoline prices, especially price spikes, has been highly disruptive to the economy, and supporting the use of ethanol was identified as a strategy to stabilize prices through blending. A study found that ethanol blending reduced gasoline prices by an average of \$0.25 to \$0.89 per gallon between 2000 and 2010 (Du, X. & D.J. Hayes, 2011).

In 1978, the Federal Government passed the National Energy Act, which called for increased quantities of alcohol fuels to help ease current and future oil shortages and granted ethanol blends of at least 10 percent a partial exemption from the Federal motor fuels tax. Ethanol also was granted a Clean Air Act (CAA) waiver later that year (known as the “gasohol” waiver) by the U.S. Congress, which permitted blending it with gasoline up to 10 percent by volume (EPA, 2019a).³²

EXHIBIT 2-1. U.S. Gasoline Prices and Trends From 1970 Through 2014

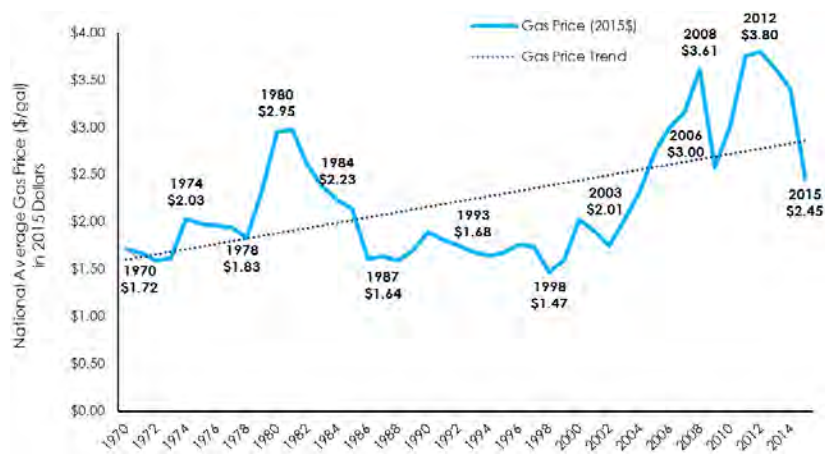

Source: Gas price data from TitleMax, n.d.

Since 1990, environmental concerns functioned as the catalyst promoting the expansion of the ethanol market. In 1990, CAA amendments instituted a national policy mandating the use of gasoline additives, which boost octane, to reduce emissions of toxic air pollutants, including benzene, toluene, and xylene. The 1990 CAA amendments left the choice of fuel oxygenate up to the gasoline refineries, but both methyl tert-butyl ether (MTBE) and ethanol were widely used, as shown in *exhibit 2-2* (Alhalabi, n.d., slide 5, EIA 2018a).³³ Heightened concerns about the public health and environmental impacts of MTBE, which was used as an oxygenate beginning in 1979, led to ethanol replacing MTBE as the primary oxygenate additive to gasoline (EIA, 2018a).

In 2005, Congress passed the Energy Policy Act that, among other tasks, amended the CAA to establish a Renewable Fuel Standard program, commonly referred to as RFS1. Environmental and human health concerns, due to the water solubility characteristics of MTBE, resulted in legislative language that did not provide gasoline refiners using MTBE legal protections regarding claims filed after the Act became law (H.R. 6, 2005). In addition, State regulators were already banning the use of MTBE as a fuel oxygenate, and by 2008, 23 States had adopted either complete or partial bans on MTBE (EPA, 2007).

³² The Energy Tax Act, part of the National Energy Act passed in 1978, also introduced an excise tax exemption for “gasohol” (known today as ethanol), reducing the tax per gallon by nearly one-third.

³³ Other fuel oxygenates included tert-butyl formate (TBF), diisopropyl ether (DIPE), tert-butyl alcohol (TBA), ethyl tert-butyl ether (ETBE), tert-amyl methyl ether (TAME), and methanol.

These two substantial changes in the policy landscape drastically influenced refiners to halt their use of MTBE and instead adopt ethanol, which led to a complete drop-off in MTBE by 2008, as seen in *exhibit 2-2* (EIA, 2018a). Policymakers had two primary goals in mind when designing and implementing RFS1—improving U.S. energy security and decreasing transportation sector greenhouse gas (GHG) emissions (EPA, 2019b).

In terms of energy security, the United States, has made significant progress since 2005 to (1) reduce oil imports, and (2) increase domestic production of oil and petroleum products, as well as ethanol. A sharp decline in oil imports, while simultaneously increasing fuel production domestically (see *exhibit 2-3*), show that policies discussed in this section have had a material impact on the goal of eventually achieving energy independence in the long term.

EXHIBIT 2-2. U.S. Inputs of MTBE and Fuel Ethanol (1993–2017)

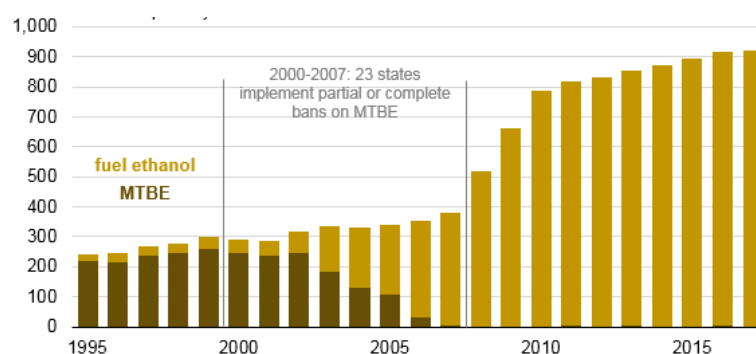

Source: EIA, 2018a

EXHIBIT 2-3. U.S. Imports and Production of Petroleum and Ethanol Production (1970–2018)³⁴

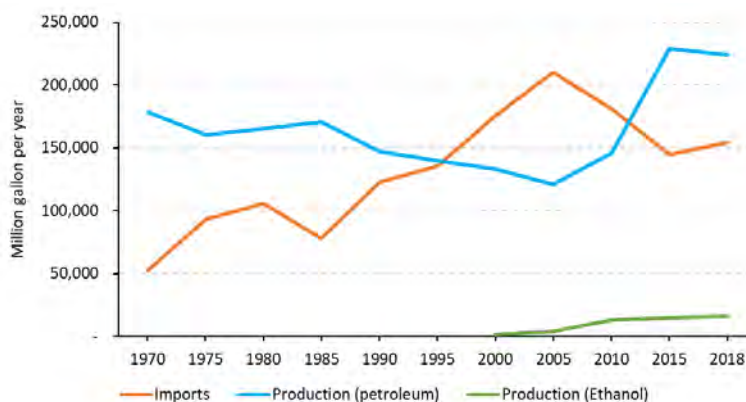

Sources: DOE, 2020a; EIA, 2019.

Federal Policies: Renewable Electricity

The National Energy Act of 1978 included three important statutes that promoted the use of renewable electricity: (1) the Public Utility Regulatory Policies Act of 1978 (PURPA), (2) the Energy Tax Act of 1978, and (3) the National Energy Conservation Policy Act of 1978.

PURPA marked a major shift in U.S. electric utility regulatory policy. At the time that the Act was passed, the electric utility industry was dominated by natural monopolies—large, vertically integrated utilities that controlled electric generation, transmission, and distribution in a designated geographic location. In the context of renewable electricity, one of the most important provisions in PURPA was a section obligating utilities to purchase electricity generated by power production facilities of 80 megawatts (MW) or less, and cogeneration facilities, collectively referred to as “qualifying facilities” (QFs). This provision enabled renewable, non-utility electricity generators to enter electricity markets and started a chain of events that led to the restructuring and deregulation of U.S. electricity markets.

The Energy Tax Act created one of the most prominent renewable energy policies—tax credits for renewable energy resources. After the shocks of the 1973 oil embargo and other early 1970s turmoil in energy markets, policies began to focus on energy security and conservation. These tax credits were the product of a shift away from incentivizing oil and gas through tax policy, and instead beginning to incentivize energy efficiency and alternative sources such as wind, solar, and geothermal for businesses

³⁴ From the mid-1980s onward, annual U.S. crude oil and petroleum product imports steadily increased until 2005, when they peaked at just over 0.2 billion gallons per year. Since 2005, U.S. imports of these oil products have declined, with a slight increase in 2018.

and homeowners as a means for bringing these technologies toward greater commercialization. The tax credits were altered and extended multiple times in the subsequent decades.

The National Energy Conservation Policy Act was meant “to reduce the growth in demand for energy, and to conserve non-renewable energy resources without inhibiting beneficial economic growth” (H.R. 5037, 1978). The Act largely focused on energy efficiency studies and initiatives, but it also included provisions for advancing solar energy systems. Federal loan guarantees were made available for solar energy installations in single- and multi-family homes. A Federal demonstration program for solar heating and cooling was created, and Federal agencies were directed to give preference in their leasing decisions to buildings with solar and renewable energy installations that could reduce life cycle costs. The Federal Photovoltaic Utilization Act was included in this Act and authorized the Secretary of Energy to make annual procurements of solar arrays for Federal facilities such that it would bring down the cost curve of producing PV technology.

The Energy Policy Act of 1992 created the production tax credit (PTC) for wind and closed-loop biomass and extended the investment tax credit (ITC) indefinitely for geothermal, PV, and certain other solar technologies.

State Policies: Renewable Electricity

Increasing awareness of environmental issues and a desire for energy diversification simultaneously led to State-level policies to support the renewable energy sector. In 1983, Iowa adopted the first RPS (NCSL, 2020). Currently, 30 States and Washington, D.C., have enacted mandatory RPS programs that have helped drive more than half of the growth in renewable electricity since 2000 (NCSL, 2020).

CURRENT POLICY LANDSCAPE (2010–2020)

This section highlights current policies at the Federal and State levels driving the expansion of liquid biofuels, as well as wind, solar, and biomass electricity generation.

Federal Policies: Liquid Biofuels

Three main categories of national policies are discussed in this section: RFS, ethanol blending mandates, and other Federal incentive policies.

Renewable Fuel Standard (RFS)

In 2010, the RFS was updated and referred to as “RFS2.” RFS2 emphasized the development and use of advanced biofuels, including cellulosic biofuel and biomass-based diesel. One primary reason for this emphasis was that advanced biofuels were only marginally developed; therefore, advanced biofuel statutory volume requirements were added to spur their development and continue addressing transportation emissions, which accounted for approximately 28 percent of total U.S. GHG emissions in 2017 (EPA, 2020).

EXHIBIT 2-4. Renewable Fuel Standard 2: Original Statute and Reset Volumes

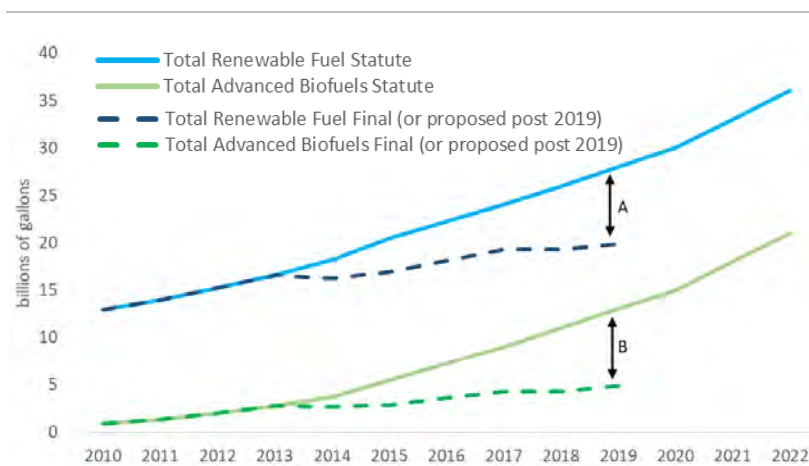

Source: CRS, 2019, p. 7.

The RFS2 program has been a major factor in increasing the use of renewable fuels in the transportation sector and, as a result, pushing the biofuels industry toward more consistent and stable growth. Under RFS1 and RFS2, the volume of renewable fuel produced domestically more than doubled from 2007 to 2013. However, from 2014 to 2019, while liquid biofuels continued to grow, the total renewable fuel

statutory targets have not been achieved (CRS, 2019, p. 1). In particular, the advanced biofuel targets have consistently fallen short. As can be seen in *exhibit 2-4*, the advanced biofuel shortfall accounts for the vast majority of the overall RFS underperformance.

Ethanol Blending Mandates

According to EIA, as of 2016, almost all U.S. gasoline was blended with 10 percent ethanol. Specifically, more than 95 percent of gasoline consumed by gasoline-vehicles used E10 (EIA, 2016). Once E10 saturated the market – meaning that the majority of U.S. gasoline had blends of 10 percent ethanol – the only way to increase ethanol use, beyond relying on growth in national motor gasoline consumption, was to approve higher ethanol-gasoline blends. In June 2011, the U.S. Environmental Protection Agency (EPA) passed an E15 partial waiver, which allowed the ethanol content of gasoline to contain between 10.5 percent and 15 percent by volume (EPA, 2019a). Initially, E15 was only approved for passenger cars, light trucks, and medium-duty vehicles made in model years 2001 through 2006. It was subsequently amended to include all model years of these vehicle types made since 2001. Fueling stations are not required to sell E15; however, more stations are beginning to offer E15, especially as equipment grants and more favorable profit margins develop.

An even higher ethanol blend called “E85,” which contains between 51 percent to 83 percent ethanol, was approved for flexible-fuel vehicles, which are designed for the higher ethanol fuel blends (DOE, 2019a). In 2019, to aid in the adoption of E15, EPA approved the use of the Reid vapor pressure (RVP) waiver year-round. This regulation allows year-round E15 sales without additional RVP control (EPA, 2019c).

Other Federal Incentive Policies

Exhibit 2-5 describes several Federal programs that provide grants and loans to biofuel producers to support feedstock supply, biofuel production, and infrastructure development. In general, these Federal incentive programs apply to both ethanol and biodiesel; however, certain policies, such as the Biorefinery, Renewable Chemical, and Biobased Product Manufacturing Assistance program, are eligible only for cellulosic ethanol.

EXHIBIT 2-5. Federal Financial Programs for Biofuels

Federal Incentive Programs	Description
Advanced Biofuel Feedstock Incentives	The Biomass Crop Assistance Program (section 9010) offers financial support to owners and operators of agricultural land who plan to produce biomass feedstock. Financial assistance comes in two forms: (1) a maximum of 50 percent reimbursement for the cost to develop a biomass feedstock crop and annual payments for up to 5 years; and (2) matching payments for the collection, harvesting, storage, and delivery of feedstocks to biomass conversion facilities (e.g., E85) (USDA, 2020a).
Biorefinery, Renewable Chemical, and Biobased Product Manufacturing Assistance Program	This loan guarantee program provides funding for either the development and construction, or retrofitting of facilities producing or slated to produce, advanced ethanol, including biodiesel and cellulosic ethanol (USDA, 2020b).
Alternative Fuel Vehicle Refueling Property Credit	This is a 30 percent credit, up to \$30,000, for the cost of installing alternative fuel pumps (e.g., E85 fuel pump) (IRS, 2020).
Ethanol Infrastructure Grants and Loan Guarantees	The Rural Energy for America Program offers loan guarantees and grants to agricultural producers and small businesses. Funding for renewable energy systems, including ethanol production systems, may be eligible for grants ranging from \$2,500 up to \$500,000, as well as loan guarantees ranging from \$5,000 to \$25 million (subject to congressional appropriations) (USDA, 2020c).
Improved Energy Technology Loans	Funded by DOE, this program provides loan guarantees, up to 100 percent of the amount requested, to support nascent advanced technologies, including biofuels (DOE, 2020b).
Value-Added Producer Grants (VAPG)	VAPG offer either planning or working capital grants that support independent agricultural producers, farmer and rancher cooperatives, agricultural producer groups, and majority-controlled producer-based business ventures (DOE, 2020b).

Federal Policies: Renewable Electricity

Four types of national policies are profiled in this section: investment and production tax credits, accelerated tax depreciation, PURPA renewable purchasing mandates for utilities, and rural loans and grants. Historically, high upfront costs for renewable electricity projects have been a barrier to adoption, particularly at the farm scale. To encourage adoption, several Federal policies focus on lowering these initial investment barriers.

Tax Credits

The ITC is available to businesses and individuals to help reduce the net capital costs of adopting renewable energy technologies, including solar, wind, and biomass electricity generation. The ITC was set to decrease from 30 percent to 10 percent of eligible solar and wind capital costs in 2017; however, it was extended through the Consolidated Appropriations Act of December 2015. The ITC is 30 percent for all solar and wind projects that met construction commencement milestones as defined by the IRS by December 31, 2019. For projects reaching those milestones in 2020, the ITC is 26 percent, and it will drop to 22 percent in 2021. Ultimately, the ITC is set to decline to (and remain at) 10 percent for business-owned systems and 0 percent for personally owned systems beginning in 2022 (NCCETC, 2018a).

For biomass, the ITC currently provides a tax benefit to offset 10 percent of the capital cost of eligible combined heat and power (CHP) projects. The credit includes CHP systems up to 50 MW in capacity, with certain restrictions and reductions for large systems within the overall 50-MW capacity limit. This credit is set to phase out at the end of 2021 (NCCETC, 2018a).³⁵

The PTC was also renewed and extended through the Consolidated Appropriations Act of December 2015, although the value of the PTC is dictated by a different schedule than the ITC. The PTC is paid based on electricity produced each year by wind energy systems for the first 10 years of system operation. The PTC value (\$/kWh) is based on the year that the wind energy system commences construction, with a value of approximately \$0.015/kWh for systems commencing construction in 2020 (DOE, 2020c).³⁶ The PTC received a 1-year extension at the end of 2019, reviving the expired biomass PTC and extending the wind PTC to the end of 2020. For more information on the rate of PTC compensation for closed-loop and open-loop biomass power generators, see the Federal Policies sub-section of chapter 3.

EXHIBIT 2-6. Historical Wind Deployment Variability and the Production Tax Credit

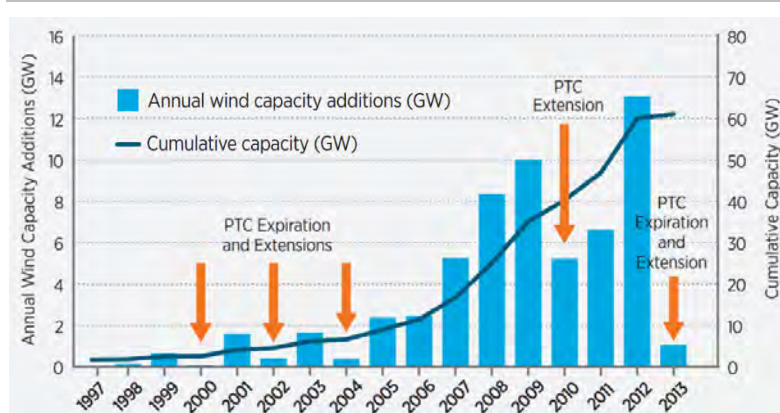

Source: DOE, 2015, p. Xxxvi.

While State policies, as well as improvements in technology cost and performance, are expected to continue to support wind system development, the growth in installed wind capacity has the potential of declining in the near term without the PTC. As seen in exhibit 2-6, the PTC has expired (or was set to expire) on five previous occasions (2000, 2002, 2004, 2010, and 2013). In each instance, there was a sharp

³⁵ The ITC can be applied to the tax liability of the system owner in the year that the system becomes operational or the prior tax year, or carried forward for up to 20 years.

³⁶ A project can demonstrate that it has commenced construction to qualify for the PTC or ITC through the Physical Work Test (a project may pay to perform physical work of a significant nature) or the 5 percent Safe Harbor Test (a project incurs 5 percent of eligible project costs). Both methods must also meet a continuity requirement, where progress must be continuously made toward completion of the project in order to claim the tax credits (IRS, 2019). Wind projects can claim the Federal investment tax credit (with a phase-out schedule comparable to the PTC) in lieu of the PTC; however, that is rarely done for utility-scale wind projects for economic reasons (NCCETC, 2019a).

decrease in new installed wind capacity. Conversely, when Congress has reinstated the PTC, new installed wind capacity increased.

Accelerated Tax Depreciation: Modified Accelerated Cost-Recovery System (MACRS)

MACRS allows renewable energy system owners to depreciate new renewable assets at a faster pace than typical investments, which improves the net present value of renewable investments. Most renewable assets may be depreciated over 5 years, except for biomass assets, which are often depreciated over 7 years. However, a wide swath of technologies involved in the biomass energy supply chain qualify for MACRS. These technologies include assets used in the conversion of biomass to heat, or to a solid, liquid, or gaseous fuel, as well as equipment and structures used to receive, handle, collect, and process biomass (NCCETC, 2018b). Certain renewable energy projects placed in service **between September 28, 2017, and December 31, 2022, can elect 100 percent “bonus depreciation”** (i.e., full expensing of renewable investments in the first year) (NCCETC, 2018b).

USDA Rural Loan Guarantee and Grant Programs

There are multiple Federal incentives specific to rural America that are administered by USDA and that apply to wind, solar, and biomass power generation, as well as many other renewable technologies. For example, USDA's Rural Energy for America Program provides loan guarantees and grants to agricultural producers and small rural businesses to construct renewable energy projects, including those powered by biomass, wind, and solar (USDA, 2020c). USDA's Forest Service administers the Community Wood Energy and Wood Innovation Program, which uses grants to expand wood energy markets and reduce wildfire risks. There is also the USDA Rural Energy Savings Program, which supports loans to rural households and businesses, through their rural utilities, and was extended to on-grid and off-grid renewable electricity technologies. For more information on these programs, see the Federal Policies sub-section of chapter 3.

[State Policies: Liquid Biofuels](#)

In addition to Federal policies, State-level policies have also been key drivers in growing the ethanol and biodiesel industries in some States. Policies designed to decarbonize the transportation sector at the State level can be grouped into two categories: low carbon fuel standard (LCFS) and alternative fuel standards (AFS). LCFS programs seek to reduce the carbon intensity of transportation fuels and are generally neutral with respect to the specific type of fuel used, as long as its carbon intensity achieves a certain reduction compared with that of conventional fossil fuels. AFS programs typically operate by specifying a type of fuel and mandating its use in a predetermined percentage.

Few States currently have LCFS and AFS programs in place; however, the policies are influential due to the aggregate size of participating States and the trend toward more States considering similar programs. California's LCFS, in effect since 2009, and Oregon's Clean Fuels Program, in effect since 2016, have encouraged the use of low carbon fuels through a market-based credit and deficit mechanism. Minnesota's Biodiesel Blend Mandate has seasonal blending requirements, requiring that all diesel sold in the State between April and September must contain at least 20 percent biodiesel by volume (B20) and, for the remaining months, all diesel must contain at least 5 percent of biodiesel (B5) (Minnesota Legislature, 2018).

More States are considering, or are implementing, similar policies. New York recently introduced legislative bill A5262/S4003—a version of an LCFS that was not approved in its first round (New York State Senate Bill S4003, 2019). Washington State introduced HB 1110, a program very similar to California's LCFS, which calls for a 20 percent reduction, relative to 2017, in transportation fuels carbon intensity by 2035. Currently, the legislation was reintroduced and has passed the State's House of Representatives and is waiting for a vote in the State Senate. With the passage of Senate Bill 6508 in 2006, Washington State requires that total gasoline volume in the State contains a minimum of 2 percent ethanol (Washington Senate Bill 6508, 2006, p. 3). Hawaii is also developing an AFS, requiring that 20 percent

and 30 percent of highway fuel demand be met with alternative fuels by 2020 and 2030, respectively (H.B. 2699, 2020, section 6). Lastly, Louisiana's RFS set minimum ethanol, biodiesel, and alternative renewable fuel content requirements. This standard goes into effect once ethanol and biodiesel equal or exceed a minimum annualized in-State production volume of 50 million and 10 million gallons, respectively (Louisiana State Legislature, 2012). Exhibit 2-7 shows States with an LCFS or AFS in place.

Various State tax credit and tax exemption programs are also helping to spur biofuel production, infrastructure expansion, and end-use adoption at the State level. Currently, 31 States have adopted a tax-related incentive program,³⁷ whether it is aimed specifically at the production of biofuels, increasing infrastructure, or incentivizing consumers to adopt biofuel-capable vehicles (DOE, 2019b).

EXHIBIT 2-7. U.S. State Low Carbon Fuel Standards



Source: C2ES, 2019.

State Policies: Renewable Electricity

To encourage the adoption of wind, solar, biomass, biogas, and other renewable electricity generating systems, States have tended to adopt three types of policy measures: generation mix mandates, financial incentives, and enabling policies. The mandates are in the form of RPS programs and associated, State-sponsored renewable procurements, while financial incentives include tax credits, tax exemptions, loans, feed-in-tariffs, and other programs. These policies all work to facilitate renewable electricity growth at the State level and help States achieve broader environmental, energy resiliency, and economic development goals.

Renewable Portfolio Standards (RPS)

Currently, 30 States and the District of Columbia have mandatory RPS policies (NCSL, 2020); see exhibit 2-8 for RPS levels as of 2019. The intent of these policies is to ensure that a certain percentage of a State's retail electricity sales comes from renewable sources. Some States break down their overall targets into two or more compliance tiers or classes. In most cases, Tier 1 requirements are intended to incentivize wind and solar, and in some cases, other renewable technologies. Tier 2 or 3 requirements often apply to a broader range of energy sources (e.g., renewables plus waste-to-energy) or

³⁷ States that have adopted biofuel tax incentive programs are Alabama, Colorado, Delaware, Florida, Georgia, Hawaii, Idaho, Illinois, Indiana, Iowa, Kansas, Kentucky, Louisiana, Maine, Michigan, Montana, Nebraska, New Mexico, New York, North Carolina, North Dakota, Oklahoma, Oregon, Rhode Island, South Carolina, South Dakota, Texas, Virginia, Washington, Wisconsin, and Wyoming.

incorporate resources from out-of-State generators. Within a tier, States may impose “carve-outs,” or minimum requirements for specific technologies, such as solar. Not all States include biomass as a renewable source in their RPS mandates. Eligible biomass is often limited to “sustainable” biomass, the definition of which is not uniform across States.

EXHIBIT 2-8. Map of Mandatory Renewable Portfolio Standards

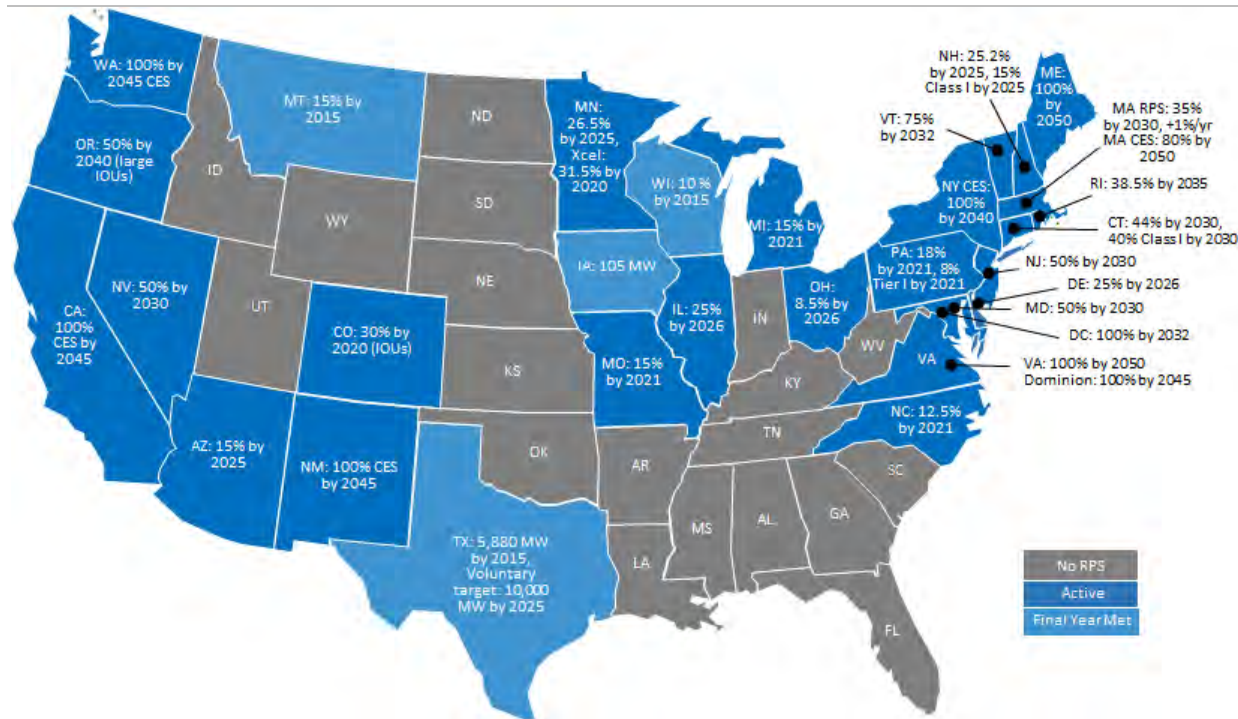

Source: ICF

Nationally, the role of RPS policies has diminished over time, but remains significant. RPS policy-related new projects represented approximately 34 percent of all U.S. renewable capacity additions in 2017, as shown in exhibit 2-9. However, that is down from a peak of nearly 80 percent a decade earlier, when renewable deployment was a much smaller part of the overall U.S. generation mix.

Most RPS policies were established in the early 2000s, and four States have already reached their final target years. Four more States (Michigan, Missouri, North Carolina, and Pennsylvania) will reach their terminal year by 2021 unless they act to extend their programs. In contrast, Connecticut, Maryland, Massachusetts, Nevada, and New Jersey recently increased their RPS requirements, while California, Maine, New Mexico, New York, Virginia, and Washington adopted 100 percent renewable or clean energy mandates.³⁸ This trend of States adopting long-term goals of 50 percent to 100 percent

EXHIBIT 2-9. Annual Renewable Capacity Additions

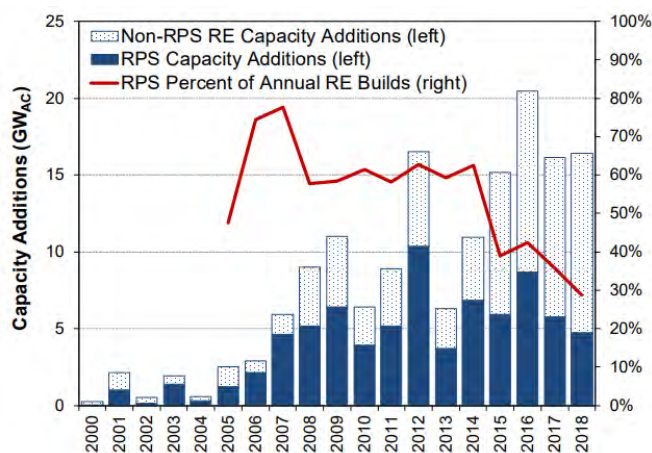

Source: LBNL, 2019, p. 17.

³⁸ Clean Energy Standards are similar to Renewable Portfolio Standards, but typically include nuclear energy and large hydro energy in their portfolios of qualifying generation technologies.

clean energy by 2030 or later means that RPS are expected to remain important drivers of renewable energy development for at least the next decade.

Net Metering and Feed-in-Tariffs

Net metering policies identify eligibility and compensation rules for selling any excess electricity from on-site generators back to the utility grid. Net metering programs are widely available in the United States, with 39 States and the District of Columbia offering net metering at compensation levels that vary from the full retail electricity rate to much lower wholesale-based rates (NCCETC, 2019b). In contrast, feed-in-tariffs offer a set compensation rate for all on-site generation delivered to the grid for the duration of a contract. Feed-in-tariffs for renewable electricity have proven to be less common in the United States than net metering, with only a handful of States and utilities offering them, such as California, Oregon, and Washington. For more information on net metering and feed-in-tariffs (e.g., the California Bioenergy Market Adjusting Tariff [BioMAT] program), see chapter 3.

Property Assessed Clean Energy (PACE) Financing

More than 30 States authorize PACE financing, in which property owners receive a loan for construction of a clean energy asset and repay the loan through their property tax bill (DOE, 2017). Although solar and energy efficiency technologies are typical candidates for PACE financing, States such as Ohio include biomass electricity assets on their eligible resource list (NCCETC, 2018c).

Other State Direct Incentive Policies

There is a wide range of other State financial incentives for renewable electricity projects, as well as local government and utility incentives. *Exhibit 2-10* provides a sampling of State-level incentives.

EXHIBIT 2-10. Examples of State-Level Financial Incentives for Renewable Electricity

State	Incentive Program Name	Incentive Description
Georgia	Biomass Sales and Use Tax Exemption	100 percent sales and use tax exemption for biomass materials utilized in the production of energy in the commercial and residential sectors (NCCETC, 2015a).
Hawaii	Farm and Aquaculture Alternative Energy Loan	Farmers and aquaculture entities may receive loans for projects involving PV energy, hydroelectric power, wind power generation, methane generation, and biodiesel and ethanol production. Loans may provide up to 85 percent of the project cost (up to a maximum of \$1,500,000) for a term of up to 40 years (NCCETC, 2014a).
Massachusetts	Commonwealth Organics-to-Energy Program	Organics-to-Energy grants support the use of anaerobic digestion and other technologies that convert source-separated organic wastes into electricity and thermal energy. The program covers technical and feasibility studies, pilot projects, proposal review, and implementation (NCCETC, 2017a).
New Mexico	Biomass Equipment and Materials Compensating Tax Deduction	The value of 100 percent of biomass equipment and materials may be deducted for the purposes of calculating the compensating tax due. This is equivalent to a sales and use tax exemption (NCCETC, 2016a).
Oregon	Biomass Producer or Collector Tax Credit	This tax credit for agricultural producers or collectors of biomass may be applied when biomass is used in facilities to produce electricity or biofuels (NCCETC, 2016b).
Pennsylvania	Alternative and Clean Energy Program	This program supports alternative energy and clean energy projects in the form of loans, grants, and loan guarantees, primarily applying to wind, geothermal, and biomass fuels (NCCETC, 2015b).
Rhode Island	Agricultural Energy Program	The program provides grants up to \$20,000 to help with the direct costs associated with project implementation. Higher priority will be given to non-utility scale, or non-large-scale commercial projects that demonstrate predominately agriculturally related renewable energy use (NCCETC, 2017b).
South Carolina	Biomass Energy Tax Credit (Corporate)	A credit against the income tax of 25 percent of the purchasing or installation cost of equipment used to create heat, steam, or electricity from biomass resources (NCCETC, 2015c).
Texas	Franchise Tax Exemption	"Companies in Texas engaged solely in the business of manufacturing, selling, or installing solar or wind energy devices are exempt from the franchise tax" (NCCETC, 2015d).
Vermont	Agricultural Energy Loan Program	This program provides loans to agriculture- or forest product-based companies for renewable energy and energy efficiency projects. The maximum loan amount is \$2,000,000 (NCCETC, 2016c).
West Virginia	Partial Business and Operation (B&O) Tax Exemption	"An effective B&O tax rate on wind-powered turbines that is about 30 percent of the effective tax rate of most other types of newly constructed generating units" (NCCETC, 2015e).

Enabling Policies

Both direct financial incentive policies and enabling policies facilitate faster, lower cost, more predictable, or less complex development of renewable electricity projects. For example, transmission or distribution line extension analysis policies, which have been enacted in States such as Arizona, Colorado, New Mexico, and Texas, require utilities to provide off-grid customers with cost estimates for a line extension to the grid compared with the cost of alternative renewable options (NREL, 2008, pp. 40-41). This example of an “enabling policy” can help farmers and ranchers determine when it may be economical to build an on-site renewable system rather than connecting to the existing grid. Interconnection standards in New Jersey that allow wind projects in industrial zones and near piers are another example of an enabling policy (NCCETC, 2014b).

Enabling policies can make the difference between the viability and non-viability of a given renewable project, and they differ significantly across the country. Standardized, efficient, and low-cost interconnection, electrical permitting, environmental, and land use approval processes all facilitate the adoption of renewable energy systems. Incorporating battery storage into renewable projects can be another enabling policy issue. For example, States have encouraged integration of battery storage with renewable technologies by providing guidance for utilities to include storage in their resource planning (Washington State) and amending interconnection rules to encourage on-site consumption of solar power (Hawaii) (Twitchell, 2019). Those policies support higher levels of renewable capacity on the electric grid by increasing the role of batteries to store solar or wind power and dispatch it at times of greatest need on the grid.

FUTURE DIRECTION AND INTENDED IMPACTS OF CURRENT POLICIES

Liquid Biofuels

The main goal of renewable fuel policies related to the RFS2 program was to encourage the maturation of advanced biofuels (i.e., renewable fuels that achieve at least a 50 percent reduction in life cycle GHG emissions compared with a 2005 petroleum baseline) (EPA, 2019d). In the past 2 years, EPA has approved a wider scope of advanced biodiesel pathways, such as biodiesel from distiller sorghum oil. The intent is to encourage more advanced biodiesel production.

The original RFS2 statute only set volume targets through 2022. What the post-2022 RFS program will look like is uncertain. EPA will determine the appropriate targets for the four categories of renewable fuels (biomass-based diesel, cellulosic biofuel, advanced biofuel, and total renewable fuel) based on the original goals of RFS, biofuel industry historical trends, and future projections.

Another applicable policy is the Biodiesel Tax Credit (BTC), which offers qualified biodiesel producers and blenders an income tax credit of \$1 per gallon of biodiesel or renewable diesel. Originally, the BTC was slated to expire at the end of 2017; however, the U.S. Senate approved its extension to 2022 through appropriations legislation in 2019. Currently, the tax credit is capped at a per company level of \$10 million per year (EIA, 2020).

In ethanol production, there is a growing interest in increasing the utilization of corn stover,³⁹ which can be processed into ethanol. The use of corn stover to produce cellulosic ethanol is still a nascent technology, with only two approved pathways under California's LCFS program as of June 2019. Equipping ethanol refineries to process stover into cellulosic ethanol is likely to improve the overall economics and sustainability of corn ethanol producers and farmers. In addition, ethanol derived from corn stover has a low carbon intensity relative to conventional corn ethanol (EWG, 2015, p. 5), which would garner a greater value in States that have low carbon fuel standard programs in place (e.g.,

³⁹ Corn stover is comprised of material from all parts of the corn plant except the actual corn, including the husks, cobs, leaves, and stocks (i.e., non-edible parts) that were traditionally left in the field. Corn stover is one of the primary feedstocks used to produce cellulosic ethanol in the United States (AGMRC, 2009).

California's LCFS). In addition, the USDA's Agriculture Innovation Agenda has indicated a goal of increasing market-driven ethanol blending rates to E15 by 2030 and E30 by 2050 (USDA, 2020d, p. 4).

LCFS-like policies will almost certainly continue to emerge as more States continue to address transportation sector GHG emissions and increase domestic fuel production. The designs of State programs will vary. Based on those in place or under consideration, however, the approach will likely be to incentivize transportation fuel producers to manufacture lower carbon intensity fuels.

Renewable Electricity

It is uncertain whether Congress will increase the ITC after it declines to 10 percent for business-owned systems and 0 percent for household-owned systems in 2022, or if Congress will extend the PTC beyond its expiration for renewable systems commencing construction in 2020. There also are multiple debates at the State level, at the Federal Energy Regulatory Commission (FERC), and in Congress on how to adjust PURPA implementation given the increasing cost-competitiveness of wind and solar.

PURPA continues to be an important driver of renewable energy development in select States. As the costs of solar power have come down, PURPA has driven utility-scale solar installations in select States—primarily North Carolina, California, and Utah (EIA, 2018b). Going forward, it is expected that PURPA will be a smaller driver of renewable projects due to adjustments in PURPA compensation rates and restrictions on maximum project sizes and fixed-price contract lengths being pursued in several markets. FERC released a Notice of Proposed Rulemaking in 2019 that seeks to change the rates that are received by PURPA QFs, which are currently fixed rates meant to capture the avoided cost of generation at a centralized utility facility. FERC proposed making those rates flexible and set by States based on market conditions or State-determined timelines. Changes to the avoided cost financing mechanism currently provided by PURPA will introduce risk into project financing and could cause complications for renewable energy developers.

The future role of biomass electricity generation policies is somewhat uncertain. Although the Federal Government is planning to treat certain types of biomass generation as carbon neutral, the scientific debate around the carbon neutrality of different biomass feedstocks and electricity applications continues (Biomass Magazine, 2020). Key questions going forward for biomass power generation will be whether and how States with RPS continue to include biomass as an eligible technology in their requirements, especially as these programs are revised and expanded.

As government incentives, as well as technology cost and performance improvements, have led to increasing solar and wind deployment, large-scale projects have raised land competition issues with agriculture. In particular, land competition issues arise for large solar projects that can remove 100 or more acres of land from traditional agricultural use, and thereby may alter the nature of economic activities in rural communities and local tax revenues. For example, in 2017, legislation was introduced in Connecticut to restrict the use of incentives for solar arrays on farmland (Connecticut Senate Bill 412). In Oregon, the Land Conservation and Development Commission approved rules to restrict commercial solar facilities on high-value farmland (PV Magazine, 2019). In response to these types of concerns, solar developers have been expanding dual-use opportunities at solar project sites, such as pollinator programs that plant flowers with high wildlife value under solar arrays (Reuters, 2019).

Increasing deployment of solar and wind energy systems has also led to load balancing concerns on electricity transmission and distribution grids. That is because the output of these renewable energy systems varies throughout the day based on sunlight and wind speed patterns. A wide range of policies, as well as technical innovations, are available to manage load imbalances between power supply and demand on the grid (BPC, 2013, p. 28). Such policies are becoming increasingly important as complements or substitutes for expanding transmission and distribution grids (DOE, 2020d).

REFERENCES

- AGMRC. 2009. Corn Stover. Agricultural Marketing Resource Center. <https://www.agmrc.org/renewable-energy/feedstocks-biofuels/annual-crops/corn-stover> [accessed September 2019].
- Alhalabi, Matt. n.d. *MTBE and Ethanol: History and Environmental Impact*. Missouri Department of Natural Resources. <https://dnr.mo.gov/env/hwp/docs/mtbepresentation.pdf> [accessed March 2020].
- Biomass Magazine. 2020. Senate Hearing Addresses Wood Stoves, RFS and Biomass Neutrality. <http://biomassmagazine.com/articles/17079/senate-hearing-addresses-wood-stoves-rfs-and-biomass-neutrality> [accessed May 2020].
- BPC. 2013. *Policies for a Modern and Reliable U.S. Electric Grid*. Bipartisan Policy Center. https://bipartisanpolicy.org/wp-content/uploads/2019/03/Energy_Grid_Report1.pdf [accessed May 2020].
- C2ES. 2019. State Climate Policy Maps. Center for Climate and Energy Solutions. <https://www.c2es.org/content/state-climate-policy/> [accessed July 2019].
- Connecticut Senate Bill 412. *An Act Restricting the Use of Incentives for the Development of Solar Arrays on Agricultural Land*. https://www.cga.ct.gov/asp/cgabillstatus/cgabillstatus.asp?selBillType=Bill&bill_num=SB00412&which_year=2017 [accessed July 2019].
- CRS. 2019. *The Renewable Fuel Standard (RFS): An Overview*. Congressional Research Service. <https://crsreports.congress.gov/product/pdf/R/R43325> [accessed July 2019].
- DOE. 2015. *Wind Vision: A New Era for Wind Power in the United States*. U.S. Department of Energy. https://www.energy.gov/sites/prod/files/WindVision_Report_final.pdf [accessed July 2019].
- DOE. 2017. *Commercial Property Assessed Clean Energy (C-PACE): A Fact Sheet for State and Local Governments*. U.S. Department of Energy. https://www.energy.gov/sites/prod/files/2017/10/f39/FL1710_WIP_CPACEv2.PDF. [accessed September 2019].
- DOE. 2019a. Ethanol Blends. U.S. Department of Energy. https://afdc.energy.gov/fuels/ethanol_blends.html [accessed July 2019].
- DOE. 2019b. Biodiesel Laws and Incentives. U.S. Department of Energy. <https://afdc.energy.gov/fuels/laws/BIOD> [accessed July 2019].
- DOE. 2020a. U.S. Ethanol Plant Count, Capacity, and Production. U.S. Department of Energy. <https://afdc.energy.gov/data/10342> [accessed June 2020].
- DOE. 2020b. Loan Programs Office. U.S. Department of Energy. <https://www.energy.gov/lpo/loan-programs-office> [accessed May 2020].
- DOE. 2020c. Production Tax Credit and Investment Tax Credit for Wind. U.S. Department of Energy. <https://windexchange.energy.gov/projects/tax-credits> [accessed April 2020].
- DOE. 2020d. Renewable Energy Integration. U.S. Department of Energy. <https://www.energy.gov/oe/services/technology-development/renewable-energy-integration> [accessed May 2020].
- Du, X. & D.J. Hayes. 2011. *The Impact of Ethanol Production on US and Regional Gasoline Markets: An Update to May 2019*. The Center for Agricultural and Rural Development, Iowa State University. <https://www.card.iastate.edu/products/publications/pdf/11wp523.pdf> [accessed June 2020].
- EIA. 2016. Almost all U.S. Gasoline is Blended with 10% Ethanol. U.S. Energy Information Administration, DOE. <https://www.eia.gov/todayinenergy/detail.php?id=26092> [accessed June 2020].
- EIA. 2018a. The United States Continues to Export MTBE, Mainly to Mexico, Chile, and Venezuela. U.S. Energy Information Administration, DOE. <https://www.eia.gov/todayinenergy/detail.php?id=36614> [accessed March 2020].
- EIA. 2018b. **PURPA-Qualifying Capacity Increases, But It's Still a Small Portion of Added Renewables**. U.S. Energy Information Administration, DOE. <https://www.eia.gov/todayinenergy/detail.php?id=36912> [accessed July 2019].
- EIA. 2019. U.S. Petroleum, Consumption, Production, Imports, Exports, and Net Imports, 1950–2018. U.S. Energy Information Administration, DOE. <https://www.eia.gov/energyexplained/oil-and-petroleum-products/imports-and-exports.php> [accessed March 2020].
- EIA. 2020. U.S. Biomass-based Diesel Tax Credit Renewed through 2022 in Government Spending Bill. U.S. Energy Information Administration, DOE. <https://www.eia.gov/todayinenergy/detail.php?id=42616> [accessed June 2020].
- EPA. 2007. *State Actions Banning MTBE (Statewide)*. U.S. Environmental Protection Agency. <https://nepis.epa.gov/Exe/ZyNET.exe/P1004KIR.TXT?ZyActionD=ZyDocument&Client=EPA&Index=2006+Thru+2010&Docs=&Query=&Time=&EndTime=&SearchMethod=1&TocRestrict=n&Toc=&TocEntry=&QField=&QFieldYear=&QFieldMonth=&QFieldDay=&IntQFieldOp=0&ExtQFieldOp=0&XmlQuery=&File=D%3A%5Czyfiles%5CIndex%20Data%5C06thru10%5Ctxt%5C0000009%5CP1004KIR.txt&User=ANONYMOUS&Password=anonymous&SortMethod=h%7C->

&MaximumDocuments=1&FuzzyDegree=0&ImageQuality=r75g8/r75g8/x150y150g16/i425&Display=hpfr&DefSeekPage=x
&SearchBack=ZyActionL&Back=ZyActionS&BackDesc=Results%20page&MaximumPages=1&ZyEntry=1&SeekPage=x&ZyP
URL# [accessed March 2020].

EPA. 2019a. Ethanol Waivers (E15 and E10). U.S. Environmental Protection Agency. <https://www.epa.gov/gasoline-standards/ethanol-waivers-e15-and-e10> [accessed June 2020]

EPA. 2019b. Renewable Fuel Standard Program. U.S. Environmental Protection Agency. <https://www.epa.gov/renewable-fuel-standard-program> [accessed June 2020]

EPA. 2019c. *Modifications to Fuel Regulations to Provide Flexibility for E15; Modifications to RFS RIN Market Regulations*. U.S. Environmental Protection Agency. <https://www.govinfo.gov/content/pkg/FR-2019-03-21/pdf/2019-05030.pdf> [accessed July 2019].

EPA. 2019d. Overview for Renewable Fuel Standard. U.S. Environmental Protection Agency. <https://www.epa.gov/renewable-fuel-standard-program/overview-renewable-fuel-standard> [accessed May 2020].

EPA. 2020. *Inventory of U.S. Greenhouse Gas Emissions and Sinks 1990–2018*. U.S. Environmental Protection Agency. <https://www.epa.gov/sites/production/files/2020-04/documents/us-ghg-inventory-2020-main-text.pdf> [accessed June 2020].

EWG. 2015. *Better Biofuels Ahead: The Road to Low-Carbon Fuels*. Environmental Working Group. https://static.ewg.org/reports/2015/better-biofuels-ahead/BetterBiofuelsAhead.pdf?_ga=2.110121731.709853254.1567808296-1187286386.1567808296 [accessed September 2019].

H.B. 2699. 2020. §196-42 State Support for Achieving Alternate Fuels Standards. Section 6. https://www.capitol.hawaii.gov/session2020/bills/HB2699_.HTM [accessed July 2019].

H.R. 6. 2005. Energy Policy Act of 2005. <https://www.congress.gov/109/plaws/publ58/PLAW-109publ58.pdf> [accessed March 2020].

H.R. 5037. 1978. National Energy Conservation Policy Act. <https://www.congress.gov/bill/95th-congress/house-bill/5037> [accessed April 2020].

IRS. 2019. *Credit for Renewable Electricity Production and Refined Coal Production, and Publication of Inflation Adjustment Factor and Reference Prices for Calendar Year 2019*. Internal Revenue Service, U.S. Department of the Treasury. https://www.novoco.com/sites/default/files/atoms/files/fedreg_060619.pdf [accessed July 2019].

IRS. 2020. About Form 8911, Alternative Fuel Vehicle Refueling Property Credit. Internal Revenue Service, U.S. Department of the Treasury. <https://www.irs.gov/forms-pubs/about-form-8911> [accessed May 2020].

LBNL. 2019. *U.S. Renewable Portfolio Standards: 2019 Annual Status Update*. Ernest Orlando Lawrence Berkeley National Laboratory. http://eta-publications.lbl.gov/sites/default/files/rps_annual_status_update-2019_edition.pdf [accessed September 2019].

Louisiana State Legislature. 2012. §4674: Minimum Ethanol and Bio-Diesel Requirements. <http://www.legis.la.gov/legis/law.aspx?d=206106> [accessed July 2019].

Minnesota Legislature. 2018. *2018 Minnesota Statutes, 239.77 Biodiesel Content Mandate*. https://www.revisor.mn.gov/statutes/2018/cite/239.77?keyword_type=all&keyword=biodiesel [accessed July 2019].

NCCETC. 2014a. Farm and Aquaculture Alternative Energy Loan. NC Clean Energy Technology Center. <https://programs.dsireusa.org/system/program/detail/2997> [accessed May 2020].

NCCETC. 2014b. Solar and Wind Permitting Laws. NC Clean Energy Technology Center. <https://programs.dsireusa.org/system/program/detail/3929> [accessed June 2020].

NCCETC. 2015a. Biomass Sales and Use Tax Exemption. NC Clean Energy Technology Center. <https://programs.dsireusa.org/system/program/detail/1952> [accessed May 2020].

NCCETC. 2015b. Alternative and Clean Energy Program. NC Clean Energy Technology Center. <https://programs.dsireusa.org/system/program/detail/3648> [accessed May 2020].

NCCETC. 2015c. Biomass Energy Tax Credit (Corporate). NC Clean Energy Technology Center. <https://programs.dsireusa.org/system/program/detail/1805> [accessed May 2020].

NCCETC. 2015d. Solar and Wind Energy Business Franchise Tax Exemption. NC Clean Energy Technology Center. <https://programs.dsireusa.org/system/program/detail/82> [accessed May 2020].

NCCETC. 2015e. Tax Exemption for Wind Energy Generation. NC Clean Energy Technology Center. <https://programs.dsireusa.org/system/program/detail/104> [accessed May 2020].

NCCETC. 2016a. Biomass Equipment & Materials Compensating Tax Deduction. NC Clean Energy Technology Center. <https://programs.dsireusa.org/system/program/detail/359> [accessed May 2020].

- NCCETC. 2016b. Biomass Producer or Collector Tax Credit. NC Clean Energy Technology Center. <https://programs.dsireusa.org/system/program/detail/5050> [accessed May 2020].
- NCCETC. 2016c. Agricultural Energy Loan Program. NC Clean Energy Technology Center. <https://programs.dsireusa.org/system/program/detail/5513> [accessed May 2020].
- NCCETC. 2017a. Commonwealth Organics-to-Energy Program. NC Clean Energy Technology Center. <https://programs.dsireusa.org/system/program/detail/5039> [accessed May 2020].
- NCCETC. 2017b. Agricultural Energy Program. NC Clean Energy Technology Center. <https://programs.dsireusa.org/system/program/detail/21861> [accessed May 2020].
- NCCETC. 2018a. Business Energy Investment Tax Credit (ITC). NC Clean Energy Technology Center. <http://programs.dsireusa.org/system/program/detail/658> [accessed August 2019].
- NCCETC. 2018b. Modified Accelerated Cost-Recovery System (MACRS). NC Clean Energy Technology Center. <https://programs.dsireusa.org/system/program/detail/676> [accessed July 2019].
- NCCETC. 2018c. Local Option – Special Energy Improvement Districts. NC Clean Energy Technology Center. <https://programs.dsireusa.org/system/program/detail/3554> [accessed September 2019].
- NCCETC. 2019a. Renewable Electricity Production Tax Credit (PTC), Database of State Incentives for Renewables and Efficiency® (DSIRE®). NC Clean Energy Technology Center. <https://programs.dsireusa.org/system/program/detail/734> [accessed June 2019].
- NCCETC. 2019b. Net Metering Policies, updated October 2019. NC Clean Energy Technology Center. https://s3.amazonaws.com/ncsolarcen-prod/wp-content/uploads/2019/10/DSIRE_Net_Metering_Oct2019.pptx [accessed May 2020].
- NCSL. 2020. State Renewable Portfolio Standards and Goals. National Conference of State Legislatures. <http://www.ncsl.org/research/energy/renewable-portfolio-standards.aspx> [accessed June 2020].
- New York State Senate Bill S4003. 2019. Establishes the Low Carbon Fuel Standard of 2019. <https://www.nysenate.gov/legislation/bills/2019/s4003> [accessed July 2019].
- NREL. 2008. *State of the States 2008: Renewable Energy Development and the Role of Policy*. National Renewable Energy Laboratory. <https://www.nrel.gov/docs/fy09osti/43021.pdf> [accessed July 2019].
- PV Magazine. 2019. Oregon Further Limits Use of Prime Farmland for Solar Development. <https://pv-magazine-usa.com/2019/05/24/oregon-further-limits-use-of-prime-farmland-for-solar-development/> [accessed July 2019].
- Reuters. 2019. When Harrow Met Solar: U.S. Land-Use Competition Heats Up. <https://af.reuters.com/article/commoditiesNews/idAFL8N1ZG5GC> [accessed July 2019].
- TitleMax. n.d. Gas Prices Through History. <https://www.titlemax.com/discovery-center/planes-trains-and-automobiles/average-gas-prices-through-history/> [accessed April 2020].
- Twitchell, Jeremy. 2019. A Review of State-Level Policies on Electrical Energy Storage. *Current Sustainable/Renewable Energy Reports* 6, 35-41. <https://link.springer.com/article/10.1007%2Fs40518-019-00128-1> [accessed April 2019].
- USDA. 2020a. Biomass Crop Assistance Program. U.S. Department of Agriculture. <https://www.fsa.usda.gov/programs-and-services/energy-programs/BCAP/index> [accessed May 2020].
- USDA. 2020b. Biorefinery, Renewable Chemical, and Biobased Product Manufacturing Assistance Program. U.S. Department of Agriculture. <https://www.rd.usda.gov/programs-services/biorefinery-renewable-chemical-and-biobased-product-manufacturing-assistance> [accessed May 2020].
- USDA. 2020c. Rural Energy for America Program – Renewable Energy Systems & Energy Efficiency Improvement Guarantee. U.S. Department of Agriculture. <https://www.rd.usda.gov/programs-services/rural-energy-america-program-renewable-energy-systems-energy-efficiency> [accessed May 2020].
- USDA. 2020d. *USDA Agriculture Innovation Agenda*. U.S. Department of Agriculture. <https://www.usda.gov/sites/default/files/documents/agriculture-innovation-agenda-vision-statement.pdf> [accessed February 2020].
- Washington Senate Bill 6508. 2006. Engrossed Substitute Senate Bill 6508. Page 3. <http://lawfilesexet.leg.wa.gov/biennium/2005-06/Pdf/Bills/Session%20Laws/Senate/6508-S.SL.pdf>

3. Bioelectricity

INTRODUCTION

This chapter describes the use of biomass to generate electricity and heat at both the individual *entity scale* for direct use by agricultural, forestry, paper, or other industrial businesses or rural households and at the *utility scale* to sell directly into power markets. Because electricity is a more common output than heat, this chapter uses the label “biomass power generation systems” for the technology. In the agricultural and forestry sectors, these systems can decrease energy costs, produce additional income from the sale of feedstocks and/or energy outputs, expand employment, help suppress wildfire risk, and reduce greenhouse gas (GHG) emissions.

Entity-scale systems generally have capacities of up to 10 megawatts (MW) of electricity and/or 30 million British thermal units (MMBtu) of heat and have project costs ranging from \$20,000 for small farm or forestry entity systems to \$50 million for utility-scale systems. There is size overlap between entity- and utility-scale systems, with the latter beginning at capacities of about 2 MW and being as large as 100 MW or more in the United States (Biomass Magazine, 2019). Approximately 53 percent of biomass and biogas (jointly bioenergy) electricity production is at the entity scale and 47 percent is at the utility scale (EIA, 2020a, table ES1.A).⁴⁰ On a combined basis, entity- and utility-scale bioenergy systems accounted for less than 2 percent of all U.S. electricity generation in November 2019, but 8 percent of total renewable electricity generation, including hydropower (EIA, 2020a, table ES1.A).

Feedstocks (i.e., fuel) for biomass power generation systems come from many agricultural sector and forestry sector sources, such as purpose-grown energy crops, wood and wood residues, agricultural crop residues, and manure from confined livestock operations.⁴¹ With respect to converting these biomass feedstocks into electricity and heat, the chapter emphasizes the most prevalent technology—combustion.⁴² The chapter also includes sections profiling gasification (an emerging technology that utilizes the same feedstocks as combustion) and anaerobic digestion technologies.⁴³

The six most important themes about biomass power generation technologies for the U.S. agricultural and forestry sectors are the following:

1. Combustion-based biomass power generation is a mature technology.
2. The economics and deployment of biomass power generation differ by region, with feedstock availability and costs, labor costs, regional market power prices, and State-level incentives being main drivers of these variations.
3. Nationwide, the growth of biomass power generation has been modest in recent years because there have not been substantial improvements in technology cost and performance. This contrasts with the growth trends of solar photovoltaic (PV) (see chapter 4) and wind energy systems (see chapter 5).
4. Unlike PV and wind energy systems, biomass power generation systems tend to provide predictable “baseload” power that does not change with weather conditions, season, or time of day.
5. By providing an additional feedstock market, biomass power generation systems can help promote forest health and decrease the damages associated with catastrophic wildfires.
6. State and Federal policies, including U.S. Department of Agriculture (USDA) policies, can significantly affect the economics of biomass power generation systems.

⁴⁰ Consumption of biomass and biogas electricity by commercial and industrial electricity end-use customers in the U.S. Energy Information Administration data is used as the proxy for entity scale.

⁴¹ There are additional biomass feedstocks from outside these sectors, including municipal solid waste.

⁴² Unless otherwise noted, all data in this chapter prior to the anaerobic digestion section apply to combustion technologies.

⁴³ Anaerobic digestion is a process by which bacteria operate in an oxygen-free environment to convert volatile solids in manure and other organic wastes into biogas and more stable organic compounds. The biogas can then be used to produce electricity and/or heat.

These six themes are explored in this chapter, which has the following sections:

- A characterization of how combustion and gasification technologies operate
- A summary of adoption costs, deployment, electricity prices, and policies by region
- A description of potential adoption impacts of the technologies on farm and forestry operations, rural households, rural communities, land uses, and the environment
- An explanation of typical ownership and financing models
- A profile of anaerobic digestion technologies
- An outlook on challenges to growth in biomass power generation

TECHNOLOGY CHARACTERIZATION

This section provides an overview of power and heat generating systems that use biomass feedstocks. The *combustion* and *gasification* systems reviewed can be designed to burn almost any biomass feedstock.⁴⁴ Because wood-based feedstocks are most commonly used in these systems, the descriptions below emphasize wood consumption.

Combustion Technology Overview

Wood has been used globally for cooking, heat, and light for thousands of years and was the primary feedstock people used to generate energy until the 19th century (EIA, 2020b). Combustion of wood to produce heat is a simple process, ranging from burning logs on a small open fire or in a domestic wood stove, to small and large pellet stoves and larger boilers that produce high-temperature water or steam. The output of the combustion process may be hot air, hot water, or steam, which can be ducted or piped and used for building heat, process heat (e.g., for a greenhouse or animal husbandry building), and hot water for domestic and on-farm use.

Larger systems produce (1) steam that drives a turbine, which, in turn, drives a generator that produces electricity; or (2) high-temperature hot water that drives an Organic Rankine Cycle (ORC) turbine to produce electricity.^{45,46}

Combustion Technology Configuration and Operation

Generally, biomass combustion systems include the following components:

- **Feedstock storage:** The size and type of storage (e.g., silos, covered storage, open piles) depend on feedstock availability, distance of the system from the feedstock source, overall size of the combustion system, and requirements to protect feedstock material from the elements. Storage capacity must allow for periods when biomass may be unavailable (e.g., winter) or hard to collect and transport (e.g., during “mud season”).
- **Feedstock preparation and processing:** Depending on the form of biomass (e.g., whole logs, chips, pellets, bales), this part of the system may include chipping, shredding, screening, and drying equipment.
- **Furnace/Boiler:** In addition to a furnace/boiler, this unit will generally include a feedwater system, air pollution control system for equipment exhausts, and ash handling and storage system.
- **Turbine-Generator:** For example, packaged steam or ORC turbine, generator, and condenser.

⁴⁴ Gasification systems are more susceptible to problems related to variations in feedstock size, quality, and moisture content than combustion systems. Among combustion systems, stoker and travelling grate boilers are less susceptible to these problems.

⁴⁵ For more information on steam and ORC technologies, see EPA, 2012a, p. 3.

⁴⁶ While producing steam or high-temperature hot water can be used to generate electricity, excess steam or hot water can also (but is not required to) be directed to facility heat and other uses in a combined heat and power configuration.

Exhibit 3-1 depicts these four basic components.

EXHIBIT 3-1: Combustion/Steam Turbine Biomass Power Generation Block Diagram

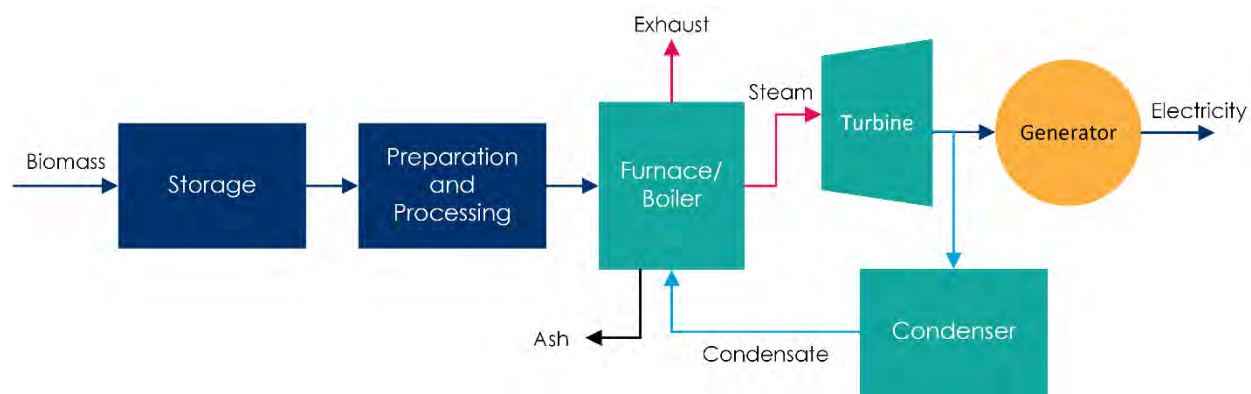

Source: ICF, adapted from NIBS, 2016.

There are several boiler types, including stoker, travelling grate, circulating fluidized bed, and bubbling bed, that convert the heat from combustion of wood to hot water and steam. For smaller on-farm biomass combustion systems, stoker and, to a lesser extent, travelling grate boilers tend to be the least complicated and least expensive to install and operate. Some factors influencing the type of boiler used in individual biomass power generation systems are:

- Feedstock characteristics⁴⁷
- Desired electric generation capacity
- Temperature, pressure, and efficiency requirements
- Environmental constraints (e.g., permitting related to air emissions from combustion and/or wastewater limits)
- Specialization of required labor skills
- Capital cost

Combustion Technology Examples

One of the largest utility-scale biomass plants in the United States (Biomass Magazine, 2019) is the Deerhaven Renewable Energy Center in Gainesville, FL, which has a capacity of 102.5 MW (Power Technology, 2020).

Another large combustion power generation system is the Wadham Energy project in Williams, CA, which has a capacity of 26.5 MW and burns rice hulls to produce electricity (shown in *exhibit 3-3*). In addition to creating revenues from the sale of electricity, the combustion of rice hulls helps solve a rice hull disposal problem as the mills serving the project produce several hundred thousand tons of hulls each year (Biomass Power Association, 2020).

EXHIBIT 3-2: Example Wood Chips Used for Direct Combustion Plants



Image Source: DOE, 2012.

⁴⁷ For example, fluidized bed boilers tend to require that pieces of feedstock be within narrow size ranges, whereas stoker boiler systems can accept feedstocks that vary more in size.

At larger capacities, woody biomass has been co-fired with coal, as in the Drax Power Station in the United Kingdom.⁴⁸ The Drax plant has a total generating capacity of 3,960 MW, with four of its six boilers having been converted to using wood pellets as the process fuel (Power Stations of the UK, 2020). Co-firing biomass with coal, as in the Drax plant, can substantially reduce GHG emissions compared to coal-only power plants.⁴⁹

Gasification Technology Overview

Gasification is the process of producing what is commonly called *synthesis gas* (other common names are “syngas” and “producer gas”) by heating purpose-grown crops, wood, or agricultural wastes with less oxygen than needed for complete combustion. Gasification processes have been used for more than 180 years and were commonly applied into the 20th century to produce town gas from coal and peat before natural gas became abundantly available (SERI, 1979, pp. II-3 – II-4). While rare on U.S. farms today, small-scale gasification systems suitable for on-farm use have been developed along with utility-scale systems.

Gasification processes have been used for more than 180 years and were commonly applied into the 20th century to produce town gas from coal and peat before natural gas became abundantly available (SERI, 1979, pp. II-3 – II-4). While rare on U.S. farms today, small-scale gasification systems suitable for on-farm use have been developed along with utility-scale systems.

Gasification Technology Configuration and Operation

Chemically, gasification is a process that converts carbonaceous materials into gases such as carbon monoxide (CO), hydrogen (H₂), and carbon dioxide (CO₂), as well as smaller quantities of methane, nitrogen, and other gases by reacting the feedstock at high temperature in a low-oxygen environment. Collectively, these gases are the syngas. Prior to use in generating electricity, the syngas must be cleaned to remove particulate and gaseous contaminants. The cleaned syngas is compressed and used in reciprocating internal combustion engines, combustion turbine generators, microturbines, or fuel cells to produce electricity. Biochar and ash are byproducts of this process. *Exhibit 3-4* describes the process.⁵⁰

EXHIBIT 3-4: Gasifier Biomass Power Generation Block Diagram

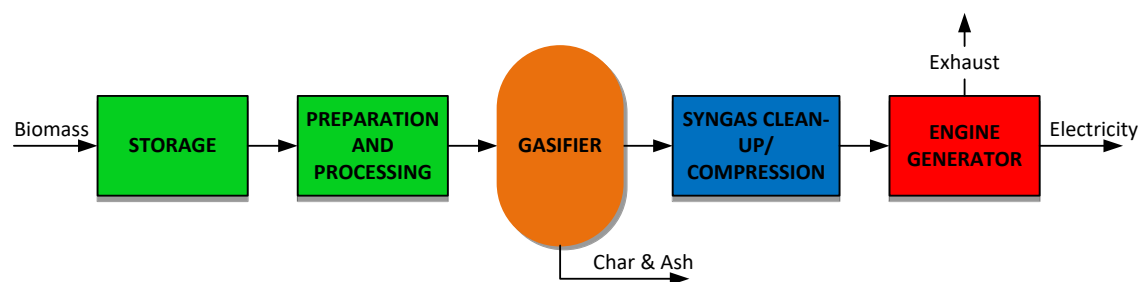

Source: ICF.

A biomass gasification system will have similar feedstock storage and preparation requirements to that of a biomass combustion system. Distinct components are the following:

⁴⁸ Co-firing refers to combusting two or more different fuels at the same time in a power plant.

⁴⁹ The extent of GHG reductions depends on both the types of fuels that are co-fired and whether the biomass used is considered carbon-neutral. See the Adoption Benefits section of this chapter for more information on the carbon neutrality of biomass power generation.

⁵⁰ Biochar (charred biomass) produced from gasification is carbon rich and can be used as a soil supplement. Because it is extremely porous, biochar can help retain water in sandy soils and reduce leaching of nutrients and fertilizers. While the biochar market is growing, it is still small and rarely has a large effect on biomass power generation system economics.

EXHIBIT 3-3: Wadham Energy (Rice Hull-Fired) Direct Combustion Power Plant



Image Source: Biomass Power Association, 2020.

- Gasifier: The gasifier may include equipment for oxygen generation; feedstock feeder; and handling gasifier ash, slag, and char.
- Syngas clean-up: Components typically include equipment for tar cracking, particulate removal, heat recovery/cooling/steam generation, and gaseous cleanup, which may remove hydrogen sulfide, CO₂, and water.
- Generator
 - Engine Generator: Generators include equipment for gas compression, internal combustion, engine cooling, and emission controls for nitrogen oxides, and may also include technologies to control combustion air temperature. Hot exhaust gases from the internal combustion engine and hot engine jacket coolant can be routed through a waste heat boiler or heat exchanger to produce steam or hot water for building heat and process uses.
 - Combustion Turbine Generator: This is an alternative technology to an engine generator. It will include gas compression, a combustion turbine generator (often referred to as a “gas turbine generator”), and emissions controls for nitrogen oxides and possibly CO. Hot exhaust gases from the combustion turbine can be routed to a heat recovery generator to produce steam, which, in turn, can power a steam turbine to produce additional electricity or be used for industrial processes.
 - Microturbine Generator: Another alternative to an engine generator is a microturbine generator. This will include a gas compression technology, a microturbine (small-scale combustion) generator, and emissions controls for nitrogen oxides. Hot exhaust gases from the turbine can be routed to a heat recovery steam generator to produce steam or hot water, which, in turn, can be used to provide building heat, chilled water, or process hot water.⁵¹

Gasification Technology Examples

Currently, there does not appear to be any operational gasification to power facilities at utility scale in the United States. However, there are several small biomass gasification systems at least in the planning or development stages (PRWeb, 2017).

Outside the United States, Danish Oil and Natural Gas developed the 6-MW Pyrenee gasification system in Denmark in 2011 that was fueled by straw, manure fibers, and other residues (ETIP, 2020; IEA, 2019, p. 23). That demonstration system proved that an electricity-producing gasification system could

Adoption of Small-Scale Biomass Gasification Technology

Despite recent advances in modular gasification technologies, there are currently few installed biomass gasifiers on U.S. farms. One gasification pilot is the Packaged Gasification CHP Project at Biodico.

Biodico is a sustainable biorefinery operator working in partnership with Redrock Ranch in Five Points, CA, to study bioenergy solutions. With assistance from a California Energy Commission grant, the company installed a biomass gasification CHP system in 2016. The project utilizes agricultural byproducts such as inedible seed meal from biodiesel production and methane from a separate anaerobic digestion system. The gasifier system has approximately 18 kW of capacity and converts biomass inputs into electricity and biochar (All Power Labs, 2020a, All Power Labs, 2020b).



Image Source: All Power Labs, 2020a.

⁵¹ Microturbines can be available for up to 1,000 kilowatts (kW) (equal to 1 MW) in electrical generating capacity, although they are often smaller in capacity (EPA, 2017a, p. 5-1).

be technically successful. However, it ceased operation in 2014 due to lack of market interest in this technology (Copenhagen Post, 2014). There are three multi-megawatt scale gasification combined heat and power (CHP) plants operating in Denmark that use wood feedstocks (IEA, 2019, p. 16).

CURRENT LEVEL AND COST OF ADOPTION AND REGIONAL DISTINCTIONS

After expanding by approximately 2 percent per year from 49,748,000 megawatt-hours (MWh) in 2001 to 63,989,000 MWh in 2014, overall electricity production from biomass and biogas (jointly bioenergy) feedstocks has declined slightly in the United States in recent years (EIA, 2020c). Bioenergy production is primarily from wood and wood-derived biomass (68 percent of total), with smaller shares from landfill gas (17 percent), biogenic municipal solid waste (10 percent), and other waste biomass (4 percent) (EIA, 2020a, table 1.1.A).

Over the period from 2014 to 2018, net generation from bioenergy feedstocks (in all sectors) decreased 2,088,000 MWh, or 3 percent in aggregate to 61,901,000 MWh (DOE, 2020, p. 78). Annual production from bioenergy declined further to 58,412,000 MWh in 2019 (EIA, 2020a, table 1.1.A).⁵³

Bioenergy power generation capacity in 2018 was 15,563 MW_{AC} (DOE, 2020, p. 78). Recent trends in bioenergy electricity capacity (MW) and annual production (gigawatt-hours [GWh])⁵⁴ are shown in exhibit 3-5.

Nationally and regionally, four main drivers affect adoption patterns for biomass combustion technologies. These are:

1. Feedstock resource
2. Capital and operating costs
3. Retail and wholesale power prices
4. Policies for financial incentives

The importance of each driver on technology deployment is described below. The data show that while combustion of wood, purpose-grown crops, and agricultural waste to generate heat and power is technically feasible in many parts of the United States, deployed biomass systems are concentrated in the Southeast and California due to the combination of more widely available biomass resources (in both regions), lower capital costs (in the Southeast), and strong incentive policies and high power prices (in California).

EXHIBIT 3-5: U.S. Bioenergy Power Generation Capacity and Annual Production Trends

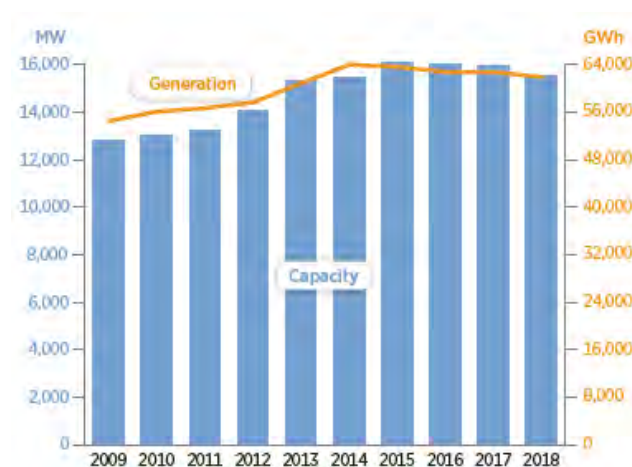

Source: DOE, 2020, p. 78 (capacity is on the left axis and annual electricity production is on the right axis).⁵²

⁵² In this exhibit, the relationship between the generation line and the capacity bars is determined by the average "capacity factor" of biomass systems in each year. Capacity factor measures the annual productivity of an electricity generating system compared to its maximum potential. A capacity factor of 100 percent indicates a system that is producing power at its maximum rated capacity every hour of the year. The formula for capacity factor is annual electricity output (MWh) divided by the product of rated capacity (MW) and the number of hours in the year. As capacity factors decrease, the generation line in this exhibit lowers in relation to the capacity bars.

⁵³ Data for January 2020.

⁵⁴ 1 gigawatt-hour (GWh) is equal to 1,000 MWh or 1,000,000 kilowatt-hours (kWh).

Feedstock Resource

Major feedstocks currently used for biomass power generation include:

- Wood and waste wood
- Agricultural wastes, including straw, orchard prunings, bagasse,⁵⁵ dried animal manure, corn stover, and rice husks
- Purpose-grown energy crops, including Miscanthus and coppiced willow⁵⁶

Wet agricultural wastes, such as animal manure, are commonly converted to biogas using anaerobic digestion before being combusted.

The feasibility of biomass systems largely depends on the location, quantity, and price of feedstocks. For this reason, farm and forestry entities with control over reliable sources of biomass (usually on-site) have cost advantages over similar operations that must negotiate long-term agreements to purchase biomass from elsewhere and pay to transport it (NREL, 2009, p. 5).

As shown in *exhibit 3-6*, the majority of power from bioenergy in the United States is generated from wood and wood-derived feedstocks, including black liquor (which is a byproduct of pulping processes)(EIA, 2017).

EXHIBIT 3-6: U.S. Electricity Generation by Fuel Type

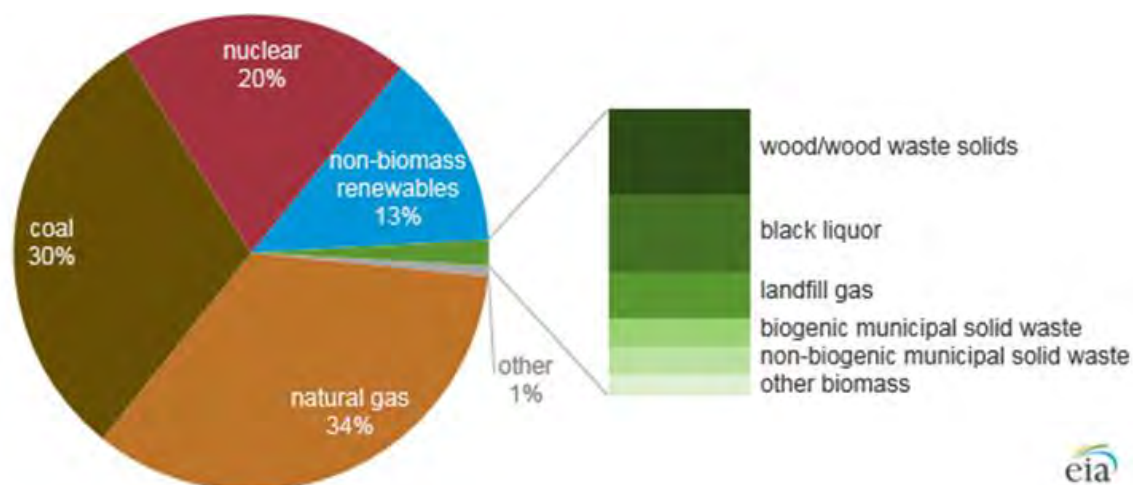

Source: EIA, 2017.

Exhibit 3-7 breaks down feedstock types for biomass power generation systems of 1 MW and larger in capacity (DOE, 2015). The chart shows that the prevalence of wood-based feedstocks occurs at system sizes of 10 MW and greater. This is due to wood sources' abundant geographic availability, relatively high energy density, ease of storage and re-use from storage, and year-round availability (unlike seasonal energy crops, such as switchgrass or Miscanthus).

⁵⁵ Bagasse is plant residue following extraction of a commercial product, such as from sugarcane or grapes.

⁵⁶ See chapter 8 for more information on purpose-grown forestry energy crops (poplar and willow) and agricultural energy crops (Miscanthus and switchgrass).

EXHIBIT 3-7: Cumulative Capacity of Bioenergy Power Generation Systems in the United States by Individual Project Size and Feedstock Type

Credit: National Renewable Energy Laboratory

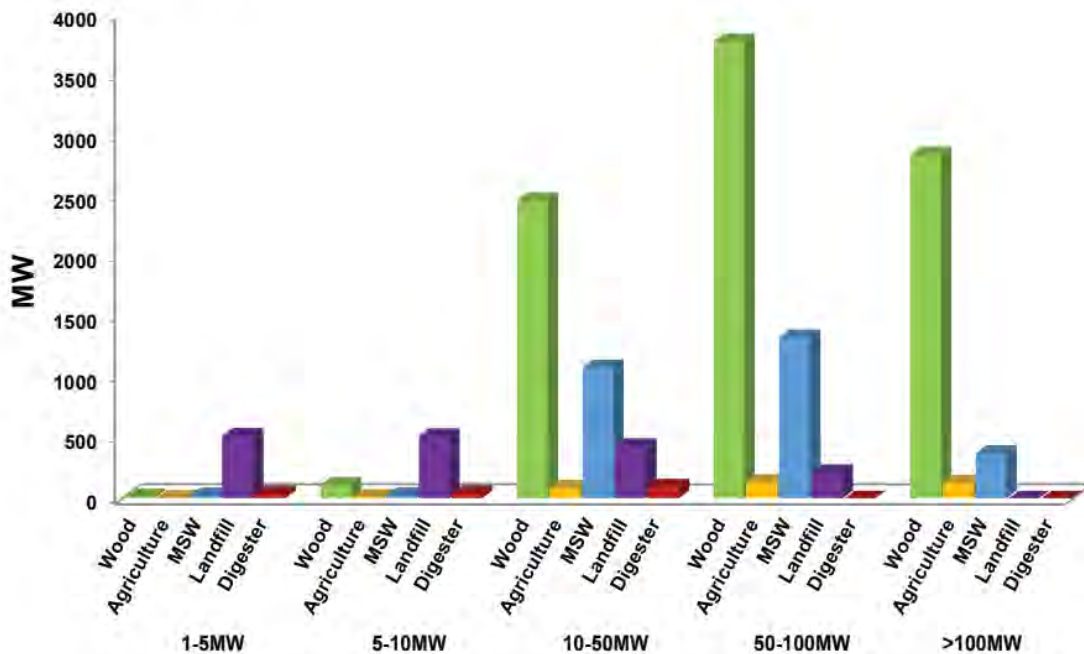

Source: DOE, 2015, p. 4.

Feedstock availability varies across states. *Exhibit 3-8* shows total solid biomass resources by county, which includes "crop residues, forest and primary mill residues, secondary mill residues, and urban wood waste" (NREL, 2014a). The high density of biomass resources in Midwestern States, such as Illinois and Iowa, is largely due to crop residues, which are not highly utilized in biomass power production at present (NREL, 2014b). The ample forest resources in Southeastern States, as well as parts of the Northwest and in Maine, make woody biomass more available in those areas (NREL, 2014b).⁵⁷

⁵⁷ More than 147 million trees have died due to causes such as drought and bark beetle infestations since 2010 in California alone (USDA, 2019a), and these trees represent a potential source of low-cost woody biomass.

EXHIBIT 3-8: Solid Biomass Resources by County

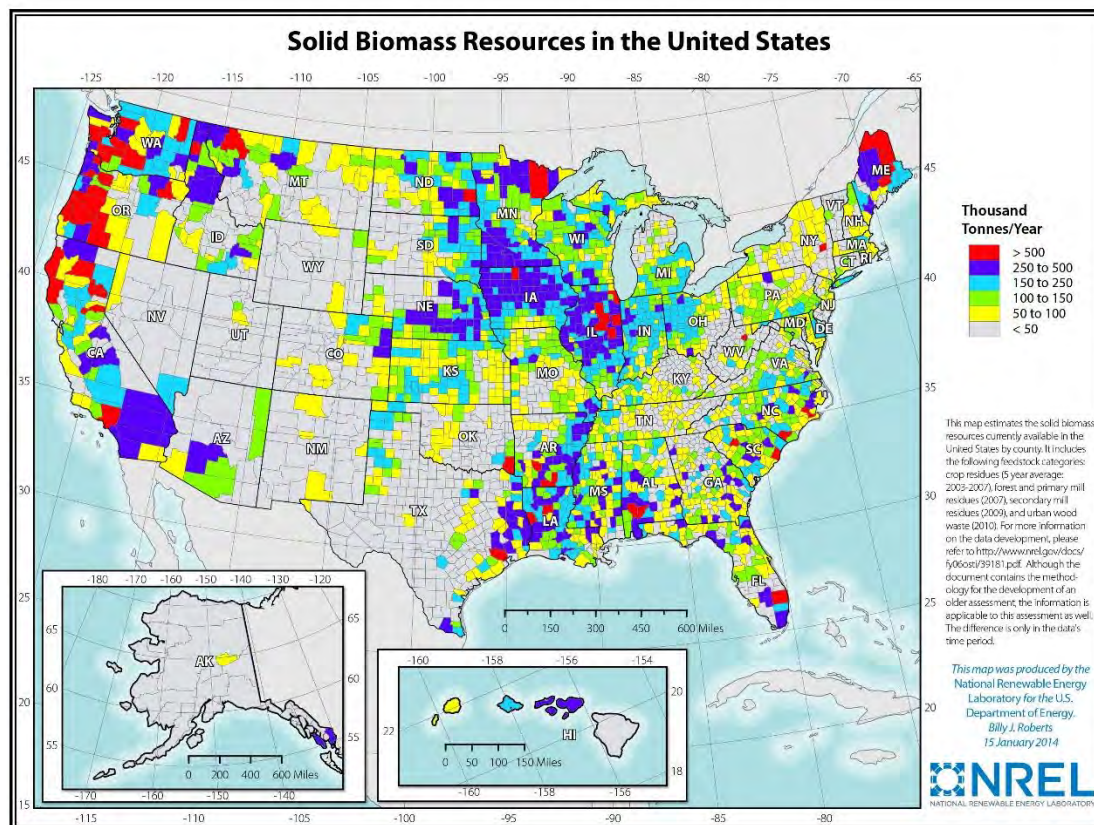

Source: NREL, 2014a.

Capital and Operating Costs

Adoption costs for biomass power generation systems vary widely. Different configurations, feedstocks, labor costs, and clean-up requirements greatly affect system economics and make it difficult to calculate one precise “installed cost” that is broadly applicable. The next three sub-sections describe system capital costs, feedstock and non-feedstock operations and maintenance (O&M) costs, and the levelized cost of energy, which is a metric incorporating lifetime system costs and performance.

Because biomass combustion is a much more mature and widely used technology than biomass gasification, there is greater breadth and precision to the cost data provided for combustion technologies. Cost data for anaerobic digestion systems are summarized in a section dedicated to that technology later in the chapter.

National Average Capital Costs

Capital costs (also called “installed costs”) for entity- and utility-scale biomass power generation systems include the full cost of system design, engineering, and construction, as well as the costs of purchasing equipment, permitting, and financing the component systems before accounting for any financial incentives.⁵⁸

⁵⁸ Where available, capital-based incentives such as the investment tax credit for biomass CHP systems can reduce net capital costs below the gross cost levels described in this section.

Exhibit 3-9 provides capital cost ranges for combustion and gasification power generation systems. Gasification is a much less widely used technology and has higher capital costs.

In a CHP configuration that produces both electricity and thermal outputs, capital costs can be up to \$2,500 per kilowatt (kW) higher than for systems generating only electricity, like those in exhibit 3-9, when the complexity of integrating thermal outputs with building systems is high, although the incremental cost of CHP is often much lower (IRENA, 2012, p. 33).⁶¹

Biomass combustion systems that only produce heat (and not electricity) have fewer components than electricity generating systems and far fewer than CHP systems. The great majority of their capital costs are for the combustion system (boiler or gasifier), feedstock delivery and handling system, and thermal recovery. The technology for such heat-only systems is mature, and its costs have not changed significantly in recent years. Capital costs for biomass wood heat-only systems are estimated at between \$323/kW and \$827/kW, with an average value of \$575/kW (NREL, 2016).⁶² Annual O&M costs for these heat-only systems are estimated at \$98/kW (NREL, 2016).

Regional Distinctions in Capital Costs

Capital costs for biomass power generation systems differ by region due to differences in factors including feedstock cost, climate, seismic design, location accessibility, wage rates and productivity, permitting, and infrastructure upgrade costs (EIA, 2016a, pp. 13-3 – 13-4).⁶³

For example, plants located in cold climates may need to be built in enclosed structures for the boilers to avoid freezing, and plants in remote locations typically have higher than average transportation costs (EIA, 2016a, p. 13-4). High population densities and high costs of living are generally correlated with higher labor costs for biomass power generation, which can add costs for systems in the Northeast and California, for example (EIA, 2016a, p. 13-4).

Exhibit 3-10 displays average capital costs in dollars per kilowatt for a utility-scale biomass combustion plant of 50 MW across 12 States, assuming a national average cost of \$4,985/kW (EIA, 2016a, p. 13-3).⁶⁴ The five States with the lowest capital costs are all located in the South Census Region.

EXHIBIT 3-9: Biomass Power Generation System Capital Costs (Pre-Incentive)

Biomass Generation Technology	Capital Cost (\$/kW)
Combustion	\$2,000 to \$5,000 ⁵⁹
Gasification	\$5,550 to \$15,000 ⁶⁰

Sources: CPC, 2019; NREL, 2019; Lazard, 2017; EIA, 2016a; NIBS, 2016; USDA, 2014a; Black & Veatch, 2013.

⁵⁹ The cost range is a summary from five sources: (1) investment bank Lazard estimated capital costs for a 10-MW biomass power generation system at \$1,700 to \$4,000/kW (Lazard, 2017, p. 19); (2) National Institute of Building Sciences (NIBS) estimated capital costs for a 5-MW to 25-MW system at \$3,000 to \$5,000/kW, and small-scale systems at \$3,000 to \$4,000/kW (NIBS, 2016); (3) National Renewable Energy Laboratory (NREL) estimated capital costs at \$3,990/kW (NREL, 2019); (4) USDA estimated capital costs for a 50-MW system at \$3,860/kW (USDA, 2014a, p. 8); and (5) U.S. Energy Information Administration (EIA) estimated capital costs for a 50-MW system at \$4,985/kW (EIA, 2016a, p. 7).

⁶⁰ A manufacturer of a 165-kW modular biomass gasification system identifies an equipment-only cost of \$6,900/kW and an estimated total capital cost of \$12,000 to \$15,000/kW (CPC, 2019). A 2013 study estimates the capital cost of a larger 3,000-kW (3-MW) biomass gasification system using agricultural and forest residues as between \$5,000/kW and \$7,500/kW, or \$5,550 to \$8,325 in current dollars (Black & Veatch, 2013, p. 4-4). Capital costs were converted to 2020 dollars using the U.S. Bureau of Labor Statistics (BLS) Consumer Price Index Inflation Calculator (<https://data.bls.gov/cgi-bin/cpicalc.pl>), which increased prices by an aggregate 11 percent between April 2013 and January 2020.

⁶¹ The choice of "prime mover" technology in a CHP project (e.g., internal combustion engine, combustion turbine, steam turbine, microturbine, or fuel cell) will substantially affect system cost and performance. For more information, see EPA, 2017a.

⁶² Costs for "biomass wood heat (were) converted from thermal energy capacity (Btu/hr)" (NREL, 2016).

⁶³ For biomass combustion systems at industrial facilities, additional capital cost factors related to integrating any thermal outputs (e.g., heat) directly into industrial processes apply.

⁶⁴ The capital cost estimates were based on a 50-MW biomass bubbling fluidized bed facility utilizing approximately 2,000 tons per day of wood. For States with capital costs listed for multiple intrastate locations, the arithmetic mean of those locations is displayed on the chart.

EXHIBIT 3-10: Utility-Scale Biomass Power Generation System Capital Costs in Selected States

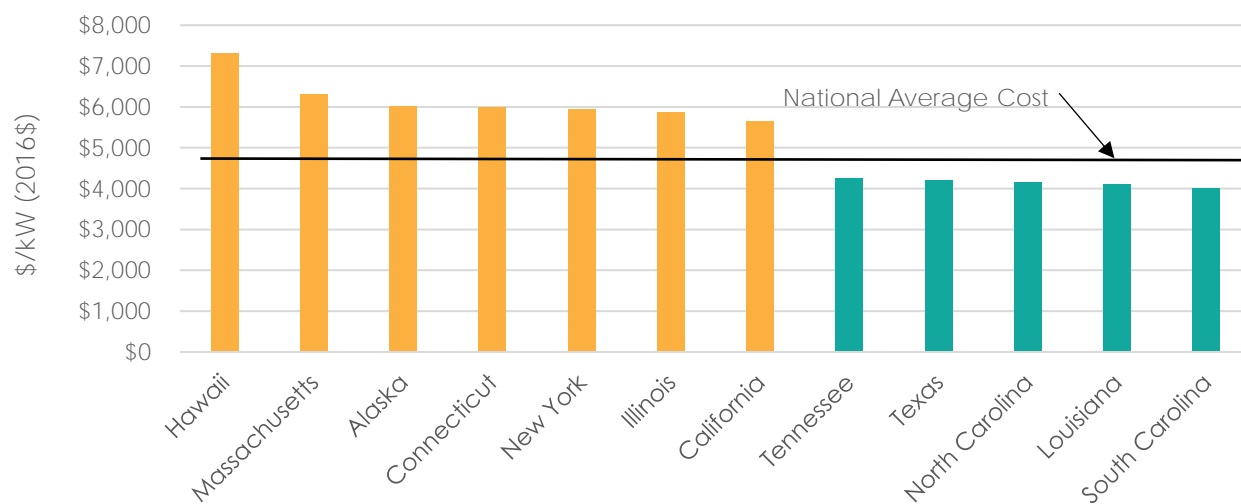

Source: Based on EIA, 2016a, pp. A21–A22.

Operations and Maintenance (O&M) Costs

O&M costs include fixed costs, non-feedstock variable costs, and variable feedstock costs. Fixed O&M costs are typically presented as an annual dollar amount per kW of capacity, while variable O&M costs depend on the quantity of energy produced and are typically presented on a \$/MWh or \$/kWh basis.

Non-Feedstock O&M

Fixed O&M costs consist of required daily labor for system operations, scheduled maintenance, routine component and equipment replacement, and other recurring costs, such as insurance, taxes, and land lease payments. Variable, non-feedstock O&M costs vary with system output. They include costs for ash disposal, purchased services required to operate the plant (e.g., water from public or private suppliers), and any unplanned equipment replacement or servicing costs driven by system use.

EXHIBIT 3-11: Utility-Scale Biomass Power Generation O&M Costs (not including feedstock costs)

Biomass Power Generation Technology	Fixed O&M Costs (\$/kW-year)	Variable, Non-Fuel O&M Costs (\$/MWh)
Combustion	\$50 to \$110 ⁶⁵	\$4.20 – \$10.00 ⁶⁶

Sources: Lazard, 2017, p. 19; EIA, 2016a, p. 13-4; USDA, 2014a, p. 8.

Exhibit 3-11 presents a range of fixed and variable, non-fuel O&M costs for the first year of operation of biomass power generation systems using combustion technologies.^{67,68} These O&M costs typically rise each year with general price inflation.

⁶⁵ Lazard estimates fixed O&M costs at \$50/kW-year for a 10-MW biomass power generation system, EIA estimates fixed O&M at \$110/kW-year for a 50-MW system, and USDA estimates fixed O&M at \$100.50/kW-year for a 50-MW system.

⁶⁶ Lazard estimates variable, non-fuel O&M costs at \$10/MWh for a 10-MW biomass system, EIA estimates such costs at \$4.20/MWh for a 50-MW system, and USDA estimates those costs at \$5/MWh for a 50-MW system.

⁶⁷ These O&M costs are likely higher for small to mid-sized, entity-scale systems (NIBS, 2016). This is often because the labor requirements for a plant are similar even as the system size grows.

⁶⁸ Fixed O&M costs for biomass systems using gasifiers tend to be higher than for systems using combustion, while variable, non-feedstock costs are similar between the two technologies (IRENA, 2018, p. 131).

From *Exhibit 3-11*, a 10-MW power plant would have annual O&M costs (before feedstocks) in its first year of operation of approximately \$1.3 million.⁶⁹

Feedstock O&M

Feedstock costs are typically the most significant ongoing operational cost of biomass power generation systems. Feedstocks can account for 40 percent to 50 percent of a system's long-term cost of producing electricity (IRENA, 2012, p. 27).⁷⁰

Exhibit 3-12 displays base case projections from the U.S. Department of Energy's *Billion-Ton Report* of potential biomass resources as a function of price (DOE, 2016a). At lower prices, agricultural residues, forestry products, and waste biomass make up the majority of supply, while energy crops tend to become viable in the future at prices of approximately \$50 per dry ton and above (DOE, 2016a, page xxv).

EXHIBIT 3-12: Stepwise Feedstock Supply Curves (at prices up to \$90/dry ton)

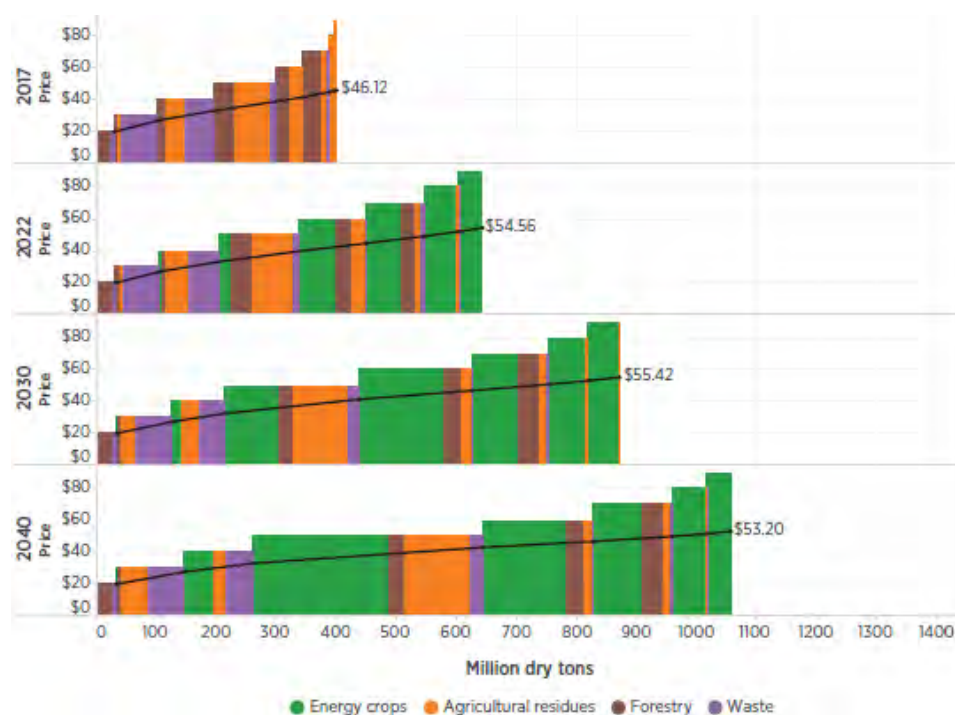

Source: DOE, 2016a, p. xxv.

For more detailed descriptions of biomass feedstocks and their costs, see chapters 8 and 9.

⁶⁹ The calculation is as follows: For annual fixed O&M cost, 10-MW capacity (or 10,000 kW) x \$80/kW-year O&M cost (midpoint of range in table) = \$800,000. For annual variable, non-feedstock O&M cost, 10-MW capacity x 82.5 percent capacity factor (percentage of time throughout the year that the system is running at capacity) x 8,760 hours in a non-leap year x O&M cost at midpoint of range in table (or \$7.10/MWh) = \$513,117. Fixed + Non-feedstock variable O&M cost = \$800,000 + \$513,117 = \$1,313,117/year. The midpoint of the capacity factor range of 80 percent to 85 percent in the Lazard study was used for this calculation (Lazard, 2017, p. 19).

⁷⁰ In some cases, feedstock costs can be negative. That occurs when the feedstock (e.g., urban wood waste or municipal solid waste) would otherwise incur disposal costs (also called "tipping fees") if not combusted or gasified in a biomass power generation system.

Levelized Cost of Energy (LCOE)

Exhibit 3-13 summarizes the LCOE⁷¹ range and key assumptions for a 10-MW entity- or utility-scale combustion biomass system with a 25-year facility life. Smaller scale biomass systems have an LCOE of \$0.08 to \$0.15/kWh (NIBS, 2016).

While the LCOE for biomass systems is high in comparison to utility-scale wind energy and PV systems, biomass systems have an advantage in providing “baseload” electricity as opposed to the more variable electricity provided by wind and solar resources.⁷² Biomass systems also have the potential to secure additional revenue streams through the sale of thermal outputs (e.g., hot water or steam) and, in limited cases, byproducts such as biochar.

Grid (Retail and Wholesale) Power Prices

Retail electricity prices are those paid by end-users such as farms, forestry businesses, and rural households, while wholesale prices are those paid by power resellers prior to delivery of electricity to end-users. Both types of prices are important to the regional pattern of biomass power generation, with retail prices pertaining to entity-scale systems and wholesale prices to utility-scale systems.

For entity-scale systems connected to an end-user's utility meters, biomass electricity output reduces the amount of retail power that is consumed from the utility, thereby reducing the utility bill. In the simplest example, if a farm uses a total of 100,000 kWh of power in a month, but produces 80,000 kWh of electricity from biomass that month, then it consumes 20,000 kWh of utility power on a net basis, and its utility bill will be proportionally less than if it had purchased all 100,000 kWh from the utility.⁷³

The key question from this example is “What is the 80,000-kWh decline in utility consumption worth?” In some parts of the United States, retail electricity can cost \$0.08/kWh (or less), and in other regions, it can cost \$0.17/kWh or more. At the low end of that range, the biomass power output is worth \$6,400/month. At the high end, it is worth \$13,600/month. The reason for the difference is that utility rates vary, as can be seen in exhibit 3-14. In that exhibit, States with darker colors, such as Alaska, California, and New York, have higher average retail electricity prices.

Switching to the wholesale electricity prices relevant to utility-scale biomass power generation systems, average on-peak prices ranged in major regional U.S. markets from approximately \$0.03/kWh to \$0.05/kWh in 2018, with the lowest prices occurring in the Northwest and the highest occurring in New England, as shown in exhibit 3-15 (EIA, 2020d).⁷⁴ In 2019, the prices were in a narrower range among the regions.

EXHIBIT 3-13: Estimated LCOE and Key Assumptions for 10-MW Biomass Combustion Power Generation System

Biomass System Characteristic	Metric
LCOE	\$0.055 – \$0.114/kWh
Heat Rate (per kWh)	14,500 Btu
Capacity Factor	80 percent – 85 percent
Feedstock Price	\$1.00 – \$2.00/MMBtu

Source: Lazard, 2017, p. 19.

⁷¹ LCOE is a summary measure of lifetime costs of building and operating electricity generation systems per unit of output (\$/kWh). See chapter 4 for an expanded definition of LCOE.

⁷² Baseload electricity can be generated at consistent levels over long periods. If a biomass system has a reliable, long-term feedstock supply and operational plan, it should be able to serve as a baseload power plant. In contrast, without a means of storing electricity, power from wind and PV systems can vary minute to minute with the availability of wind and sunlight. Therefore, it is also instructive to compare the biomass system LCOE to the LCOE of \$0.082/kWh for PV combined with battery storage (Lazard, 2017, p. 2).

⁷³ There are complexities in certain utility markets that pertain to hourly and sub-hourly patterns of electricity consumption and biomass power production, and utility rules for netting and compensating the difference (e.g., “net metering”). The presence of peak demand and fixed monthly utility charges also will complicate the example. However, in most locations, the directional basics of this example hold true.

⁷⁴ Prices are from the Intercontinental Exchange (ICE) and are the weighted average, by trading volume, of daily prices for the following four power trading hubs and pricing products: Mid-Columbia Peak (Northwest), Palo Verde Peak (Southwest), PJM Western Hub Real-Time Peak (Mid-Atlantic/Ohio Valley), and NEPOOL Massachusetts Hub Day-Ahead Peak (New England). To review

EXHIBIT 3-14: Average Retail Electricity Prices by State (\$/kWh)

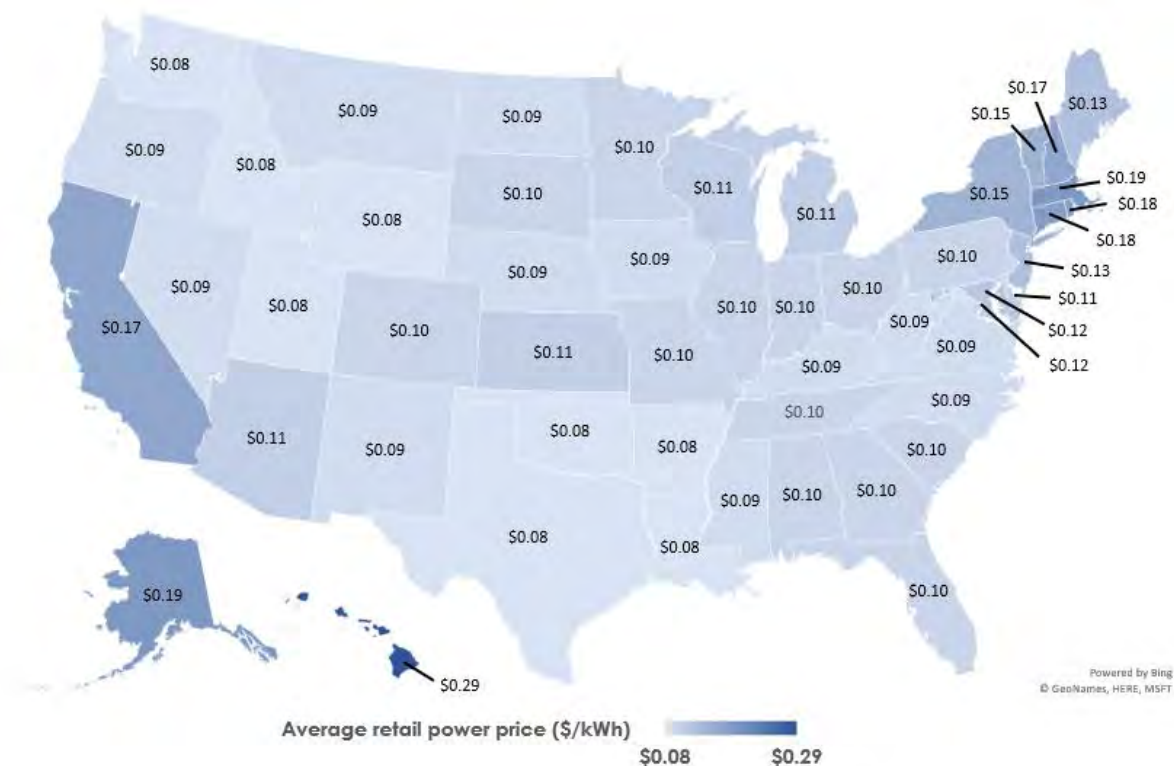

Source: Based on EIA, 2019a.

EXHIBIT 3-15: Average On-Peak Wholesale Electricity Prices for Selected Market Regions (\$/kWh)

Power Trading Hub and Price Type	U.S. Region	2017 Price	2018 Price	2019 Price
Mid-Columbia Peak	Northwest	\$0.025	\$0.032	\$0.040
Palo Verde Peak	Southwest	\$0.036	\$0.050	\$0.033
PJM Western Hub Real-Time Peak	Mid-Atlantic/Ohio Valley	\$0.037	\$0.045	\$0.035
NEPOOL Massachusetts Hub Day-Ahead Peak	New England	\$0.037	\$0.052	\$0.037

Source: Based on EIA, 2020d.

Policies for Financial Incentives

Overview

Federal incentives uniformly available across all 50 States have been key to the increased adoption of renewable energy systems over the past decade. Many of these incentives (e.g., the investment tax credit [ITC] for biomass and conventionally fueled CHP, the production tax credit [PTC] for biomass systems, accelerated depreciation, USDA programs) still exist. However, if the PTC expires at the end of 2020 per current legislation, State-level incentives, as well as certain local government or utility-specific incentives, are likely to play increasingly important roles in shaping regional adoption patterns.

historical ICE pricing data, see EIA, 2020d. On-peak periods are defined within each region and typically cover morning to mid/late evening hours on business days, while off-peak periods cover other times (late evening through early morning during the business week and all day on weekends and holidays) and typically have lower average prices than on-peak periods (EIA, 2020e).

Some States have no special incentives, while others offer several different types of incentives. Compensation policies (called “net metering”) for excess electricity production from biomass power generation systems (above what is used on-site at a business or household) also differ by State.⁷⁵

Federal Incentive Policies

Federal Tax Credits

There are three types of Federal tax incentives in place for biomass power generation systems: ITC, PTC, and accelerated depreciation. The Federal ITC provides a tax benefit to offset 10 percent of the capital cost of eligible biomass (and fossil fuel) CHP systems. The credit includes systems up to 50 MW in capacity, with incentive reductions for large systems within the overall 50-MW capacity limit. This CHP credit is set to expire at the end of 2021 (NCCETC, 2020a).

The second Federal tax incentive is the PTC. The PTC is an inflation-adjusted tax credit for generated electricity from biomass and other renewable energy systems. The PTC for closed-loop and open-loop biomass power generation systems was revived as part of tax legislation at the end of 2019.⁷⁶ The PTC for biomass systems had expired, and it now extends through the end of 2020 (HR 1865, 2019). Qualifying closed-loop biomass systems receive a PTC of \$0.025/kWh of electricity produced for their first 10 years of operation, while qualifying open-loop systems receive \$0.013/kWh, for their first 10 years (IRS, 2020; IRS, 2019, pp. 2–3).⁷⁷

Biomass power generation systems also can receive tax depreciation benefits under the Modified Accelerated Cost Recovery System (NCCETC, 2018). To be eligible for tax credits or accelerated depreciation, the biomass system owner must be a tax-paying entity with sufficient tax liability to absorb the benefits.

USDA Programs

There are also Federal incentives (loan guarantees and grants) specific to rural America that are administered by USDA and that apply to biomass power generation technologies, as well as other renewable generation technologies. Three active incentive programs are summarized below, and other recent programs are described in footnotes.^{78,79}

- Rural Energy for America Program “provides guaranteed loan financing and grant funding to [help] agricultural producers and rural small businesses [adopt] renewable energy systems or make energy efficiency improvements” (USDA, 2020b). Loan guarantees are available for “up to 75 percent of eligible project costs” and grants for “up to 25 percent of eligible project costs,” with a loan maximum of \$25 million and a renewable energy grant maximum of \$500,000 (USDA, 2019d).⁸⁰
- Community Wood Energy and Wood Innovation Program, administered by the U.S. Forest Service, includes the goals of expanding wood energy markets and reducing wildfire risks.⁸¹ Maximum

⁷⁵ The Database of State Incentives for Renewables & Efficiency®, or DSIRE® (www.dsireusa.org), is a website for exploring State-level financial incentives and enabling policies for various biomass feedstock and power generation technologies. The CHP Policies and Incentives Database, or dCHPP (www.epa.gov/chp/dchpp-chp-policies-and-incentives-database), is a similar source for those specifically interested in CHP projects.

⁷⁶ Closed-loop biomass systems are those fueled by “organic material ... planted exclusively to be used at a qualified facility to produce electricity” (AgMRC, p. 2). Open-loop systems can be fueled by a wide range of agricultural and forestry residues and wastes (AgMRC, p. 2).

⁷⁷ Qualifying biomass power generation systems can claim the ITC in lieu of the PTC (IRS, 2019, p. 1).

⁷⁸ The USDA’s High Energy Cost Grants Program is currently closed; however, it was active through 2019. That program provided funding for “renewable energy facilities, including solar, wind, hydropower or biomass technologies used ... on- or off-grid” (USDA, 2020a; USDA, 2019b). The program focused on household and community energy improvements. In 2019, the program provided eight awards to projects in Alaska, totaling about \$13 million (USDA, 2019c).

⁷⁹ The USDA’s Biomass Crop Assistance Program provided funding associated with “growing, maintaining, and harvesting” agricultural or crop residues, woody agriculture residues, and woody forest residues “for energy or biobased products” (USDA, 2016a). It had active funding through fiscal year 2017 (NSAC, 2019).

⁸⁰ Within this program, there is also the opportunity for renewable energy technical assistance and site assessment grants of up to \$100,000 per fiscal year (USDA, 2019e).

⁸¹ For a list of wood energy projects funded by fiscal year, see USDA, 2020c.

individual awards of \$250,000 are available in 2020, with a matching fund requirement, up to an annual total of \$8 million in awards for the Wood Innovations portion of the program (USDA, 2019f, p. 5). In 2019, there were 41 awards in that part of the program (USDA, 2019f, p. 11). There also is a recently re-authorized Community Wood Energy portion of the program, providing matching grants of up to \$1.5 million each to develop, acquire, or upgrade wood energy systems operated by State and local governments, or other groups of energy consumers (USDA, 2019g, pp. 52, 148–149).

- Rural Energy Savings Program offers loans to entities such as utilities, cooperatives, and municipalities that then re-loan the funds to rural households and small businesses to implement cost-effective energy technologies, including on-grid and off-grid renewable energy and energy storage (NARA, 2020).

State Incentive Policies

State incentives can include full or partial exemptions from property and/or sales taxes⁸² for biomass systems, renewable energy certificate (REC) markets, capital cost rebates, discounted loans, and other mechanisms. REC compliance markets are enabled by a Renewable Portfolio Standard (RPS) or a Clean Energy Standard (CES), which are State-level regulatory mandates or goals for a specified portion of the energy sold or generated in a State to come from eligible renewable electricity or clean energy sources such as biomass.^{83,84}

Net metering policies are established at the State or local utility level and define both (1) what size and other characteristics of generation projects interconnected with household or business customer meters are eligible for compensation from the utility for excess production, and (2) what compensation they receive for such excess production.⁸⁵ Forty-one States offer net metering, and additional States have specific utilities that offer net metering or have alternative compensation concepts for generation connected behind the end-use customer's electric utility meter (NREL, 2020). Compensation for excess production can vary from zero to the full retail electricity rate.

Feed-in tariffs are production-based incentives that facilitate the deployment of biomass power generation systems by providing revenue certainty through long-term, price-controlled agreements. An example is the California Bioenergy Market Adjusting Tariff (BioMAT) program, in which small, utility-scale biomass systems (up to 5 MW of capacity, with no more than 3 MW of power delivered to the utility grid at any time) can obtain 10-, 15-, or 20-year contracts to export electricity to California's investor-owned utilities (CPUC, 2020; PG&E, 2020). Qualifying biomass systems using byproducts of sustainable forest management can obtain contracts priced at approximately \$199/MWh (CPUC, 2020).

Three additional State incentive programs specifically for biomass systems are described in *exhibit 3-16*.

⁸² The application of tax exemptions varies. Some States have blanket exemptions for eligible systems, while others have a case-by-case review process or leave all exemption decisions to local taxing jurisdictions. Kansas is an example of a State with a blanket, 10- to 11-year property tax exemption for biomass to energy systems (KSDOC, 2020).

⁸³ RECs are a common mechanism for tracking RPS or CES compliance and "represent the property rights to the environmental, social and other non-power attributes of renewable electricity generation" (EPA, 2020a). RECs function as production-based incentives and also can be purchased for voluntary (non-compliance) purposes. If the owner of a biomass power generation system sells its RECs to improve system economics, only the buyer of the RECs can claim to be buying green power (EPA, 2020a).

⁸⁴ The range of RPS and CES policies in the country is displayed in chapter 5 on wind energy.

⁸⁵ To understand the net metering concept, it can be helpful to visualize an electricity meter spinning backwards when biomass power is being exported to the utility.

EXHIBIT 3-16: Examples of State-Level Biomass Power Generation Financial Incentives

State	Incentive Name	Incentive Description
Georgia	<i>Biomass Sales and Use Tax Exemption</i>	100 percent sales and use tax exemption for biomass materials utilized in the production of energy in the commercial and residential sectors (NCCETC, 2015a).
New Mexico	<i>Biomass Equipment and Materials Compensating Tax Deduction</i>	100 percent of biomass equipment and materials “value may be deducted for the purposes of calculating compensating tax due.” This is equivalent to a sales and use tax exemption (NCCETC, 2016).
South Carolina	<i>Biomass Energy Tax Credit (Corporate)</i>	A credit against the income tax of 25 percent of the purchasing or installation cost of equipment used to create heat, steam, or electricity from biomass resources (NCCETC, 2015b).

Source: NCCETC, 2020b.

Beyond direct financial incentives, there are enabling policies at the State, local government, and utility level that include increasing the ease and speed of permitting, easing the process of complying with zoning and environmental requirements, and facilitating utility interconnection⁸⁶ approvals for biomass systems.

Aggregate Regional Effects

The combined influence of the four drivers discussed previously (feedstock resource, capital and O&M costs, power prices, and incentive policies) is reflected in the net bioenergy power generation map using 2018 data in *exhibit 3-17*.⁸⁷ The States with the highest levels of biomass electricity production are California, Florida, Georgia, and Virginia (EIA, 2020h).

EXHIBIT 3-17: Net Annual Electricity Output From Bioenergy Generation Systems by State (GWh)

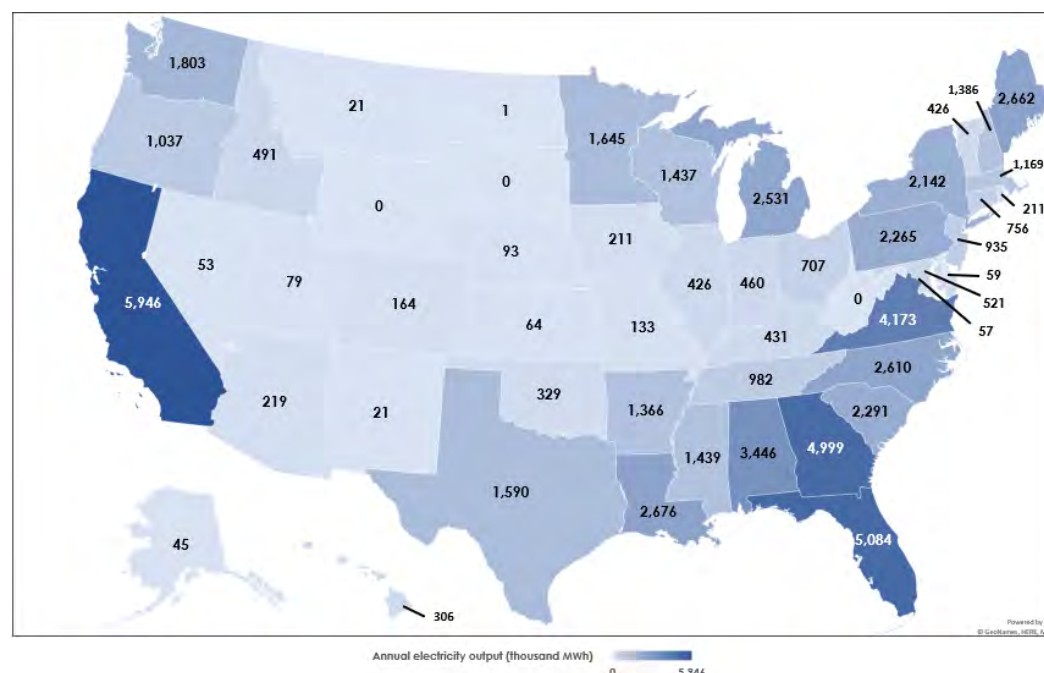

Source: Based on EIA, 2020h (using 2018 data).

⁸⁶ For more information on utility interconnection policies, including State-level distinctions, see IREC, 2019.

⁸⁷ Net generation is the electricity output of a power plant (i.e., “gross generation”) minus electricity consumed on-site for the operation of the power plant by auxiliary equipment (EIA, 2020f). Net generation tends to be only 1 percent to 3 percent less than gross generation for electricity technologies (EIA, 2020g, p. 16).

The top four states in *electricity output* from bioenergy are also the top states in *generating capacity* from bioenergy systems, although in a different order, as displayed in *exhibit 3-18* (DOE, 2020, p. 79). Capacity growth in Virginia has been driven by “a statewide program to convert coal plants to biomass” (EIA, 2016b).

ADOPTION IMPACTS

Six potential environmental and economic impacts associated with farms and forestry operations adopting biomass power generation systems are discussed below.

1. Reduced GHG emissions
2. Potential negative environmental and land use impacts
 3. Improved forest health and wildfire protection
 4. Employment
5. Increased feedstock demand
 6. Energy cost savings and budget certainty for agricultural and forestry businesses

Reduced GHG Emissions

While combusting biomass emits CO₂ into the atmosphere, growing biomass removes it. Combusting biomass for energy then can be viewed as recycling a given quantity of CO₂ emissions to produce a stream of heat and power benefits. In this way, using energy generated from sustainably produced biomass (see below) reduces GHG emissions compared to using energy generated from fossil fuels.⁸⁸

The extent of GHG reductions associated with the adoption of a biomass power generation system depends largely on two factors: (1) location, and (2) the type of feedstock used and its collection and replacement practice sustainability.

Location is important because the energy being replaced by a biomass power generation system is an essential part of the GHG reduction calculation. For example, the GHG reductions from a given biomass system will be lower in an area where grid electricity is largely generated using nuclear, hydropower, wind, or solar technologies than in areas where grid electricity is generated primarily from coal.

The *type and sustainability of the feedstock used* is important because biomass systems, while burning organic material, can be viewed as carbon neutral under some circumstances. The U.S. Environmental Protection Agency (EPA) issued a policy statement in 2018 noting that its “policy in forthcoming regulatory actions will be to treat biogenic CO₂ emissions resulting from the combustion of biomass from managed forests at stationary sources for energy production as carbon neutral” (EPA, 2018a, p. 6). EPA intends to publish a rule in 2020 to classify certain types of forest biomass as carbon neutral, with a rule on the carbon-neutral treatment of agricultural crops to be issued subsequently (Biomass Magazine, 2020; OMB, 2020).⁸⁹

EXHIBIT 3-18: States With the Highest Bioenergy Power Generation Capacity

Rank	State	Bioenergy Power Generation Capacity (MW)
1	Florida	1,416
2	California	1,394
3	Virginia	1,018
4	Georgia	1,007
5	Maine	769
6	Alabama	666
7	North Carolina	633
8	Michigan	616
9	Pennsylvania	601
10	New York	586
TOTAL (10 States)		8,706

Source: DOE, 2020, p. 79.

⁸⁸ Gasification systems are generally lower emitting than combustion systems, with lower emissions of nitrogen oxides, CO, and particulates (NREL, 2009, p. 9).

⁸⁹ Alternative approaches to carbon accounting for biomass systems are followed in certain States and are frequently debated in the scientific community (California Air Resources Board, 2019).

To illustrate the GHG impacts of location and feedstock, GHG calculations for a representative, new 10-MW biomass-fueled power generation system in three States are displayed in *exhibit 3-19*.^{90,91} The emission reductions differ because the carbon intensity of grid electricity in these States differs. In Kentucky, a relatively high share of grid electricity is generated using coal. As a result, the emission reductions from a biomass system are much higher than in the other two States. The opposite is true in Washington State, where the majority of grid electricity is generated by zero-emissions hydropower systems. GHG impacts are displayed if the project is considered carbon neutral by virtue of its feedstock and other attributes, and if it is not deemed to be carbon neutral.⁹² GHG reductions are displayed in metric tons of CO₂ equivalent (CO₂e)⁹³ removed from the electric grid and two alternative GHG reduction metrics.

EXHIBIT 3-19: Estimated Annual GHG Reductions and Equivalencies From a 10-MW Biomass Power Generation System in Selected States

State	Project Considered To Be Carbon Neutral?	Annual GHG Emission Reductions (metric tons of CO ₂ e)	Equivalent Reduction in Number of Passenger Vehicles	Equivalent Reduction in Number of Homes Using Energy
Kentucky	Yes	60,179	13,001	6,944
Florida	Yes	31,069	6,712	3,585
Washington	Yes	6,555	1,416	756
Kentucky	No	34,097	7,366	3,935
Florida	No	4,987	1,077	575
Washington	No	-19,527	-4,219	-2,253

Sources: EPA, 2020b; EPA, 2020c; USAID, 2019; Lazard, 2017.

For biomass power generation systems of different sizes, GHG reductions would be proportionately smaller or larger, depending on system capacity and the capacity factor.

Potential Negative Environmental and Land Use Impacts

While biomass power generation systems reduce GHG emissions in many cases, that is not always the outcome. If the biomass feedstock is not sustainably harvested in a manner considered carbon-neutral, then a biomass power generation system can increase GHG emissions, as occurs in the Washington State example in *exhibit 3-19*. The combustion of organic material in these systems also creates non-

⁹⁰ The GHG emission reduction calculations underlying this exhibit for a carbon-neutral biomass system are as follows: 10-MW biomass power generation system capacity x assumed 82.5 percent capacity factor x 8,760 hours in a non-leap year = 72,270 MWh of electricity output from the biomass system in a year. The biomass capacity factor assumption is the midpoint value between 85 percent and 80 percent (Lazard, 2017, p. 19). State-level emissions factors of CO₂ equivalent (CO₂e) from EPA (EPA, 2020b, p. 4) are converted from pounds/MWh to metric tons/MWh at a ratio of 2,204.623 pounds/metric ton to yield emissions factors of 0.8327, 0.4299, and 0.0907 metric tons of CO₂e/MWh for Kentucky, Florida, and Washington State, respectively. These State-level emissions factors are then multiplied by the annual electricity output of 72,270 MWh to obtain the emission reduction from a 10-MW biomass system considered to be carbon neutral (with no GHG emissions) in each State.

⁹¹ EPA's Greenhouse Gas Equivalencies Calculator (EPA, 2020c) was used to convert annual GHG reductions from the biomass system into equivalent GHG savings from removing passenger cars from the road for a year and removing homes' energy use for a year.

⁹² For the 10-MW biomass system if it is not considered to be carbon neutral, the emissions factor for "other primary solid biomass" of 100,249 grams of CO₂e per gigajoule (GJ) was used (USAID, 2019, p. 206). That data point was converted to metric tons of CO₂e/MWh as follows: divide 100,249 grams by 453.592 to obtain pounds and divide by another 2,204.623 to convert pounds to metric tons, and then multiply by 3.6 to convert metric tons/GJ to metric tons/MWh. The resulting biomass system emissions factor is 0.3609 metric tons of CO₂e/MWh. That factor is subtracted from the default generation mix emissions factor in each State and multiplied by the new biomass system's annual output of 72,270 MWh to calculate the annual GHG emission reduction or increase from introducing the biomass system. In Washington State, the non-carbon-neutral biomass system would increase GHG emissions due to the dominance of hydropower and, to a lesser extent, other renewable sources and nuclear power in that State's generation mix.

⁹³ In EPA's eGRID database, CO₂e is a summary measure that expresses the combined impact of three greenhouse gases (carbon dioxide, methane, and nitrous oxide) as an equivalent CO₂ impact. For more information on CO₂e calculations, see EPA, 2012b.

CO₂ air emissions and causes nitrogen deposition that can acidify soils and waters and, thereby, affect species composition.

Beyond air emissions, there are other potentially negative environmental impacts of these systems. Biomass power generation systems, apart from those with dry cooling technologies, tend to use large amounts of water as they operate. For example, a steam combustion system uses about 550 gallons of water per MWh of electricity produced (NREL, 2011, p. 12). That is less water use than natural gas steam combustion systems but more than natural gas combined cycle systems (NREL, 2011, p. 13).⁹⁴

Though not currently a significant biomass feedstock source, if purpose-grown agriculture crops like Miscanthus and switchgrass are scaled up, changes in land use and crop production patterns could result. Increasing the quantity of land in energy crop production could result in reductions of land now in grasses, forests, habitat, recreation, and other uses (see also EIA, 2019b). Depending on local and regional circumstances, these changes may not be considered desirable by many.

For woody biomass sources, over-aggressive collection practices can lead to forest overthinning: “treatments that substantially reduce canopy cover can exacerbate fire danger through their effect on the understory microclimate and vegetation” (CEC, 2011, p. 115).

Improved Forest Health and Wildfire Protection

Managed properly, increased biomass energy production can promote forest health and decrease wildfire danger in many areas of the country (DOE, 2016b, p. 12). For example, in many Western States,

Honey Lake Power Facility, California

Honey Lake Power is a 30-MW biomass power generation system in Lassen County, CA. The plant burns 150,000 to 200,000 tons of woody biomass from forest-derived fuels, urban wood waste, and sawmill byproducts each year (Greenleaf Power, 2020). Of that annual **feedstock supply**, “about 140,000 bone dry tons are acquired from forest thinning and fuels reduction” (USDA, 2019h). In 2014, the facility was one of 36 facilities selected by USDA to accept biomass deliveries supported by the Biomass Crop Assistance Program (BCAP) (USDA, 2014b). Some BCAP payments “**target** the removal of dead or diseased trees from National Forests and U.S. Bureau of Land Management public lands for renewable energy, which reduces the risk of forest fire” (USDA, 2014b).

large areas of forest have become overcrowded with small-diameter younger trees, large numbers of dead and dying trees, and dangerous quantities of organic debris on the forest floor. As a result, forests have become more susceptible to drought, beetle-kill infestation, and extreme wildfires (Los Angeles Times, 2017). Actively thinning these forests and using the woody biomass for energy generation can reduce fire risks and improve the health of existing trees by giving them better access to water and nutrients (Stephens, et al., 2018, p. 85). The Honey Lake Power facility (see the box on this page) is an example of a system that has produced these benefits.

⁹⁴ In comparison, wind power systems use almost no water, and utility-scale PV systems average 26 gallons per MWh (NREL, 2011, p. 12).

Employment

There were approximately 13,000 jobs in 2019 involved with bioenergy power generation, as shown in *exhibit 3-20*.^{95,96} Construction and professional and business services are the largest job sectors, accounting for more than two-thirds of all jobs.

Increased Feedstock Demand

The deployment of biomass energy systems can increase demand for, and the prices of, biomass feedstocks and related commercial activities. For example, a 3-MW (or 3,000-kW) biomass combustion system would consume about 14,000 dry U.S. tons of biomass per year,⁹⁷ potentially generating an expanded market for nearby feedstocks, which, in turn, can expand local transportation and coproduct industries (DOE, 2016b, p. 19). For more information on several biomass feedstock markets, see chapters 8 and 9.

Energy Cost Savings and Budget Certainty

Agricultural and forestry businesses utilizing energy from biomass can obtain savings on their overall operating expenses. This is particularly important when energy represents a large share of total costs. As shown in *exhibit 3-21*, producers of several agricultural commodities typically spend more than 3 percent of their overall budgets on electricity. Agricultural firms can spend several percent more of their annual costs on non-electricity fuels (USDA, 2016b, p. 7).⁹⁸

EXHIBIT 3-20: Bioenergy Power Generation Employment by Sector in the United States

Sector Within Bioenergy Generation	2019 Employment	Sector Share of Employment
Construction	5,809	44.1%
Professional and Business Services	3,317	25.1%
Utilities	1,897	14.4%
Manufacturing	1,133	8.6%
Wholesale Trade	576	4.4%
Other	446	3.4%
TOTAL	13,178	100%

Source: NASEO, 2020, p. 81.

⁹⁵ The 2020 U.S. Energy and Employment Report relies on employment data from the BLS Quarterly Census of Employment and Wages (QCEW) and supplemental surveys (NASEO, 2020, p. 201).

⁹⁶ Additional employees associated with bioenergy power projects may be included in the CHP category of this report (NASEO, 2020, p. 63).

⁹⁷ This calculation assumes a capacity factor of 82.5 percent for the system, a heat rate of 10,500 Btu/kWh, and energy content of 8,000 Btu per dry pound of biomass, and is 3,000-kW generation capacity x 82.5 percent capacity factor x 8,760 hours per year x 10,500 Btu/kWh heat rate ÷ 8,000 Btu/pound energy content ÷ 2,000 pounds per ton.

⁹⁸ Livestock businesses tend to have a high percentage of energy-based expenses. These business types can be readily paired with anaerobic digestion technologies that utilize byproducts such as animal manure.

EXHIBIT 3-21: Farm Business Electricity Expenses as a Percentage of Total Cash Expenses

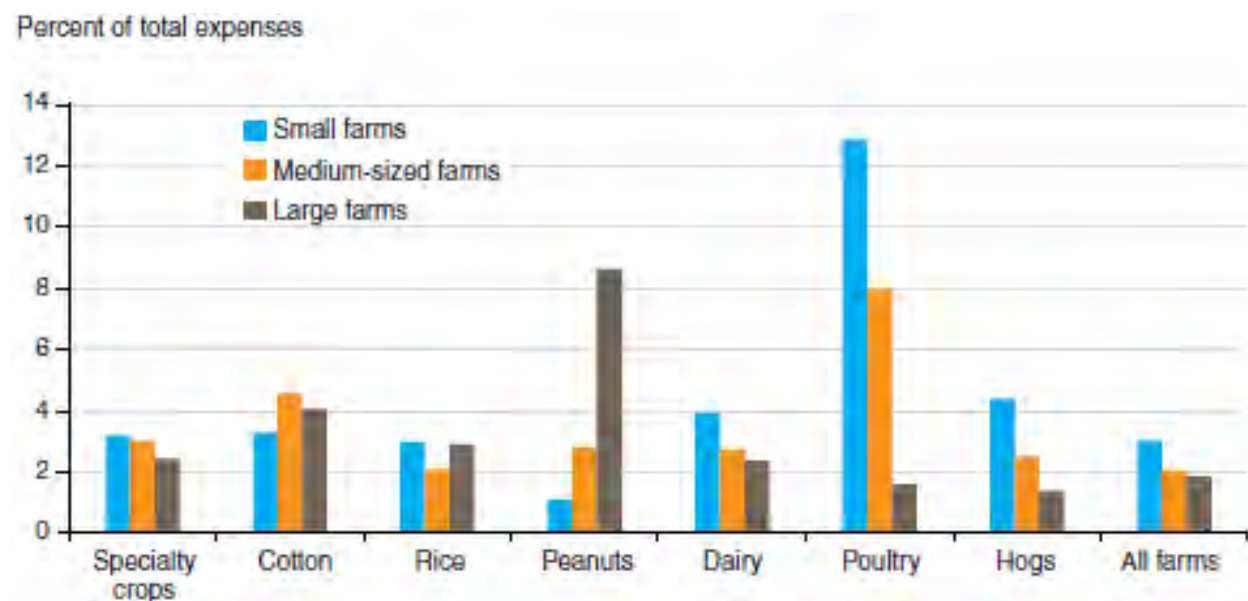

Source: USDA, 2016b, p. 10.⁹⁹

To the extent that electricity and fuel costs are higher shares of overall budgets in a sector or region, businesses have more reason to investigate self-generation options. This can especially be the case for biomass CHP projects that produce two forms of energy—electricity and thermal energy such as hot water, steam, hot air, or chilled water (by running waste heat through an absorption chiller).

In addition to the cost savings benefit, biomass systems can provide electricity and heat budget certainty to the consumers of their energy. Electricity and fuel prices fluctuate year to year, and they are affected by general price inflation and other factors. For entity-scale applications, a biomass system may utilize a reliable source of feedstock on-site or secure a long-term feedstock supply contract from farm businesses or forested lands nearby. In such cases, the biomass system host can substitute a known, long-term cost of producing or buying electricity and/or heat for the fluctuating and unpredictable cost of purchasing electricity, natural gas, propane, or other fuels from the utility or other external suppliers.

⁹⁹ On this chart, “small, medium, and large farms are categorized as [those with] gross [annual] cash farm income under \$350,000, between \$350,000 and \$999,999, and \$1 million and over, respectively” (USDA, 2016b, p. 10).

An example of a farm-level biomass energy system that produces heat, but not electricity, is described in the box below.

Biomass Direct Heat Example: Outdoor Wood Boiler

Blais Farm grows vegetables, strawberries, flowers, and herbs on 38 acres of farmland in Springfield, VT. The farm uses hot water from an outdoor biomass (wood) boiler with a capacity of 764 gallons to heat four greenhouses used for bedding plant and tomato production, as well as a barn and the farmer's home. Prior to installation of the biomass boiler, the farm used about 2,500 gallons of #2 fuel oil to heat these structures annually. Insulated underground pipes now carry hot water from the biomass boiler to the various structures and heat exchangers that release the heat. The entire system cost \$25,000. Blais Farm has access to low-cost wood scraps as feedstock, which means that the annual fuel savings were approximately \$3,000 when the system was first installed (UVM, 2008).



Image Source: UVM, 2008.

DOMINANT OWNERSHIP/FINANCING MODEL

There are basically two ownership models used for biomass power generation systems.

1. Self-Ownership involves the farm or forestry business owning the equity in the biomass system, with or without outside loans. This model is particularly common for entity-scale systems, such as those at pulp and paper producers, lumber and plywood mills, and sugar refineries that use both heat and power from biomass combustion.
2. Third-Party Ownership includes situations where the farm or forestry operation does not own the biomass power generation system. These systems may be located on the operation or off-site. Either way, the system is typically owned by an independent power producer and is designed for wholesale power sales.

For on-site systems, various business structures may be employed. These include simple leasing of the equipment that is then operated by and for the benefit of the farm or forestry operation, or full third-party ownership. In the latter case, the farm or forestry operation would typically purchase electricity and thermal energy produced from the biomass system via contract at a known price. Third-party ownership structures place capital investment requirements and operational risk on the third party rather than the farm or forestry business host.

The choice of ownership structure depends on such factors as the availability of investment capital, the technical and operational sophistication of the agricultural or forestry sector host, the risk tolerance of the host, and the ability of the host or third-party owner to utilize tax credits.

ANAEROBIC DIGESTERS

Introduction

Thus far, this chapter has focused on the conversion of cellulosic agricultural and forestry biomass into electricity and heat, primarily through combustion, but also through gasification. Anaerobic digestion (AD) is another process that can convert organic wastes into energy. In the AD process, organic matter in the waste stream is first converted to volatile fatty acids by acidogenic bacteria, which are then

converted to a biogas by methanogenic bacteria. The biogas is primarily methane (55–70 percent) and CO₂ (30–45 percent) with trace amounts of hydrogen sulfide, ammonia, and nitrous oxide (ICF, 2013, p. 3.4).

AD is a particularly relevant energy option in confined livestock operations (particularly for dairy and swine) and urban settings because AD systems can extract biogas from animal manure, crop residues, food waste, sewage effluent, and other organic waste streams. The methane in the biogas can be purified and then combusted on-site at the farm in a combustion turbine generator or reciprocating engine generator to produce electricity and/or heat.

AD is an effective option for reducing the GHG emissions associated with confined dairy and swine operations. If the waste from these operations is treated and stored in open anaerobic systems (e.g., in a pit, pond, or lagoon), the methane produced during solids decomposition will escape directly to the atmosphere. In contrast, if the waste is in an AD system, the biogas is captured. It can then be combusted to produce electricity and/or heat, or can simply be flared if the system does not have energy production technologies. In either case, the AD process results in the conversion of the methane in the biogas to CO₂ gas, which is a less potent GHG than methane.¹⁰⁰

There is a significant amount of literature¹⁰¹ that discusses AD applications in the agricultural sector in detail. Hence, this section contains only a brief summary of AD, and is divided into four sub-sections:

- Technology characterization
- Current state of adoption and regional distinctions
- Other benefits of AD systems
- Adoption costs

Technology Characterization

Four technology designs for AD systems that are used to manage manure streams on confined livestock operations are profiled in this section. These designs cumulatively account for 95 percent of operating AD systems on U.S. livestock farms (EPA, 2020f).

Covered Lagoon Digester: These systems utilize liquid manure with less than 5 percent solids. Large lagoon volumes are typically required, with depths greater than 12 feet. Covered lagoons for energy recovery, like those shown in *exhibit 3-22*, are compatible with flush manure systems in temperate or warm climates.

EXHIBIT 3-22: Covered Lagoon Anaerobic Digester System Diagram

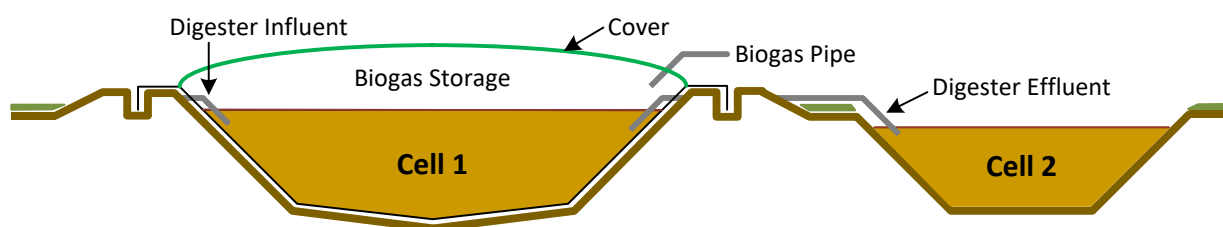

Source: EPA, 2020g.¹⁰²

¹⁰⁰ Methane has a global warming potential 28 to 36 times that of CO₂ over 100 years (EPA, 2020d).

¹⁰¹ See, for example, EPA, 2020e, NYSERDA, 2014, and ICF, 2013.

¹⁰² Cell 1 in the diagram denotes raw manure and liquid waste, and Cell 2 is the effluent "digestate" after digestion.

Plug Flow Digester: Heated, rectangular tank systems, like those shown in *exhibit 3-23*, utilize scraped dairy manure with a range of 12 percent to 15 percent solids. Swine manure cannot be readily treated with a plug flow digester due to its lack of fiber.

EXHIBIT 3-23: Plug Flow Anaerobic Digester System Diagram

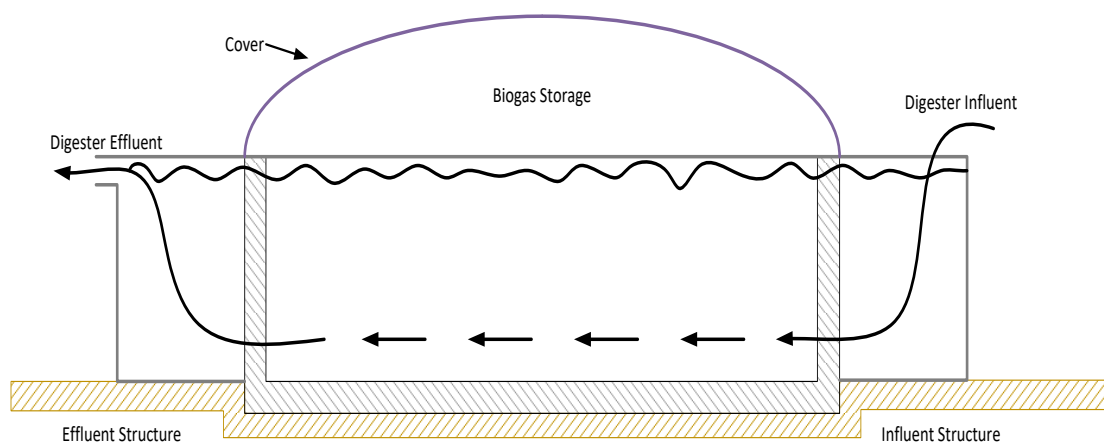

Source: Adapted from EPA, 2020g.¹⁰³

Complete Mix Digester: Tank systems, above or below the ground, utilize slurry manure with solids in the range of 3 percent to 10 percent. These structures require less land than lagoons, and are heated, as shown in *exhibit 3-24*. Complete mix digesters are most compatible with combinations of scraped and flushed manure, as well as other wastes from meat processing, other food sources, and crop residues.

EXHIBIT 3-24: Complete Mix Anaerobic Digester System Diagram

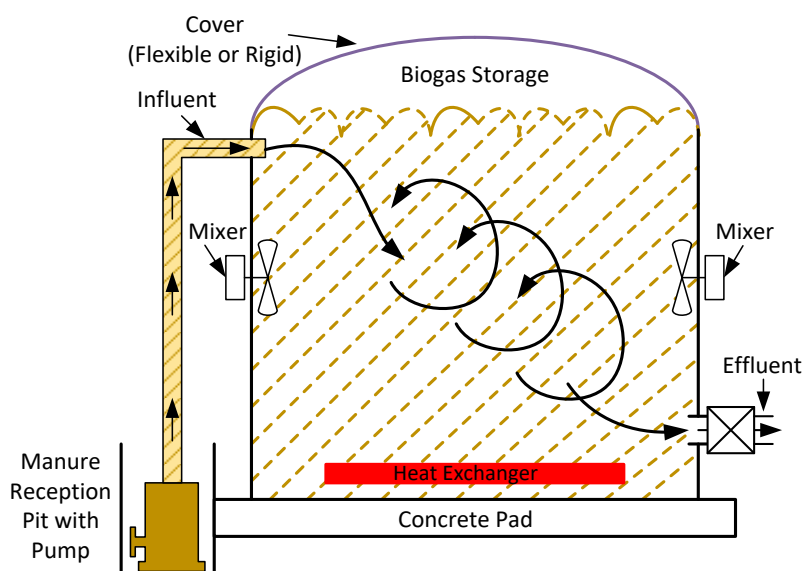

Source: Adapted from EPA, 2020g.

¹⁰³ "Influent Structure" and "Effluent Structure" refer to areas in the AD system where raw manure and liquid waste enter the digester and the digester effluent ("digestate") exit the digester, respectively.

Dry or Fixed-Film Digester: Tank systems are filled with plastic media that support a thin layer of anaerobic bacteria called “biofilm” (hence the term “fixed-film”). As the waste manure passes through the media, biogas is produced. Like covered lagoon digesters, fixed-film digesters are best suited for the dilute waste streams (with approximately 3 percent solids on average) typically associated with flush manure handling or pit recharge manure collection. Fixed-film digesters can be used for dairy and swine wastes. However, separation of dairy manure is required to remove slowly degradable solids, as shown in *exhibit 3-25*.

Exhibit 3-26 summarizes the characteristics of these four types of AD systems.

EXHIBIT 3-25: Fixed-Film Anaerobic Digester System Diagram

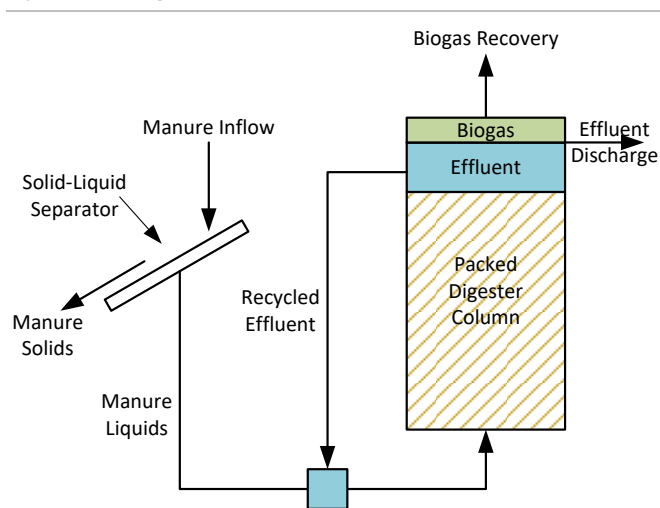

Source: Adapted from USDA, 2019i.

EXHIBIT 3-26: Characteristics of Common Anaerobic Digester System Types

Characteristic	Covered Lagoon Digester	Complete Mix Digester	Plug Flow Digester	Dry or Fixed-Film Digester
Digestion Vessel	Deep Lagoon	Round or Square, In- or Above-Ground Tank	Rectangular In-Ground Tank	Above-Ground Tank
Total Solids	0.5% – 5%	3% – 10%	12% – 15%	1% – 5%
Hydraulic Retention Time (average days that manure remains in the digester)	30–60+	15+	20+	5 or less
Optimum Geography	Temperate and Warm Climates	All Climates	All Climates	All Climates, if heated

Source: EPA, 2020e, pp. 3-9, 3-11, 3-12, 3-16.

Current Level of Adoption and Regional Distinctions

As of March 2020, there were 255 operational AD systems on U.S. livestock farms, including 205 on dairy farms, 44 on hog farms, 8 on beef farms, and 7 on poultry farms (EPA, 2020h).^{104,105,106} As shown in *exhibit 3-27*, the number of AD systems on livestock farms has remained nearly constant for the past 8 years after experiencing tenfold growth between 2000 and 2012. A main reason for the lack of growth is the decline in market prices for natural gas—the product for which AD-produced biogas substitutes (EPA, 2017b, p. 11).¹⁰⁷

¹⁰⁴ AD systems on poultry farms are rare because manure from poultry facilities, in contrast to manure from dairy and swine operations, has a relatively low moisture content, which inhibits the efficient degradation of organic material in AD systems.

¹⁰⁵ The total exceeds 255 as some projects accept manure from more than one livestock type (EPA, 2020h).

¹⁰⁶ Beyond farm applications, AD is a relatively common process for sewage solids stabilization at municipal and industrial water resource recovery plants (WEF, 2017). There are more than 1,200 AD systems at such plants, with more than one-half of those systems producing electricity or usable heat (EPA, 2020i).

¹⁰⁷ Low milk prices, interconnection issues, and market and policy uncertainties are identified as other barriers to AD system growth (EPA, 2017b, p. 12).

EXHIBIT 3-27: Historical U.S. Market Size for Anaerobic Digesters on Livestock Farms



Source: EPA, 2020f.

Of the AD systems currently in place on U.S. livestock farms, 38 percent are plug flow systems, 34 percent are complete mix systems, 22 percent are covered lagoon systems, 1 percent are fixed-film systems, and 5 percent are other or unknown types of AD systems (EPA, 2020f). The States with the most AD systems on livestock farms are, in descending order, Wisconsin, Pennsylvania, New York, and California (EPA, 2020h). That order closely matches the States with the most total milk production.¹⁰⁸

The potential for profitable AD systems in the dairy and swine livestock sectors is more than 30 times higher than current deployment levels. Those livestock farms considered to have the best economic potential for AD “are large operations (500 or more head of cow or 2,000 or more head of swine) that use liquid or slurry manure handling systems and collect manure often from animal confinement areas” (EPA, 2018b, p. 7). An estimated 8,113 swine and dairy farms in the United States have such potential (EPA, 2018b, p. 4).¹⁰⁹ Exhibit 3-28 and exhibit 3-29 display the regional distribution of these swine and dairy farms that are considered candidates for future AD systems.

EXHIBIT 3-28: Number of Swine Farms With Potential for Anaerobic Digester Systems

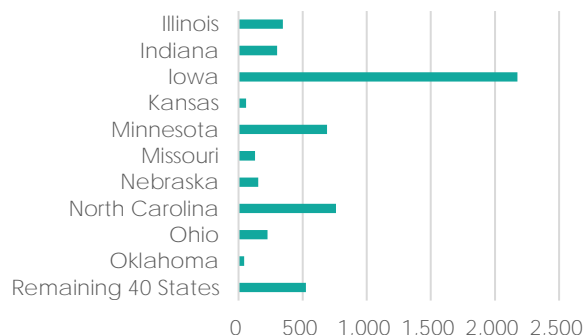

Source: Based on EPA, 2018b, p. 10.

EXHIBIT 3-29: Number of Dairy Farms With Potential for Anaerobic Digester Systems

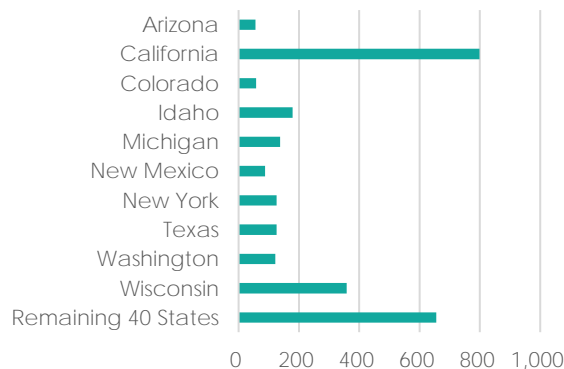

Source: Based on EPA, 2018b, p. 10.

¹⁰⁸ The seven States with the highest milk production in 2019 were California, Wisconsin, Idaho, New York, Texas, Michigan, and Pennsylvania (Farm Bureau, 2020).

¹⁰⁹ For an additional review of the deployment potential for various AD system types, see ICF, 2013, p. 3.10, 3.23–3.24, and 3.36.

Other Benefits of AD Systems

In addition to generating energy and GHG emission reductions, AD systems have several other potential economic and environmental benefits.

The non-gaseous material remaining after the AD process is a wet mixture called digestate, which is typically separated into a solid and a liquid (EPA, 2020g). Both the solids and liquids are rich in nitrogen and other nutrients and are often applied to cropland as a fertilizer. The liquid portion also can be used for irrigation, while the solid portion is often used for animal bedding, as a soil enhancement, or sold as compost (EPA, 2020g).¹¹⁰

With respect to environmental benefits, manure treated with AD has much less odor when applied to agricultural fields than manure treated without AD (EPA, 2018b, p. 5). AD processes also are effective at reducing levels of bacteria and other pathogens from manure that may enter soils or surface waters and pose risks to human or animal health (EPA, 2018b, p. 5). The degree of reduction is largely determined by the temperature inside the digester and the time the manure is retained in the digester. Pathogen levels in manure can be reduced 95 percent using a 20-day retention time and an internal mesophilic digester temperature of 95 degrees Fahrenheit (°F) to 105°F, with higher pathogen elimination with thermophilic digestion at 122°F to 140°F (Penn State, 2012).

Adoption Costs

Costs for AD systems can vary widely due to factors such as the following:

- Design type (e.g., covered lagoon, plug flow, complete mix, fixed-film)
- Capacity
- Feedstock types (e.g., animal manure, agricultural residues, food waste) and collection practices
- Feedstock solids percentage
- Biogas and recovered products
- Ability of existing farm infrastructure to consume the energy produced

Positive financial returns are most likely at dairy operations with milking herds of at least 500 cows or at swine operations with at least 2,000 total head of confinement capacity (EPA, 2018b, p. 7). Capital, O&M, and total energy production costs for AD systems in the United States are summarized below.

Because there is little publicly available data on AD system costs and because costs vary substantially between systems, the data should be viewed as indicative.

¹¹⁰ The economic value of digestates ranges from near zero to levels in excess of the value of electricity produced from anaerobic digester biogas. See, for example, CEO, 2014, p. 22, and NREL, 2013, p. 33. In some cases, carbon offsets from AD systems may be sold for additional economic value, although doing so affects the environmental claims that the system owner can make about the AD system, because it has separated the environmental value from the AD system and transferred it to the carbon offset buyer.

Capital Costs

Capital costs reflect the all-in costs of installing a new AD system. *Exhibit 3-30* and *exhibit 3-31* show these costs for swine and dairy farms, respectively. The economies of scale are substantial; for example, unit (per animal) capital costs decline by more than one-half as the number of swine producing waste for the AD system rises from 150 to 500 (see *exhibit 3-30*). For both types of livestock farms and for all system sizes except the largest dairy farms, complete mix digesters are the least costly type.

Operations & Maintenance Costs

O&M costs also depend on AD design, capacity, and feedstock. Annual O&M costs average approximately 4 percent of the capital cost (ICF, 2013, pp. 3-13, 3-27, and 3-39). Depending on AD system specifics, annual O&M costs may be 2.3 percent to 7.0 percent of capital cost (USDA, 2007, p. 4).

Energy Production Costs

Typical energy production costs for a large (5,000-cow unit) AD system are approximately \$6 to \$7/MMBtu (Zullo, 2016, p. 13). In addition to the factors causing variation in capital and O&M costs, location can be an important factor in the overall output cost of producing biogas.¹¹²

EXHIBIT 3-30: Estimated Capital Cost per Swine for Anaerobic Digester Systems on Swine Farms

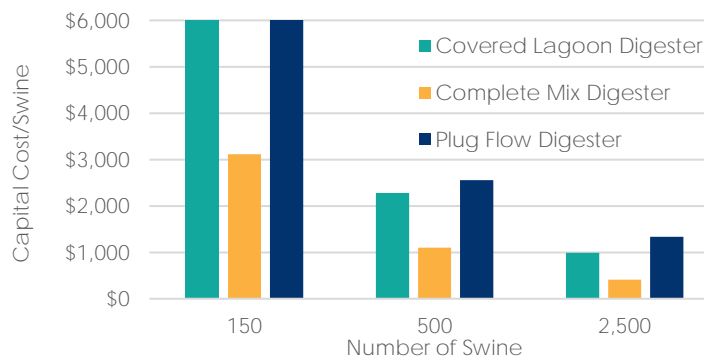

Source: ICF, 2013, pp. 3.14, 3.28, and 3.40.¹¹¹

EXHIBIT 3-31: Estimated Capital Cost per Dairy Cow for Anaerobic Digester Systems on Dairy Farms

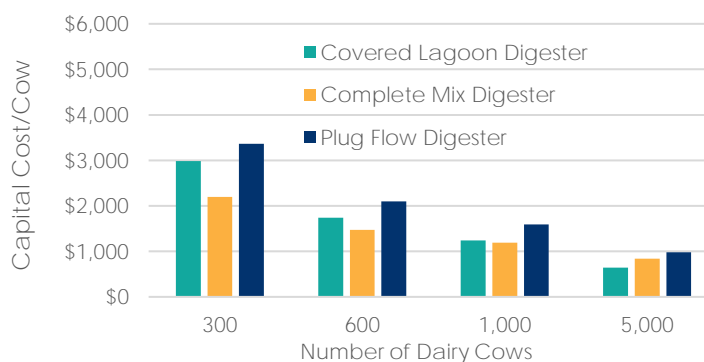

Source: ICF, 2013, pp. 3.12, 3.26, and 3.38.

CHALLENGES TO EXTENDING ADOPTION

In contrast to wind energy and PV technologies, biomass power generation technologies, including anaerobic digestion, have not grown significantly in recent years in the United States. There are four key reasons why, all of which pose challenges to increasing adoption of biomass systems:

No significant improvements in system economics. The dominant energy generating technology (combustion) used to convert biomass to electricity has not seen significant improvements in cost or performance in recent years. In contrast, wind and solar technologies have seen both due to realizing economies of scale and from technical innovation. Alternative biomass generation technologies such as gasification are not yet commercially viable without significant subsidies, although they tend to be more efficient than traditional combustion (boiler with steam turbine) systems.

¹¹¹ Capital cost data are in 2010 dollars in the 2013 report. For *exhibit 3-30* and *exhibit 3-31*, data were converted to 2020 dollars using the BLS Consumer Price Index Inflation Calculator (<https://data.bls.gov/cgi-bin/cpicalc.pl>), which increased prices by an aggregate 18 percent between December 2010 and January 2020.

¹¹² Systems in northern climates may require additional heating for the microorganisms in the digester to work properly. Locations in southern climates may require some level of cooling so the microorganisms do not overheat.

Comparatively low costs of conventional electricity. Another challenge is the low cost of conventional electricity in many regions of the United States, due in large part to historically low natural gas prices. For example, between mid-2014 and mid-2018, wholesale electricity prices declined or remained flat in several market areas (EIA, 2020i). Retail electricity prices for industrial customers such as agricultural and forestry businesses have been almost entirely flat, increasing less than 1.5 percent in aggregate between 2009 and 2018 (EIA, 2020a, table 5.3). At the same time, biomass feedstock costs have not substantially declined, making it more difficult for electricity generated by biomass-fueled systems to compete with grid-supplied electricity.

Expiring Federal tax incentives. The expiration of the Federal PTC for biomass power generation systems in December 2017 significantly decreased expected returns on investments in biomass systems. The reinstatement of the PTC at the end of 2019 for biomass systems that commence construction by the end of 2020 should provide a short-term boost to the industry. However, most PTC-eligible systems should become operational by 2023, after which expected returns from these systems are likely to decline.

Lack of State-level financial incentives. Finally, State subsidies specifically for biomass technologies beyond those for other renewable technologies are not as common as they are for solar technologies. For example, in New Jersey, Maryland, and the District of Columbia, there are specific sub-requirements in the State RPS for solar deployment, which raise the prices for solar RECs well above those for RECs from biomass and other eligible renewable generation technologies. In addition, in some States, the eligibility of biomass for REC payments is limited in relation to solar and wind technologies.

REFERENCES

- AgMRC. *The Law of Biomass—Tax Issues*. Steel Rives LLP for Agricultural Marketing Resource Center. https://www.agmrc.org/media/cms/Tax_Issues_6D6DB342E7419.pdf [accessed February 2020].
- All Power Labs. 2020a. Biodico, Redrock Ranch, Five Points, Fresno County, California. <http://www.allpowerlabs.com/people/gek-users/industry-forestry-ranching-and-farming/biodico> [accessed February 2020].
- All Power Labs. 2020b. PP20 – Discontinued. <http://www.allpowerlabs.com/products/pp20-discontinued> [accessed February 2020].
- Biomass Magazine. 2019. U.S. Biomass Power Plants. <http://biomassmagazine.com/plants/listplants/biomass/US/> [accessed February 2020].
- Biomass Magazine. 2020. Senate Hearing Addresses Wood Stoves, RFS and Biomass Neutrality. <http://biomassmagazine.com/articles/17079/senate-hearing-addresses-wood-stoves-rfs-and-biomass-neutrality> [accessed May 2020].
- Biomass Power Association. 2020. Wadham Energy Limited Partnership. <https://www.usabiomass.org/pnw-members/wadham-energy-limited-partnership/> [accessed February 2020].
- Black & Veatch. 2013. *Small-Scale Bioenergy: Resource Potential, Costs, and Feed-in Tariff Implementation Assessment*. ftp://ftp2.cpuc.ca.gov/PG&E20150130ResponseToA1312012Ruling/2013/04/SB_GT&S_0874313.pdf [accessed February 2020].
- California Air Resources Board. 2019. *Biomass-Derived Fuels Guidance for California's Mandatory GHG Reporting Program*. <https://ww3.arb.ca.gov/cc/reporting/ghg-rep/guidance/biomass.pdf> [accessed February 2020].
- CEC. 2011. *Potential Positive and Negative Environmental Impacts of Increased Woody Biomass Use for California*. California Energy Commission. <https://ucanr.edu/sites/forestry/files/161616.pdf> [accessed August 2020].
- CEO. 2014. *Colorado Market Assessment of Agricultural Anaerobic Digesters*. Colorado Energy Office. <https://www.colorado.gov/pacific/sites/default/files/atoms/files/Market%20Assessment%20of%20Colorado%20Agricultural%20Anaerobic%20Digesters.pdf> [accessed February 2020].
- Copenhagen Post. 2014. DONG Closes Down High-Profile Gasification Plant. <http://cphpost.dk/?p=3416> [accessed May 2020].
- CPC. 2019. Telephone Conversation between Community Power Corporation and ICF. June 25, 2019.
- CPUC. 2020. Bioenergy Feed-in Tariff Program (SB 1122). California Public Utilities Commission. http://www.cpuc.ca.gov/sb_1122/ [accessed February 2020].
- DOE. 2012. U.S. Department of Energy Flickr. U.S. Department of Energy. <https://www.flickr.com/photos/departmentofenergy/9443064499/in/photolist-o3tKb2-nKZjF7-nL1ciB-fosb5T-cAsGRd-cA1cf5-nPUSCT-nL5K27-nvDjVX-nL5NHq-nPUVaB-nPUT7Z-nvDiKv-nvCRn3-nN5psd-nvCAZp-nN8sac-nvCL6E-nPUTSg/> [accessed February 2021].
- DOE. 2015. *Quadrennial Technology Review, Chapter 4: Advancing Clean Electric Power Technologies, Biopower*. U.S. Department of Energy. <https://www.energy.gov/sites/prod/files/2015/12/f27/QTR2015-4B-Biopower.pdf> [accessed February 2020].
- DOE. 2016a. *2016 Billion-Ton Report: Advancing Domestic Resources for a Thriving Bioeconomy, Volume 1: Economic Availability of Feedstocks*. U.S. Department of Energy. https://www.energy.gov/sites/prod/files/2016/12/f34/2016_billion_ton_report_12.2.16.pdf [accessed February 2020].
- DOE. 2016b. *Strategic Plan for a Thriving and Sustainable Bioeconomy*. U.S. Department of Energy. https://www.energy.gov/sites/prod/files/2017/09/f36/beto_strategic_plan_december_2016.pdf [accessed February 2020].
- DOE. 2020. *2018 Renewable Energy Data Book*. U.S. Department of Energy. <https://www.nrel.gov/docs/fy20osti/75284.pdf> [accessed March 2020].
- EIA. 2016a. *Capital Cost Estimates for Utility Scale Electricity Generating Plants*. U.S. Energy Information Administration, DOE. https://www.eia.gov/analysis/studies/powerplants/capitalcost/pdf/capcost_assumption.pdf [accessed February 2020].
- EIA. 2016b. Southern States Lead Growth in Biomass Electricity Generation. U.S. Energy Information Administration, DOE. <https://www.eia.gov/todayinenergy/detail.php?id=26392> [accessed February 2020].
- EIA. 2017. Biomass and Waste Fuels Made Up 2% of Total U.S. Electricity Generation in 2016. U.S. Energy Information Administration, DOE. <https://www.eia.gov/todayinenergy/detail.php?id=33872> [accessed February 2020].

- EIA. 2019a. State Electricity Profiles (Release Date: December 31, 2019). U.S. Energy Information Administration, DOE. <https://www.eia.gov/electricity/state/> [accessed February 2020].
- EIA. 2019b. Biomass Explained: Biomass and the Environment. U.S. Energy Information Administration, DOE. <https://www.eia.gov/energyexplained/biomass/biomass-and-the-environment.php#:~:text=Energy%20Information%20Administration%20-%20EIA%20-%20Official%20Energy,impacts%20of%20producing%20and%20using%20biomass%20for%20energy> [accessed August 2020].
- EIA. 2020a. Electric Power Monthly with Data for November 2019. U.S. Energy Information Administration, DOE. https://www.eia.gov/electricity/monthly/current_month/epm.pdf [accessed February 2020].
- EIA. 2020b. Biomass Explained: Wood and Wood Waste. U.S. Energy Information Administration, DOE. https://www.eia.gov/energyexplained/index.php?page=biomass_wood [accessed February 2020].
- EIA. 2020c. Electricity Data Browser, Net Generation, United States, All Sectors, Annual. U.S. Energy Information Administration, DOE. <https://www.eia.gov/electricity/data/browser/> [accessed February 2020]. These data apply to biomass power generation from both entity-scale and utility-scale systems.
- EIA. 2020d. Wholesale Electricity and Natural Gas Market Data. U.S. Energy Information Administration, DOE. <https://www.eia.gov/electricity/wholesale/#history> [accessed March 2020].
- EIA. 2020e. Electricity Explained. U.S. Energy Information Administration, DOE. <https://www.eia.gov/energyexplained/electricity/prices-and-factors-affecting-prices.php> [accessed March 2020].
- EIA. 2020f. Glossary. U.S. Energy Information Administration, DOE. <https://www.eia.gov/tools/glossary/index.php?id=N> [accessed February 2020].
- EIA. 2020g. *Technical Notes (to Electric Power Monthly)*. U.S. Energy Information Administration, DOE. <https://www.eia.gov/electricity/monthly/pdf/technotes.pdf> [accessed February 2020].
- EIA. 2020h. Electricity Data Browser, Net Generation for Biomass, Annual. U.S. Energy Information Administration, DOE. <https://www.eia.gov/electricity/data/browser/#/topic/0?agg=1,0,2&fuel=0008&geo=vvvvvvvvvvo&sec=o3g&freq=A&start=2014&end=2018&ctype=linechart<ype=pin&rtype=s&pin=&rse=0&maptype=1> [accessed February 2020].
- EIA. 2020i. Wholesale Electricity and Natural Gas Market Data. U.S. Energy Information Administration, DOE. <https://www.eia.gov/electricity/wholesale/#history> [accessed February 2020].
- EPA. 2012a. *Waste Heat to Power Systems*. U.S. Environmental Protection Agency. https://www.epa.gov/sites/production/files/2015-07/documents/waste_heat_to_power_systems.pdf [accessed February 2020].
- EPA. 2012b. *How to Use eGRID for Carbon Footprinting Electricity Purchases in Greenhouse Gas Emission Inventories*. U.S. Environmental Protection Agency. <https://www3.epa.gov/ttnchie1/conference/ei20/session3/adiem.pdf> [accessed February 2020].
- EPA. 2017a. *Catalog of CHP Technologies*. U.S. Environmental Protection Agency. https://www.epa.gov/sites/production/files/2015-07/documents/catalog_of_chp_technologies.pdf [accessed February 2020].
- EPA. 2017b. *Anaerobic Digestion Trends and Successes in the U.S.* U.S. Environmental Protection Agency. https://www.epa.gov/sites/production/files/2017-11/documents/anaerobic-digestion-trends-and-successes-in-the-us_elger.pdf [accessed April 2020].
- EPA. 2018a. *EPA's Treatment of Biogenic Carbon Dioxide (CO₂) Emissions From Stationary Sources That Use Forest Biomass for Energy Production*. U.S. Environmental Protection Agency. https://www.epa.gov/sites/production/files/2018-04/documents/biomass_policy_statement_2018_04_23.pdf [accessed February 2020].
- EPA. 2018b. *Market Opportunities for Biogas Recovery Systems at U.S. Livestock Facilities*. U.S. Environmental Protection Agency. <https://www.epa.gov/sites/production/files/2018-06/documents/epa430r18006agstarmarketreport2018.pdf> [accessed February 2020].
- EPA. 2020a. Green Power Partnership, Renewable Energy Certificates (RECs). U.S. Environmental Protection Agency. <https://www.epa.gov/greenpower/renewable-energy-certificates-recs> [accessed February 2020].
- EPA. 2020b. *eGRID Summary Tables 2018*. U.S. Environmental Protection Agency. https://www.epa.gov/sites/production/files/2020-01/documents/egrid2018_summary_tables.pdf [accessed February 2020].
- EPA. 2020c. Greenhouse Gas Equivalencies Calculator (last updated March 2020). U.S. Environmental Protection Agency. <https://www.epa.gov/energy/greenhouse-gas-equivalencies-calculator> [accessed March 2020].
- EPA. 2020d. Greenhouse Gas Emissions: Understanding Global Warming Potentials. U.S. Environmental Protection Agency. <https://www.epa.gov/ghgemissions/understanding-global-warming-potentials> [accessed February 2020].

EPA. 2020e. *AgSTAR Project Development Handbook: A Handbook for Developing Anaerobic Digestion/Biogas Systems on Farms in the United States*. U.S. Environmental Protection Agency. <https://www.epa.gov/sites/production/files/2014-12/documents/agstar-handbook.pdf> [accessed May 2020].

EPA. 2020f. *AgSTAR Data and Trends*. U.S. Environmental Protection Agency. <https://www.epa.gov/agstar/agstar-data-and-trends#adpotential> [accessed May 2020].

EPA. 2020g. *How Does Anaerobic Digestion Work?* U.S. Environmental Protection Agency. <https://www.epa.gov/agstar/how-does-anaerobic-digestion-work> [accessed March 2020].

EPA. 2020h. *AgSTAR: Livestock Anaerobic Digester Database*. U.S. Environmental Protection Agency. <https://www.epa.gov/agstar/livestock-anaerobic-digester-database> [accessed May 2020].

EPA. 2020i. *Types of Anaerobic Digesters*. U.S. Environmental Protection Agency. <https://www.epa.gov/anaerobic-digestion/types-anaerobic-digesters> [accessed February 2020].

ETIP. 2020. *Bio-SNG Projects in Europe*. European Technology and Innovation Platform. <http://www.etipbioenergy.eu/value-chains/conversion-technologies/advanced-technologies/biomass-to-gas/bio-sng-projects-in-europe> [accessed February 2020].

Farm Bureau. 2020. *Largest Decline in U.S. Dairy Farms in 15-Plus Years in 2019*. American Farm Bureau Federation. <https://www.fb.org/market-intel/largest-decline-in-u.s.-dairy-farms-in15-plus-years-in-2019> [accessed April 2020].

HR 1865. 2019. *Further Consolidated Appropriations Act, 2020* (became Public Law 116-94 on December 20, 2019). U.S. House of Representatives Bill 1865. <https://www.congress.gov/bill/116th-congress/house-bill/1865/text> [accessed February 2020].

ICF. 2013. *Greenhouse Gas Mitigation Options and Costs for Agricultural Land and Animal Production Within the United States*. ICF International under contract to the U.S. Department of Agriculture. https://www.usda.gov/oce/climate_change/mitigation_technologies/GHG_Mitigation_Options.pdf [accessed February 2020].

IEA. 2019. *IEA Bioenergy Task 33 Country Report 2019: Thermal Biomass Gasification in Denmark*. International Energy Agency. http://ieatask33.org/app/webroot/files/file/country_reports/2019/Danish%20Country%20Report%202019%20final.pdf [accessed May 2020].

IREC. 2019. *Model Interconnection Procedures 2019*. Interstate Renewable Energy Council. <https://irecusa.org/publications/irec-model-interconnection-procedures-2019/> [accessed February 2020].

IRENA. 2012. *Renewable Energy Technologies: Cost Analysis Series: Biomass for Power Generation*. International Renewable Energy Agency. <https://www.irena.org/publications/2012/Jun/Renewable-Energy-Cost-Analysis---Biomass-for-Power-Generation> [accessed February 2020].

IRENA. 2018. *Renewable Power Generation Costs in 2017*. https://www.irena.org/-/media/Files/IRENA/Agency/Publication/2018/Jan/IRENA_2017_Power_Costs_2018.pdf [accessed February 2020].

IRS. 2019. *Instructions for Form 8835: Renewable Electricity, Refined Coal, and Indian Coal Production Credit*. Internal Revenue Service. <https://www.irs.gov/pub/irs-pdf/i8835.pdf> [accessed February 2020].

IRS. 2020. *Credit for Renewable Electricity Production, Refined Coal Production, and Indian Coal Production, and Publication of Inflation Adjustment Factors and Reference Prices for Calendar Year 2020*. <https://www.govinfo.gov/content/pkg/FR-2020-05-13/pdf/2020-10273.pdf> [accessed June 2020].

KSDOC. 2020. *Biomass-to-Energy Plant*. Kansas Department of Commerce. <https://www.kansascommerce.gov/the-kansas-edge/exemptions-financing-incentives-taxes-unemployment/taxes/biomass-to-energy-plant/> [accessed February 2020].

Lazard. 2017. *Lazard's Levelized Cost of Energy Analysis—Version 11.0*. <https://www.lazard.com/media/450337/lazard-levelized-cost-of-energy-version-110.pdf> [accessed February 2020].

Los Angeles Times. 2017. *What All Those Dead Trees Mean for the Sierra Nevada*. <https://www.latimes.com/local/california/la-me-sierra-dead-trees-20170128-story.html> [accessed February 2020].

NARA. 2020. *Rural Energy Savings Program*, as published in the *Federal Register*, Vol. 85, No. 64, April 2, 2020. National Archives and Records Administration. <https://www.govinfo.gov/content/pkg/FR-2020-04-02/pdf/2020-06215.pdf> [accessed April 2020].

NASEO. 2020. *The 2020 U.S. Energy and Employment Report*. National Association of State Energy Officials and Energy Futures Initiative. <https://static1.squarespace.com/static/5a98cf80ec4eb7c5cd928c61/t/5ee78423c6fcc20e01b83896/1592230956175/USEER+2020+0615.pdf> [accessed June 2020].

NCCETC. 2015a. *Biomass Sales and Use Tax Exemption*. NC Clean Energy Technology Center. <https://programs.dsireusa.org/system/program/detail/1952> [accessed May 2020].

- NCCETC. 2015b. Biomass Energy Tax Credit (Corporate). NC Clean Energy Technology Center. <https://programs.dsireusa.org/system/program/detail/1805> [accessed May 2020].
- NCCETC. 2016. Biomass Equipment & Materials Compensating Tax Deduction. NC Clean Energy Technology Center. <https://programs.dsireusa.org/system/program/detail/359> [accessed May 2020].
- NCCETC. 2018. Modified Accelerated Cost-Recovery System (MACRS). NC Clean Energy Technology Center. <https://programs.dsireusa.org/system/program/detail/676> [accessed March 2020].
- NCCETC. 2020a. Business Energy Investment Tax Credit (ITC). NC Clean Energy Technology Center. <http://programs.dsireusa.org/system/program/detail/658> [accessed February 2020].
- NCCETC. 2020b. DSIRE®. NC Clean Energy Technology Center. <https://www.dsireusa.org/> [accessed February 2020].
- NIBS. 2016. *Whole Building Design Guide, Biomass for Electricity Generation*. National Institute of Building Sciences. <https://www.wbdg.org/resources/biomass-electricity-generation> [accessed February 2020].
- NREL. 2009. *Market Assessment of Biomass Gasification and Combustion Technology for Small- and Medium-Scale Applications*. National Renewable Energy Laboratory. <https://www.nrel.gov/docs/fy09osti/46190.pdf> [accessed February 2020].
- NREL. 2011. *A Review of Operational Water Consumption and Withdrawal Factors for Electricity Generating Technologies*. National Renewable Energy Laboratory. <https://www.nrel.gov/docs/fy11osti/50900.pdf> [accessed August 2020].
- NREL. 2013. *Feasibility Study of Anaerobic Digestion of Food Waste in St. Bernard, Louisiana*. National Renewable Energy Laboratory. <https://www.nrel.gov/docs/fy13osti/57082.pdf> [accessed February 2020].
- NREL. 2014a. Solid Biomass Resources in the United States. National Renewable Energy Laboratory. <https://www.nrel.gov/gis/assets/images/national-biomass-total-2014-01.jpg> [accessed February 2020].
- NREL. 2014b. Biomass Resource Data, Tools, and Maps. National Renewable Energy Laboratory. <https://www.nrel.gov/gis/biomass.html> [accessed February 2020].
- NREL. 2016. Distributed Generation Renewable Energy Estimate of Costs. National Renewable Energy Laboratory. <https://www.nrel.gov/analysis/tech-lcoe-re-cost-est.html> [accessed March 2020].
- NREL. 2019. Annual Technology Baseline: Electricity, Biopower. National Renewable Energy Laboratory. <https://atb.nrel.gov/electricity/2019/index.html?t=cb> [accessed March 2020].
- NREL. 2020. Net Metering. National Renewable Energy Laboratory. <https://www.nrel.gov/state-local-tribal/basics-net-metering.html> [accessed February 2020].
- NSAC. 2019. Biomass Crop Assistance Program. National Sustainable Agriculture Coalition. <https://sustainableagriculture.net/publications/grassrootsguide/renewable-energy/biomass-crop-assistance-program/> [accessed February 2020].
- NYSERDA. 2014. *Anaerobic Digester Business Model and Financing Options for Dairy Farms in New York State*. New York State Energy Research and Development Authority. <https://www.nysersda.ny.gov/About/Publications/Research-and-Development-Technical-Reports/Clean-Power-Innovation-Reports> [accessed February 2020].
- OMB. 2020. Treatment of Biogenic CO2 Emissions Under the Clean Air Act Permitting Programs. U.S. Office of Management and Budget. <https://www.reginfo.gov/public/do/eAgendaViewRule?pubId=202004&RIN=2060-AU03> [accessed August 2020].
- PG&E. 2020. *Frequently Asked Questions: PG&E BioMAT Feed-in Tariff Program*. Pacific Gas and Electric Company. https://www.pge.com/includes/docs/pdfs/b2b/wholesaleelectricssolicitation/BioMAT/BioMAT_Webpage_FAQs.pdf [accessed February 2020].
- Power Stations of the UK. 2020. Drax Power Station, North Yorkshire. <http://www.powerstations.uk/drax-power-station-north-yorkshire/> [accessed February 2020].
- Power Technology. 2020. Gainesville Renewable Energy Center. <https://www.power-technology.com/projects/gainesville-center/> [accessed February 2020].
- PRWeb. 2017. Two Phoenix Energy Projects, Developing a Total of 5MW of Biomass Power Generation, Receive Offers for PPAs From Pacific Gas and Electric. <https://www.prnewswire.com/news-releases/two-phoenix-energy-projects-developing-a-total-of-5mw-of-biomass-power-generation-receive-offers-for-ppas-from-pacific-gas--electric-300547866.html> [accessed February 2020].
- Penn State. 2012. Fate of Nutrients and Pathogens During Anaerobic Digestion of Dairy Manure. Pennsylvania State University Extension, College of Agricultural Sciences. <https://extension.psu.edu/fate-of-nutrients-and-pathogens-during-anaerobic-digestion-of-dairy-manure> [accessed May 2020].
- SERI. 1979. *A Survey of Biomass Gasification, Volume II: Principles of Gasification*. Solar Energy Research Institute. <https://www.nrel.gov/docs/legosti/old/239-2.pdf> [accessed February 2020].

Stephens, et al. 2018. Drought, Tree Mortality, and Wildfire in Forests Adapted to Frequent Fire. *Bioscience*, Volume 68, Issue 2. Stephens, S., Collins, B., Fettig, C., Finney, M., Hoffman, C., Knapp, E., North, M., Safford, H., & Wayman, B. <https://academic.oup.com/bioscience/article/68/2/77/4797261> [accessed June 2020].

USAID. 2019. *Clean Energy Emission Reduction (CLEER) Protocol*. U.S. Agency for International Development. https://www.cleertool.org/Files/Calculators/CLEER_Protocol_May_2019.pdf [accessed February 2020]. USAID data are based on Intergovernmental Panel on Climate Change's 2006 Guidelines.

USDA. 2007. *An Analysis of Energy Production Costs From Anaerobic Digestion Systems on U.S. Livestock Production Facilities*. U.S. Department of Agriculture. <https://directives.sc.egov.usda.gov/OpenNonWebContent.aspx?content=22533.wba> [accessed May 2020].

USDA. 2014a. *Assessment of the National Prospects for Electricity Generation From Biomass*. U.S. Department of Agriculture. https://www.usda.gov/oce/reports/energy/USbiopower_04_2014.pdf [accessed February 2020].

USDA. 2014b. *USDA Selects 36 Energy Facilities to Accept Biomass Deliveries*. U.S. Department of Agriculture. <https://www.usda.gov/media/press-releases/2014/07/23/usda-selects-36-energy-facilities-accept-biomass-deliveries> [accessed April 2020].

USDA. 2016a. *Fact Sheet: Biomass Crop Assistance Program for Fiscal Year 2017*. U.S. Department of Agriculture. https://www.fsa.usda.gov/Assets/USDA-FSA-Public/usdafilles/FactSheets/archived-fact-sheets/bcap_fact_sheet_nov2016.pdf [accessed February 2020].

USDA. 2016b. *Trends in U.S. Agriculture's Consumption and Production of Energy: Renewable Power, Shale Energy, and Cellulosic Biomass*. U.S. Department of Agriculture. https://www.ers.usda.gov/webdocs/publications/74658/60128_eib159.pdf?v=0 [accessed February 2020].

USDA. 2019a. *2019 Bark Beetle Forecast for California, Oregon and Washington*. U.S. Department of Agriculture. https://www.fs.usda.gov/Internet/FSE_DOCUMENTS/fseprd573081.html [accessed February 2020].

USDA. 2019b. *Fact Sheet: High Energy Cost Grants*. U.S. Department of Agriculture. https://www.rd.usda.gov/sites/default/files/fact-sheet/508_RD_FS_RUS_HighEnergyCosts.pdf [accessed February 2020].

USDA. 2019c. *2019 High Energy Cost Grant Awardees*. U.S. Department of Agriculture. <https://www.rd.usda.gov/programs-services/high-energy-cost-grants> (at "To Apply" tab) [accessed February 2020].

USDA. 2019d. *Fact Sheet: Rural Energy for America Program, Renewable Energy & Energy Efficiency*. U.S. Department of Agriculture. https://www.rd.usda.gov/sites/default/files/fact-sheet/508_RD_FS_RBS_REAP_RE.pdf [accessed February 2020].

USDA. 2019e. *Fact Sheet: Rural Energy for America Program (REAP) Energy Audit and Renewable Energy Development Assistance Grants*. U.S. Department of Agriculture. https://www.rd.usda.gov/sites/default/files/fact-sheet/508_RD_FS_RBS_REAP_EA.pdf [accessed February 2020].

USDA. 2019f. *USDA Forest Service 2020 Wood Innovation Grant, Region 5 Informational Webinar*. U.S. Department of Agriculture. <https://ucanr.edu/sites/WoodyBiomass/files/315811.pdf> [accessed February 2020].

USDA. 2019g. *U.S. Forest Service FY20 Budget Justification*. U.S. Department of Agriculture. <https://www.obpa.usda.gov/27forest2020notes.pdf> [accessed February 2020].

USDA. 2019h. *Wood Waste Helps Keep the Lights on in Rural Communities*. U.S. Department of Agriculture. <https://www.usda.gov/media/blog/2019/10/21/wood-waste-helps-keep-lights-rural-communities> [accessed April 2020].

USDA. 2019i. *Types of Anaerobic Digesters*. USDA Cooperative Extension Program. U.S. Department of Agriculture. <https://farm-energy.extension.org/types-of-anaerobic-digesters/> [accessed March 2020].

USDA. 2020a. *High Energy Cost Grants*. U.S. Department of Agriculture. <https://www.rd.usda.gov/programs-services/high-energy-cost-grants> [accessed February 2020].

USDA. 2020b. *Rural Energy for America Program Renewable Energy Systems & Energy Efficiency Improvement Guaranteed Loans & Grants*. U.S. Department of Agriculture. <https://www.rd.usda.gov/programs-services/rural-energy-america-program-renewable-energy-systems-energy-efficiency> [accessed February 2020].

USDA. 2020c. *Wood Energy (WE): Funded Projects by Fiscal Year*. U.S. Department of Agriculture. <https://www.fs.usda.gov/naspf/programs/wood-education-and-resource-center/wood-energy-we> [accessed February 2020].

UVM. 2008. *On-Farm Energy Case Study: Outdoor Wood Boiler for Greenhouse and Farmstead Heat*. The University of Vermont Extension. <https://www.uvm.edu/vtvegandberry/Pubs/OutdoorWoodBoilerGreenhouseFarmsteadHeat.pdf> [accessed April 2020].

WEF. 2017. *Anaerobic Digestion Fundamentals*. Water Environment Federation. <https://www.wef.org/globalassets/assets-wef/direct-download-library/public/03---resources/wsec-2017-fs-002-mrrdc-anaerobic-digestion-fundamentals-fact-sheet.pdf> [accessed February 2020].



Zullo. 2016. *Anaerobic Digestion Industry Overview and Opportunities for Process Intensification*. Zullo, Luca, VerdeNero, LLC. Posted by Advanced Research Projects Agency – Energy, DOE. https://arpa-e.energy.gov/sites/default/files/LucaZullo_AD_Industry.pdf [accessed February 2020].

4. Solar Energy

INTRODUCTION

Solar photovoltaic (PV) generation has experienced the most rapid growth over the past decade compared with other renewable electricity technologies. At all scales, from small systems on homes to mid-sized systems on farms and other businesses to the largest systems that can cover 500 or more acres of rural land, PV has expanded from a minor part of the U.S. generation mix to one of the biggest sources of new power construction. This technology, which converts sunlight into electricity, has grown in the United States from 71 megawatts (MW) of alternating current (AC) capacity (MW_{AC}) in 2008 to 58,782 MW_{AC} in 2019, an 800-fold increase (EIA, 2020a, table 6.1.A; EIA, 2019a).

In the PV industry, three distinct market segments exist: residential, commercial and industrial, and utility-scale systems. Residential, commercial, and industrial customer PV systems (collectively called “entity-scale” in this report) are smaller than utility-scale systems and can be implemented by rural households or individual farms and other agricultural or forestry businesses to directly reduce their electricity costs. Entity-scale systems comprise 39 percent (23,211 MW_{AC}) of the total U.S. PV market on a capacity basis, while utility-scale systems represent 61 percent (35,571 MW_{AC}) of the market (EIA, 2020a, table 6.1.A).^{113,114} Exhibit 4-1 shows the growth of these two market segments, with utility-scale systems increasing more rapidly in the past 4 years.

EXHIBIT 4-1: Cumulative U.S. PV Generating Capacity by Segment (MW_{AC})

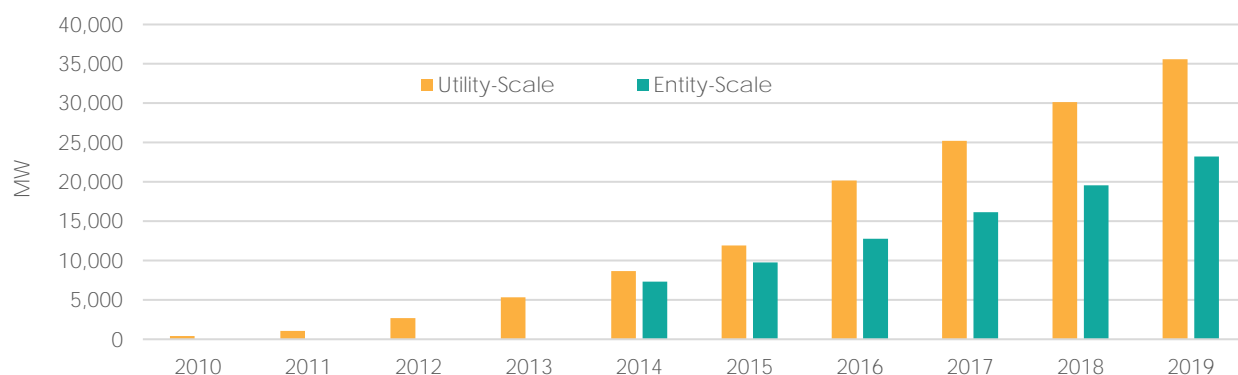

Source: Adapted from EIA, 2020a, table 6.1.A.

The six most important themes about PV technologies for the U.S. agricultural and forestry sectors and rural America are the following:

1. PV is a mature technology, which can be readily installed in numerous sites at farms and rural households and businesses, including rooftops, flat-ground surfaces, and parking canopies.
2. Capital costs have dropped sharply since 2010: 63 percent for residential-scale, 66 percent for commercial-scale, and 77 percent for utility-scale (fixed-tilt) systems on inflation-adjusted bases (NREL, 2018a, pp. 21, 27, and 37).
3. Improving economics, largely due to declining capital costs from economies of scale and technological advancements, have led to substantial growth in PV adoption.
4. Federal and State incentives have played important roles in accelerating PV adoption by reducing net system costs and increasing revenues from system operation.

¹¹³ The U.S. Energy Information Administration's (EIA) designation of “small-scale” PV is used as equivalent to “entity-scale” in this report. EIA began reporting “small-scale” systems in 2014. See EIA, 2020b for more information on EIA categorization and estimation methods.

¹¹⁴ Among EIA small-scale PV system capacity in the fourth quarter of 2019, 61 percent (14,229 MW) is in the residential sector, 31 percent (7,186 MW) is in the commercial sector, and 8 percent (1,796 MW) is in the industrial sector (EIA, 2020c, table 8b).

5. PV adoption is not uniform. Differences in available sunlight, retail and wholesale prices for solar power, and PV incentives cause widely different regional adoption patterns.
6. Perhaps the greatest challenge to extending PV growth in the next 5 years is whether the decline in Federal incentives beginning in 2020 will impede investment in PV since it may result in higher net costs of adoption in comparison with recent years.

These six themes are explored in this chapter, which has the following sections:

- A technical characterization of the technology and how it operates
- A summary of the deployment level and costs of PV systems, and how adoption of these systems differs by region
- A description of the potential economic, environmental, and land use impacts of PV adoption on farms, rural households, and others
- An explanation of how self-ownership vs. third-party ownership models have played out for PV
- A profile of battery energy storage technologies¹¹⁵
- Profiles of solar water and air heating technologies¹¹⁶
- An overview of the challenges to continued growth in solar adoption

“Solar power” encompasses numerous technologies, and this chapter does not try to describe each in detail. The emphasis here is on on-grid applications of PV technology that substitute solar electricity for conventional electricity from the utility grid.

Off-grid applications that do not receive power from a utility are a much smaller part of the PV market. Across the entire U.S. PV market, the total capacity of off-grid PV systems exceeded on-grid systems until 2004; however, “the grid-connected market has since dominated” (DOE, 2010, pp. 6–7). Similarly, until the early 2000s, off-grid PV systems were more prevalent than on-grid systems in agricultural applications (USDA, 2013, p. 3). Common off-grid applications include water pumping for irrigation and livestock, electric fencing, and lighting (USDA, 2011, p. 15).

Because they are technologically similar in components, design, and function to on-grid applications, off-grid systems are not separately profiled in this report.

TECHNOLOGY CHARACTERIZATION OF PV

This section provides an overview of how PV systems are designed and operate. Because entity-scale (residential, commercial, and industrial) and utility-scale technologies are similar, much of the description is in relation to residential applications and is not repeated.

Technology Configuration and Operation

The key components of PV systems are:

- Solar panels (also called “modules”) that convert sunlight to direct current (DC) electricity¹¹⁷;
- Racking systems to hold and help secure the panels to the rooftop (or another surface), and that can have a fixed axis or rotate to track the sun throughout the day;

¹¹⁵ Battery energy storage technologies are included because they are increasingly being combined with PV systems.

¹¹⁶ For more information on solar thermal technologies beyond solar water and air heating (e.g., concentrating solar power [CSP] and solar air cooling), see EPA, 2020a and SEIA, 2020a. CSP is a technology that reflects sunlight into a small area at very high temperatures, with the heat used directly, stored, or converted to electricity via turbines or heat engines. The economics of CSP are more challenging than PV, and that technology is not commonly deployed in the United States. Most CSP capacity in the United States is in utility-scale projects in desert areas of the Southwest. CSP is largely excluded from this report because it is much less prevalent than PV. For example, through 2018, approximately 1,800 MW of CSP capacity has been installed in the United States, compared with more than 49,000 MW of PV capacity (EIA, 2019a; NREL, 2019a, p. iv). Like CSP, solar air cooling has a far smaller market in the United States than PV and is excluded from this report.

¹¹⁷ The most common types of PV panels are crystalline-silicon and thin-film. For a comparison of these module types, see USDA, 2011, pp. 10–11.

- Inverters that convert DC power from the panels to alternating current (AC) that can be used by the household or business hosting the PV project¹¹⁸; and
- **“Balance of systems” equipment**, including conduit, wiring, disconnect switches, and a monitoring system.

Solar panels typically have 250 to 405 watts of total capacity (i.e., the ability to produce up to 405 watts of DC power under laboratory conditions). Each panel is comprised of smaller units called “cells” that perform the conversion of sunlight to power. There usually are 60 to 100 connected cells in a residential panel. Most residential PV systems have 10 to 30 panels mounted on a rooftop via a racking system, which are wired to an inverter inside the house.¹¹⁹ The AC power from the inverter is directly connected to the household electrical system and can be used by any electricity-consuming equipment inside the house as a replacement for utility grid power. Excess solar power produced, beyond what is instantaneously consumed at the home, is typically exported to the utility grid. If a battery storage device is integrated with the system, the excess power can be stored in the battery for future use.

EXHIBIT 4-2: How a Typical, Grid-Connected Rooftop Residential PV System Operates

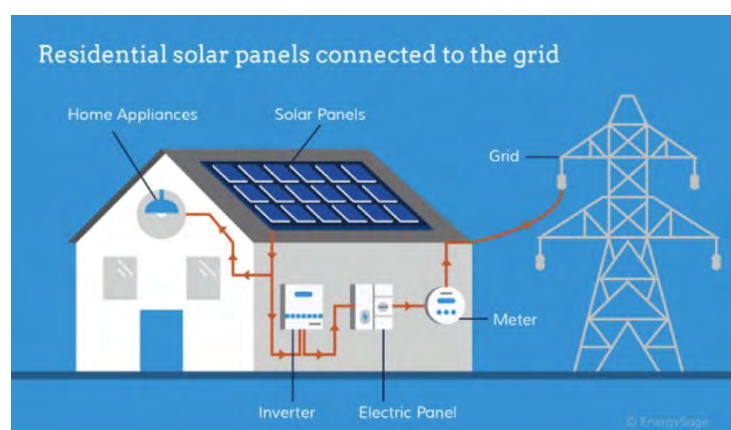

Source: Idaho, 2021.

connected residential PV system is shown in *exhibit 4-2*.

Typical on-grid PV systems, for safety reasons, shut off within milliseconds of a utility grid power outage. Therefore, they will not provide emergency backup power.¹²⁰ When battery storage is paired with PV, on-grid systems can be configured more easily to safely operate as power islands, serving a home or business during utility outages without posing a danger to utility line workers or firefighters. In contrast, utility outages do not affect off-grid systems, which is a main technical difference from on-grid PV systems.

A schematic of a representative grid-

The basic design and components of commercial PV systems¹²¹ closely follow those of residential systems. PV is a modular technology, hence larger commercial systems on rooftops have more modules than smaller residential installations (and somewhat larger modules). Commercial systems, however, tend to be mounted on the ground much more frequently than household systems.¹²²

¹¹⁸ For some off-grid PV systems, there may not be an inverter if all intended uses only require DC power.

¹¹⁹ In an alternative configuration, there may be several smaller “micro-inverters” wired under the panels instead of a central inverter.

¹²⁰ There are rare exceptions in which a PV-only system is specially configured to operate when grid power is absent.

¹²¹ PV systems for commercial and industrial customers are essentially the same and are labeled as “commercial” or “commercial-scale” systems throughout this chapter.

¹²² For example, 52 percent of commercial-scale PV systems greater than 100 kW_{DC} in capacity are ground-mounted, while 17 percent of smaller (up to 100 kW_{DC}) commercial-scale systems are ground-mounted, as are 3 percent of residential systems (LBNL, 2019a, p. 2). In addition to ground-mounted and roof-mounted installations, PV systems are mounted on parking canopies (raised metal structures above parking spaces) or light poles.

Fixed-Tilt vs. Tracking Systems

Because PV is a modular technology, even the largest utility-scale systems have the same types of components as small, entity-scale systems. Beyond size, the main technology differences are that utility-scale systems are almost exclusively ground-mounted and often rely on single-axis or dual-axis “tracking” mechanisms. These tracking mechanisms rotate the panels during the day to follow the sun’s path and thereby increase solar electricity production.¹²³ As seen in exhibit 4-3, more than 70 percent of U.S. utility-scale systems in recent years have tracking capability. The differences in the technical operation of single- and dual-axis trackers compared with fixed-tilt systems is displayed in exhibit 4-4.

EXHIBIT 4-3: Prevalence of Single- or Dual-Axis Tracking Among Utility-Scale PV Systems

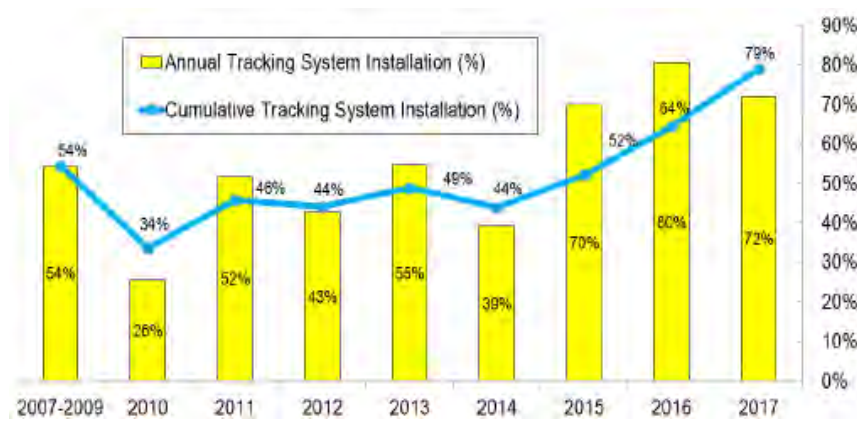

Source: NREL, 2018a, p. 33.

EXHIBIT 4-4: Operational Distinctions Between Fixed-Tilt and Tracking PV Systems

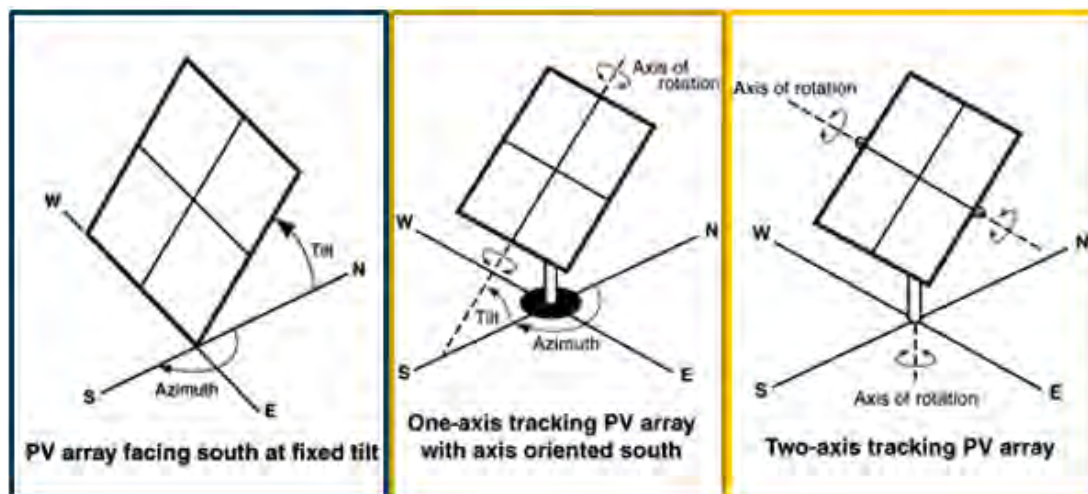

Source: EIA, 2017.

Commercial-scale PV systems that are *ground-mounted* on farms may also use tracking mechanisms. However, tracking technologies are not generally appropriate for *rooftop* PV systems, either commercial or residential. This is because the increased capital and maintenance costs of tracking systems, compared with fixed-tilt systems, are not justified by the typically small sizes of rooftop PV installations. Tracking systems also introduce greater engineering complexities on rooftop sites compared with ground-mounted sites.

¹²³ In contrast, almost all entity-scale (i.e., residential and commercial) PV systems forego the added cost and complexity of tracking mechanisms and rely on fixed-tilt (also called “fixed-axis”) configurations.

Technology Examples

A photo of a rural PV system at residential scale is shown in *exhibit 4-5*. While many commercial PV systems are installed on pitched (angled) roofs like residential systems, commercial systems are also regularly mounted on flat roofs (see the agricultural building example in *exhibit 4-6*), the ground (see the rural business example in *exhibit 4-7*), and on parking canopies.

Land Use Requirements

Rooftop or Parking Canopy PV Systems

PV systems that generate a kilowatt of DC (kW_{DC}) power typically require about 100 square feet of shade-free and otherwise unobstructed area (often on a rooftop).¹²⁴ Therefore, a $5-kW_{DC}$ PV system would require 500 square feet before accounting for setbacks from the roof edge and possible pathways for fire safety.

Off-grid PV systems have comparable space requirements. Instead of using solar power to replace grid electricity, off-grid PV installations serve uses that often do not have ready access to grid power, such as water irrigation, pond aeration, and remote communications in agriculture.¹²⁵

Ground-Mounted PV Systems

Land use requirements for fixed-tilt and tracking utility-scale systems up to $20 MW_{AC}$ in capacity are summarized in *exhibit 4-8*.¹²⁶ Because they require more separation between rows of panels to avoid self-shading, tracking systems occupy more land than fixed-tilt systems.

EXHIBIT 4-8: Land Use Requirements for Utility-Scale PV Systems (in acres per MW_{AC} of capacity)

	Fixed-Tilt	Single-Axis Tracking	Dual-Axis Tracking
Direct Land Area	5.5	6.3	9.4
Total Land Area	7.6	8.7	13

Source: NREL, 2013, p. 10.

EXHIBIT 4-5: Rural Rooftop PV System in Schoharie County, New York



Source: NYSDERDA, 2015, p. 5.

EXHIBIT 4-6: Commercial Rooftop PV System on an Agribusiness in Vermont



Source: Vermont, 2020.

EXHIBIT 4-7: Ground-Mounted PV System Near a Rural Business in Tippecanoe County, Indiana



Source: USDA, 2017.

¹²⁴ See, for example, SDG&E, n.d., p. 4. The ratio of DC to AC capacity in entity-scale PV systems typically ranges from 1:1 to 1.4:1 (LBNL, 2019a, p. 13). At a ratio of 1.25:1, a $5-kW_{DC}$ PV system would be equivalent to a $4-kW_{AC}$ system.

¹²⁵ These off-grid applications often can use DC power directly and avoid the cost and power losses of inverters that convert electricity from DC to AC power (USDA, 2010, p. 11). For additional information on agricultural off-grid PV uses, see USDA, 2011.

¹²⁶ "Direct land area" describes the land covered by the PV system panels and associated infrastructure, while "total land area" describes the entire site for the PV project as delineated on system blueprints (NREL, 2013, p. 2).

The land use requirements of utility-scale PV systems, in agricultural communities in particular, have led to increasing interest in low-impact site development plans. Such plans differ from traditional PV development plans in their attention to preserving topsoil and planting vegetation that is conducive to pollinators and other insects favorable to agriculture at nearby farms (NREL, 2019b).¹²⁷ Exhibit 4-9 shows a pollinator-conducive PV system. There is also interest in “dual-use” implementation of PV, which explicitly integrates farm and energy activities (UMass, 2018). Although full dual-use PV systems are not yet common, systems are being deployed and studied in Massachusetts, New York, Vermont, and elsewhere (see, for example, Cornell University, 2018 and UVM, 2018).

EXHIBIT 4-9: Example of a Utility-Scale PV System With Pollinator Vegetation



CURRENT LEVEL AND COST OF ADOPTION AND REGIONAL DISTINCTIONS FOR PV

While PV adoption continues to grow strongly, there is not a single, uniform PV market across the United States, just as there is not a single national market for wind power nor electricity in general. Instead, the United States has a conglomeration of State and regional markets. Overall PV deployment (from entity- and utility-scale systems combined) in some States (including California, Hawaii, Massachusetts, and Vermont) exceeds 15 percent of all power generation capacity, while in other States (including Alabama, Iowa, Kentucky, and Washington) PV deployment represents less than 1 percent of total capacity.¹²⁸

The differences in regional and State deployment of PV systems are related to the differences in four factors that drive the economics of investing in, or purchasing electricity from, PV systems. These factors are described in the sub-sections that follow:

1. Solar resource
2. Capital and operating costs
3. Grid (retail and wholesale) power prices
4. Financial incentive policies

Solar Resource

The amount of sunlight available for solar electricity production varies among the 50 States, with the highest levels being in the Desert Southwest, Florida, and Hawaii, and the lowest levels being in Alaska, followed by the Upper Great Lakes, New England, and a corner of the Pacific Northwest. Exhibit 4-10 displays solar resources across all States, with darker areas representing more abundant resources.

On an output basis, a rooftop PV system in Southern California or Arizona produces roughly 25 percent to 35 percent more electricity annually than a similarly configured system in Massachusetts or New Jersey (NREL, 2020).¹²⁹ However, just because solar resources may be lower than average in a given State does not mean that PV will be a poor economic investment, whether for farms, forestry operations, other businesses, or households in that State. The other drivers discussed in this section can more than compensate for a relatively low solar resource in many locations. The opposite is also true—having relatively abundant sunlight does not guarantee a cost-effective PV system, even with PV capital costs being much lower now than in the past.

¹²⁷ For more information on the establishment and management of pollinator-friendly native seed plantings in association with ground-mounted PV systems, see Michiana, 2020.

¹²⁸ Data are based on EIA, 2020a, table 6.2.B for State solar capacity and EIA, 2019b for overall State generating capacity.

¹²⁹ Calculations were performed for residential PV systems in San Bernardino, CA; Tucson, AZ; Boston, MA; and Trenton, NJ.

EXHIBIT 4-10: Solar Resources Available for PV Production Across the United States

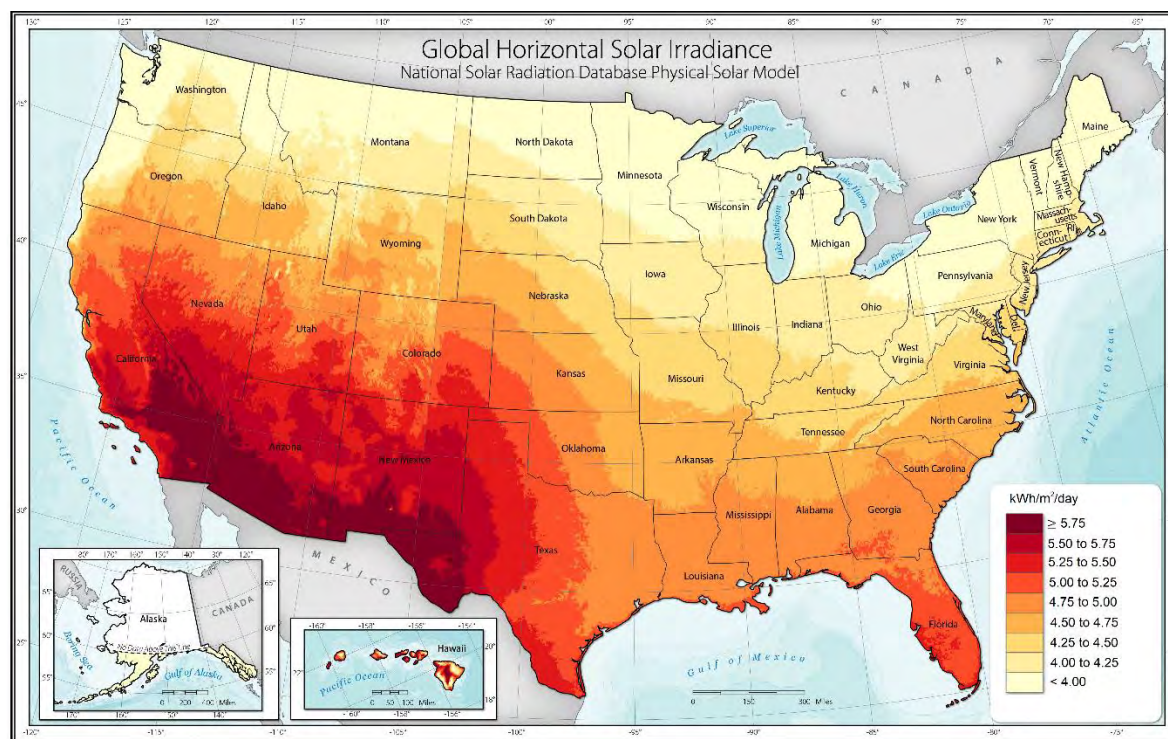

This map provides annual average daily total solar resource using 1998-2016 data (PSM v3) covering 0.038-degree latitude by 0.038-degree longitude (nominally 4 km x 4km).

Source: Adapted from NREL, 2018b.

Capital and Operating Costs

National Overview of Costs

The recent increase in PV adoption is primarily the result of decreasing capital costs. On an inflation-adjusted basis, capital costs for residential-, commercial-, and utility-scale (fixed-tilt) PV systems were, as of 2018, about 37 percent, 34 percent, and 23 percent of their respective 2010 levels (NREL, 2018a, pp. 21, 27, and 37).¹³⁰ This means that utility-scale systems experienced the greatest cost declines, dropping by 77 percent over that period.

In many parts of the country, this decline in costs has made PV a cost-effective alternative to conventional grid power for households, farms, and other organizations. For example, a 2016 study calculated that 19 States (and the District of Columbia) had already reached “grid parity” (i.e., costs that are the same or less than conventional grid power) for residential PV, and another 22 States could reach grid parity by 2020 (GTM Research, 2016).

Because sunlight is available free of charge, and because PV systems have low operation and maintenance (O&M) costs, capital cost (or “installed cost”) tends to be the most significant cost

¹³⁰ The utility-scale data point corresponds to fixed-tilt systems. Cost declines for utility-scale, single-axis tracking systems were even larger than the 77 percent decline for fixed-tilt systems at that scale.

consideration in decisions on whether to adopt. *Exhibit 4-11* lists representative capital and O&M costs for on-grid PV systems.^{131,132,133,134} Capital costs are pre-incentive.

EXHIBIT 4-11: Summary of PV Capital and O&M Costs

PV System Scale	Unit Capital Cost in \$/kW _{DC} (pre-incentive)	Typical System Size (kW _{DC})	Total Capital Cost (pre-incentive)	Annual Fixed O&M Cost in \$/kW (in year 1 of system operation)
Residential-Scale	\$3,500 – \$4,200	3–10	\$12,600 – \$35,000	\$14 – \$25
Commercial-Scale	\$2,200 – \$3,000	10–1,000	\$30,000 – \$2,200,000	\$15 – \$20
Utility-Scale	\$1,140	> 5,000	\$5,700,000+	\$9 – \$12

Sources: LBNL, 2019a, p. 27 (for residential- and commercial-scale capital costs); NREL, 2019c, p. 43 (for utility-scale capital costs); Lazard, 2019, p. 16 (for O&M costs).

The next three sub-sections of this chapter provide additional details on PV capital costs, O&M costs, and the levelized cost of energy (LCOE), which is a metric that incorporates lifetime costs and performance.

National Capital Costs

Capital costs for PV systems shown in *exhibit 4-11* include the full cost of designing, engineering, purchasing equipment, permitting, financing, and installing the PV systems, and are before accounting for any related financial incentives that may be available to households, farms, or other businesses. PV systems tend to be operational for 25 to 30 or more years, so the initial capital costs are typically amortized over this expected asset life in long-term investment calculations (e.g., net present value).

Regional Distinctions in Capital Costs

As shown in *exhibit 4-12*, capital costs, measured in dollars per watt installed, vary widely by State. Although the chart focuses on commercial-scale projects (separated into systems at or below 100 kW in capacity on the left side [“small non-residential”] and greater than 100 kW on the right [“large non-residential”]), similar spreads exist for residential-scale and utility-scale PV systems (see LBNL, 2019a, p. 29 for residential-scale, and NREL, 2018a, p. 35 for utility-scale).

For the smaller commercial systems, costs tend to be highest on a per watt basis in Minnesota, Rhode Island, and Massachusetts, and lowest in Washington, Florida, and Wisconsin. There are many potential causes for price differences. For example, the Made in Minnesota solar incentive program encouraging use of PV equipment manufactured in-State may increase costs in that market (MNDOC, 2020; LBNL, 2019a, p. 28). State differences in sales tax exemptions for PV systems and the likelihood of using premium (high-efficiency) panels in a given State also may explain some of the cost variation (LBNL, 2019a, pp. 28–29).

¹³¹ Due to economies of scale, systems at the high end of each “typical system size” range are associated with the low end of the “unit capital cost” ranges shown and vice versa.

¹³² The additional cost of integrating batteries into PV systems varies widely, and also depends on the ratio of power or peak capacity (kW) to energy (kWh) in the battery system. For a relevant analysis, see NREL, 2017, pp. vi–vii. That report notes that adding batteries can increase overall PV + battery system capital costs on residential scale systems by 75 percent or more (pre-incentive), although battery costs have decreased in the 2 years since that study was published. Additional information on battery energy systems is in a section near the end of this chapter.

¹³³ The range in the “total capital cost” in *exhibit 4-11* is established by the product of the low end of the “typical system size” and the high end of the “unit capital cost” (for the smallest PV systems), and the product of the high end of the “typical system size” and the low end of the “unit capital cost” (for the largest PV systems).

¹³⁴ For comparison with the capital cost data in *exhibit 4-11*, Lazard assumes residential PV costs for a 5-kW system at \$2,800 to \$2,950/kW, commercial-scale costs at \$1,750 to \$2,950/kW for a 1,000-kW (1-MW) system, and utility-scale costs at \$900 to \$1,100/kW for a 100,000-kW (100-MW) system (Lazard, 2019, p. 16).

EXHIBIT 4-12: Variance in Commercial (i.e., Non-Residential) PV Capital Costs by State

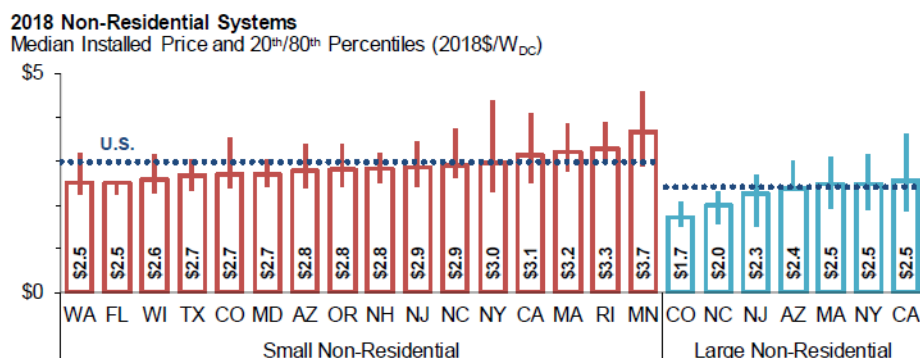

Notes: Median installed prices are shown only if at least 20 observations are available for a given state.

Source: LBNL, 2019a, p. 29.¹³⁵

Operations and Maintenance (O&M) Costs

For PV systems, O&M costs are a much less significant economic factor than capital costs, although it is still a meaningful topic to understand and include in consideration of any PV system.

PV O&M costs cover activities such as periodic inspection and cleaning of solar panels to enhance performance, replacement of damaged or under-performing panels and inverters, monitoring system performance, and responding to PV system outages and emergencies. Depending on the methodology used, some O&M cost metrics also include incremental annual property taxes and insurance premiums associated with a PV system.¹³⁶

Estimated annual, fixed O&M costs for a residential PV system are \$14 to \$25/kW-year (Lazard, 2019, p. 16). This cost translates into an annual O&M cost of \$70 to \$125 for a 5-kW system. For a commercial-scale PV system, the corresponding figures are \$15 to \$20/kW-year, and they are \$9 to \$12/kW-year for a utility-scale system (Lazard, 2019, p. 16). These costs typically rise each year with general price inflation.

Levelized Cost of Energy (LCOE)

LCOE is a useful metric for comparing electricity generation technologies that combines capital costs, O&M costs, performance (system output efficiency), and risk-adjusted expected investment returns.

LCOE also has the advantage of being expressed on a dollars per kilowatt-hour (kWh) basis that is straightforward for electricity

EXHIBIT 4-13: Estimated LCOE for PV Systems

	LCOE Range (\$/kWh)	
	Without Federal Incentives	With Federal Incentives
Residential-Scale	\$0.151 – \$0.242	\$0.139 – \$0.222
Commercial-Scale	\$0.075 – \$0.154	\$0.069 – \$0.141
Utility-Scale	\$0.032 – \$0.044	\$0.031 – \$0.042

Source: Lazard, 2019, p. 3.

¹³⁵ Data are shown for States with the greatest number of PV systems in each size category.

¹³⁶ Occasionally, O&M cost metrics also include accrual for replacement of the inverter at the end of its warranty period (typically 10 to 20 years). If this is not included in an O&M metric, it is an additional cost that potential adopters need to consider.

customers to understand.¹³⁷ *Exhibit 4-13* summarizes LCOE for PV systems of various scales.^{138,139} The economies of scale in the PV market are evident in the exhibit—the LCOE of utility-scale systems is less than half as high as commercial systems, and less than one-quarter as high as residential systems.

Grid (Retail and Wholesale) Power Prices

The price that owners receive from the system's output is as important as the cost of deploying a PV system (discussed immediately above). Depending on the type of PV system, it may receive retail or wholesale prices for its electricity output.¹⁴⁰ These prices can vary from less than \$0.03/kWh at wholesale to \$0.17/kWh and higher at retail, depending on market type and location.

Retail power is purchased by the ultimate electricity end-user (e.g., household or business consumer) and is typically associated with entity-scale PV systems. When PV systems are connected to farm, rural household, or other electricity end-user utility meters, output from the PV system reduces the amount of retail power that is consumed from the utility and thereby reduces the utility bill.

In a simple example, if a farm uses a total of 100,000 kWh of power in a month, but produces 80,000 kWh of solar electricity that month, then it is only consuming 20,000 kWh of utility power on a net basis, and its utility bill will decline accordingly.¹⁴¹ The key question is “What is a decline of 80,000 kWh in utility consumption worth?” In some parts of the United States, retail electricity can cost \$0.08/kWh (or less) and, in other regions, it can cost \$0.17/kWh or more.¹⁴² At the low end of that range, the solar power output is worth \$6,400/month. At the high end, it is worth \$13,600/month. For a State-by-State graph of average retail power prices, see chapter 3.

Wholesale power is purchased for re-sale by electric utilities or competitive generation suppliers and is typically associated with utility-scale PV systems. The monthly pattern of prices in six regional wholesale markets for 2018–2019 is shown in *exhibit 4-14*.¹⁴³ The location of the six markets is displayed on the map at the top of the price chart.

In *exhibit 4-14*, average monthly wholesale prices typically ranged from \$20 per megawatt-hour (MWh) to \$60/MWh (\$0.02/kWh to \$0.06/kWh), with the highest prices occurring during the summer months in the Electric Reliability Council of Texas (ERCOT) market in Texas. On an annual basis, average on-peak, wholesale prices often ranged in regional U.S. markets from approximately \$30/MWh to \$50/MWh (\$0.03/kWh to \$0.05/kWh) in 2017–2019, with the lowest prices occurring in the Northwest and the highest occurring in New England (EIA, 2020f).

¹³⁷ The specific inputs to LCOE calculations for PV typically include capital cost (\$/kW), fixed O&M cost (\$/kW-year), capacity factor (%), capital charge rate (%), and asset life (years). For other generation technologies that burn fuels, LCOE inputs also typically include fuel cost (\$/MMBtu), non-fuel variable O&M cost (\$/kWh), and heat rate for converting fuel to electricity (MMBtu/kWh). LCOE sometimes excludes incentives and taxes. A system's “capacity factor” is defined as its annual electricity output divided by the product of maximum rated capacity and the number of hours in a year.

¹³⁸ Lazard labels commercial-scale as “C&I” (abbreviation for “commercial and industrial”). It uses 5 kW as the prototype residential PV system size and 1,000 kW as the prototype C&I size (Lazard, 2019, p. 16).

¹³⁹ EIA produces LCOE analysis as well, but a recent LCOE publication did not include entity-scale PV and, therefore, does not have data reprinted in this chapter (EIA, 2020d, p. 2). However, EIA does produce utility-scale LCOE estimates for PV that are generally consistent with Lazard's LCOE estimates for that scale.

¹⁴⁰ In addition to energy payments, utility-scale PV systems may be eligible for capacity or ancillary service revenues for their physical output. For more information on these revenue streams, see FERC, 2020. Any PV system may also sell its renewable energy certificates, which are discussed in the next sub-section on financial incentive policies.

¹⁴¹ There are complexities in certain utility markets (pertaining to the hourly and sub-hourly patterns of electricity consumption and solar production, as well as utility rules for netting and compensating the difference [e.g., “net metering”]) that can complicate this simple example and that are discussed in the next sub-section of this chapter. The presence of peak demand, time-of-use energy, and fixed monthly utility charges also will complicate the example. However, in most locations, the directional basics of this example hold true.

¹⁴² Average annual retail power prices range from \$0.08/kWh in States such as Texas and Louisiana to \$0.15/kWh in New York, \$0.17/kWh in California, and \$0.29/kWh in Hawaii (EIA, 2019b).

¹⁴³ Price data in this exhibit are in dollars per megawatt-hour (\$/MWh). 1 MWh = 1,000 kWh. Therefore, a price of \$60/MWh is equal to \$0.06/kWh.

EXHIBIT 4-14: Regional Wholesale Electricity Prices in 2018–2019 (\$/MWh)

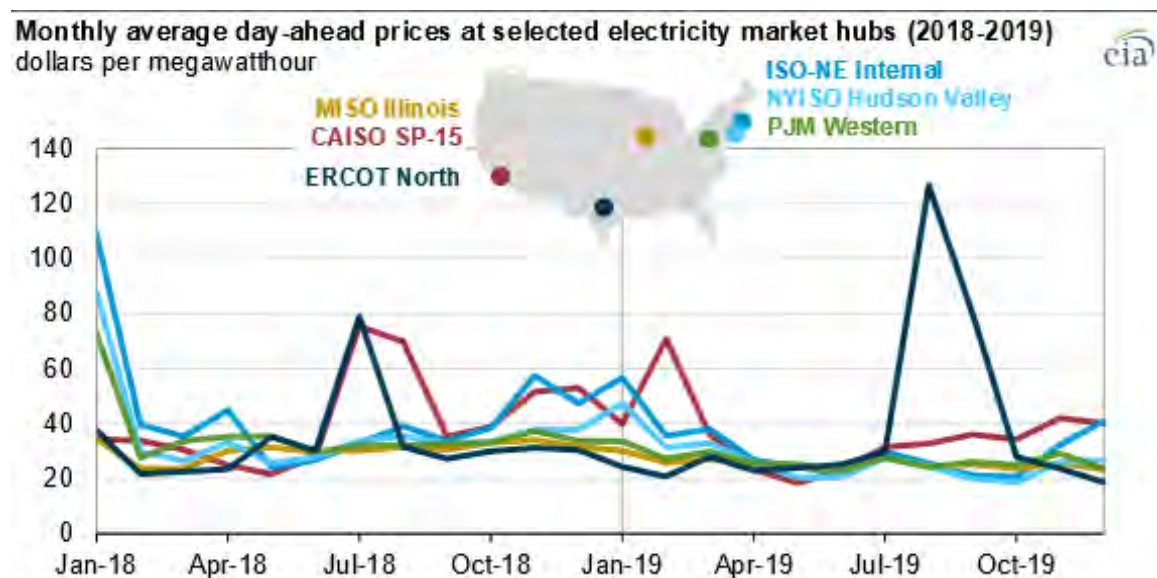

Source: EIA, 2020e.

Financial Incentive Policies

A mix of Federal and State financial incentives support adoption of PV technologies, with State policies having a substantial effect on the regional pattern of PV adoption.

Federal Incentive Policies

The Federal incentives are uniformly available across the country and consist of tax credits and depreciation allowances available to all tax-paying PV system owners, as well as Federal agency programs that tend to be more narrowly tailored, but do not operate through the tax code.

The most substantial Federal incentive is the investment tax credit (ITC). The ITC provides a tax benefit to offset 26 percent of the capital cost of PV projects in 2020. The ITC declines to 22 percent in 2021, then to 10 percent for business-owned systems and to 0 percent for resident-owned systems in 2022 and thereafter.¹⁴⁴

PV systems also can receive tax depreciation benefits under the Modified Accelerated Cost-Recovery System (NCCETC, 2018a). Both the ITC and accelerated depreciation can be received by entity-scale and utility-scale PV systems, but the system owner must be a tax-paying entity with sufficient tax liability to capture the benefits.

At the Federal agency level, there also are grants and loan guarantees specific to rural America that are administered by the U.S. Department of Agriculture (USDA), which cover PV and many other renewable technologies (USDA, 2020). For more information on USDA programs supporting renewable energy, see the section on financial incentives in chapter 3. The U.S. Department of Energy's (DOE's) Solar Energy Technologies Office (SETO) also announced a \$6.5 million funding opportunity in 2020, which seeks to build upon ongoing SETO projects to "enable farmers, ranchers, and other agricultural

¹⁴⁴ There is Internal Revenue Service guidance regarding how a PV system installed subsequent to a certain year can qualify for the higher ITC from a prior year if certain milestone activities occur in the development of the project. For an overview of that issue, see SEIA, 2018. A household can indirectly access the higher business ITC post-2021 if the PV system on its home is owned by a business that sells the power to the household (e.g., through a power purchase agreement).

enterprises to gain value from solar technologies while maintaining the availability of land for agricultural purposes" (DOE, 2020).

State Incentive Policies

While some States (e.g., Wyoming) have no significant PV incentives beyond net metering, others offer full (e.g., Arizona, Oregon) or partial exemptions from property and/or sales taxes for PV systems, production-based incentives such as markets for solar renewable energy certificates (e.g., Maryland), capital cost rebates, discounted loans, or other mechanisms (NCCETC, 2020a). State incentives largely explain why States such as Massachusetts and New Jersey have relatively high levels of PV deployment despite having relatively limited solar resources.

State financial incentives include Renewable Portfolio Standards (RPS) that mandate or target certain levels of renewables in a State—special solar “carve-outs” in States which require a portion of the RPS be met by solar—and broader Clean Energy Standards (CES). The variety of RPS and CES policies in the country, which can require renewable sources eventually comprise up to 100 percent of grid electricity, is displayed in chapter 5. States often have general renewable energy certificates (RECs), solar renewable energy certificates (SRECs), or similar accounting mechanisms to track RPS or CES progress. Sales of RECs or SRECs become a potential revenue stream for the PV system owner.¹⁴⁵

Another important type of State policy, applicable to entity-scale PV systems, is financial compensation for “net metering.” This type of policy determines payments and other rules for excess PV electricity production (beyond the power that a home, farm, or other business consumes on-site) sent back to the utility.^{146,147} Exhibit 4-15 shows the variability of net metering compensation policies as of 2016.

In addition to the financial incentives described above, there are State-, local-, and utility-level enabling policies that can facilitate wider adoption of PV systems. Such policies allow for faster and/or lower cost interconnection of PV systems with the distribution or transmission grids and straightforward permitting and zoning approvals.

Examples of State financial and enabling policies, beyond RPS and CES, that encourage PV development are listed in exhibit 4-16.¹⁴⁸

¹⁴⁵ PV systems produce two types of outputs: (1) physical energy (which is physically the same as energy from non-renewable sources), and (2) environmental attributes that are accounting mechanisms to distinguish and track the renewable (environmental and social) benefits of the output. Environmental attributes, of which RECs are the most common type for electricity generation projects in the United States, can be traded in financial markets. If the PV system owner sells the RECs, SRECs, or other environmental attributes to improve financial returns, then the owner cannot claim to be buying green power (EPA, 2019).

¹⁴⁶ To understand the net metering concept, it can be helpful to visualize an electricity meter spinning backwards when solar power is being exported to the utility. Depending on the utility, compensation for excess production can vary from zero to the full retail electricity rate. There also are “virtual net metering” arrangements in some cases that allow customers with multiple electricity meters with a utility to transfer excess solar production between the meters for billing purposes. For more information on standard and virtual net metering, see DOE, 2014.

¹⁴⁷ While more generous net metering policies support PV deployment, there are important questions raised about the proper limits of net metering policies and if and how those policies should be modified as PV deployment grows. As a result, net metering policies are often adjusted, or considered for adjustment.

¹⁴⁸ The Database of State Incentives for Renewables & Efficiency® (www.dsireusa.org) is a website where financial incentives and enabling policies can be reviewed for all States and at the Federal level.

EXHIBIT 4-15: Compensation Policies for Excess Generation From On-Site PV Systems by State

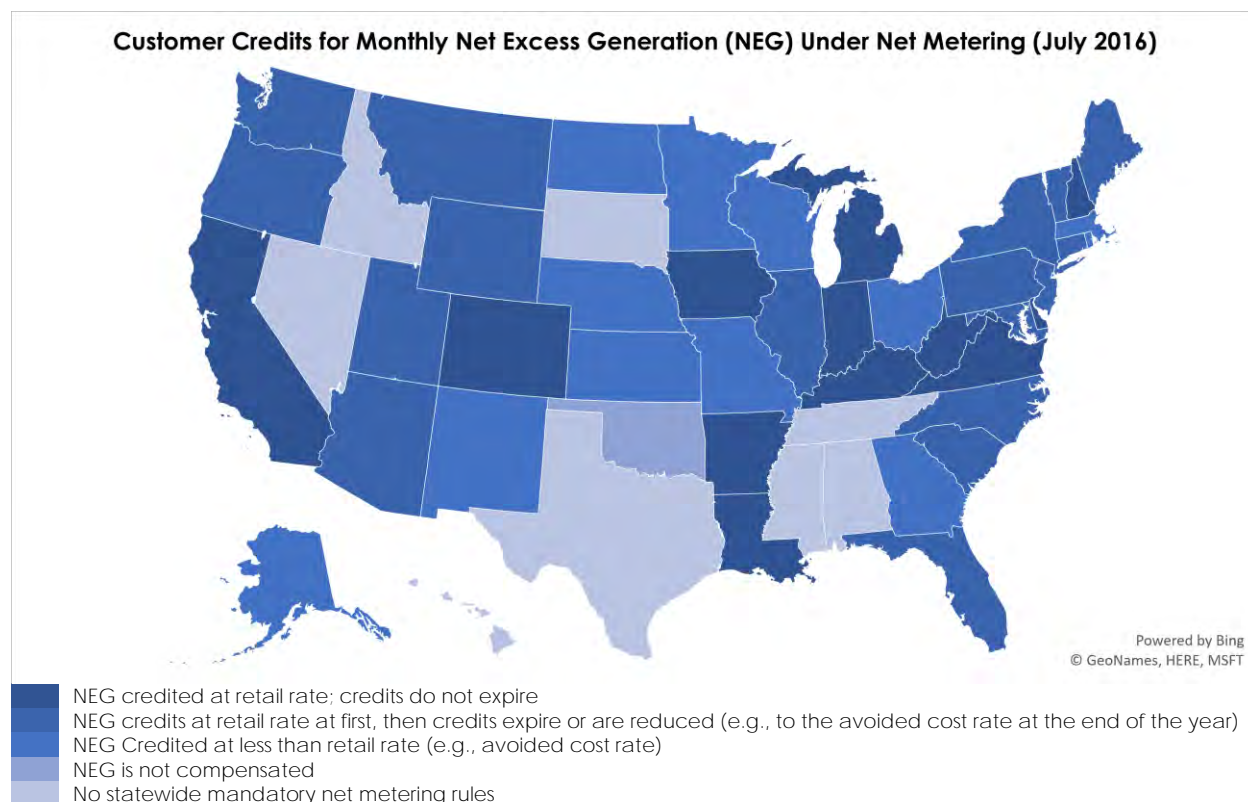

Note: The map shows NEG credits under statewide policies for investor-owned utilities (IOUs); other utilities may offer different NEG credit amounts. IOUs in HI, NV, MS, and GA have other policies for compensating self-generators. Some IOUs in TX and ID offer net metering, but there is no statewide policy. IOUs in WI differ in their treatment of NEG.

Source: ICF, based on NCCETC, 2016.

EXHIBIT 4-16: Examples of State-Level Financial and Enabling Policies for PV Systems

State	Incentive Name	Incentive Description
Arizona	Sales Tax Exemption	"A sales tax exemption for the retail sale of solar energy devices and for the installation of solar energy devices by contractors" (NCCETC, 2019a).
New York	NY-Sun Program	Rebates and financing (loans) for residential and commercial PV systems, as well as support for community solar projects (NYSERDA, 2020).
Oregon	Property Tax Exemption	"Any change in real market value to property due to the installation of a qualifying renewable energy system is exempt from assessment of the property's value for property tax purposes." Residential and commercial PV are included as qualifying systems (NCCETC, 2019b).
South Carolina	Personal Tax Credit	"Taxpayers may claim a credit of 25 percent of the costs of purchasing and installing a solar energy system or small hydropower system for ... the generation of electricity in a building owned by the taxpayer" (NCCETC, 2018b).
Vermont	Expedited Permitting Process for Small-Scale Systems	"An expedited permitting process [is in place] for solar photovoltaic systems that are 15 kW _{AC} or less and ... for net-metered solar PV systems greater than 15 kW that are mounted on a roof" (NCCETC, 2017a).
Wisconsin	FOCUS ON ENERGY®	Rebate for residential and commercial PV systems. There is a larger incentive available for rural households (in certain ZIP codes) (Focus On Energy, 2020).

Source: NCCETC, 2020a.

Aggregate Regional Effects

The aggregate result of the four drivers described above (solar resource, capital and O&M costs, wholesale and retail power prices, and financial incentive policies) is reflected in the PV deployment patterns in *exhibit 4-17*. The darker the color in a State, the higher the level of adoption (MW_{AC} of capacity installed).

EXHIBIT 4-17: Solar PV Generation Capacity by State (MW_{AC})

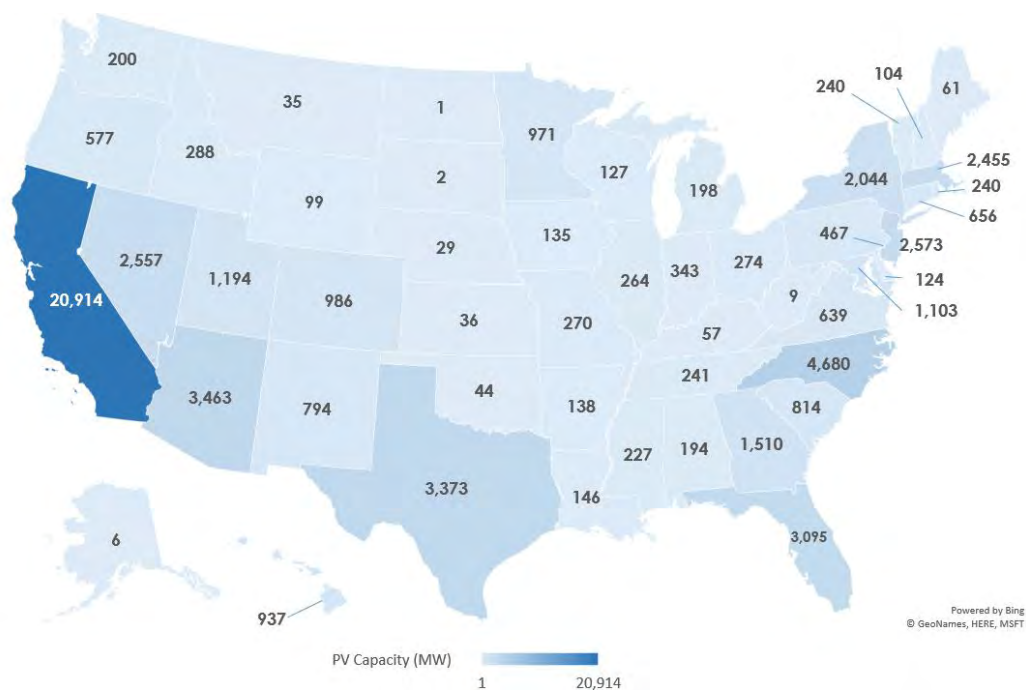

Source: Based on EIA, 2020a, table 6.2.B, with small aggregate differences versus national data in table 6.1.A.¹⁴⁹

California has deployed the most PV capacity of any State by a substantial margin, as seen in *exhibit 4-17*. Specifically, on farms, California also has the greatest amount of PV deployment. According to a 2013 USDA study, California had 25 percent of PV projects on farms by project count and 64 percent by PV capacity (USDA, 2013, p. 9). In that study, Texas, Hawaii, Colorado, and Oregon were the other States in the top 5 in number of farm-based, small-scale PV projects (USDA, 2013, p. 9).

Due to the drivers described above and the flexibility of PV technologies to be installed in almost any location, in on-grid or off-grid configurations, and in any size, PV systems have become the most common renewable technology deployed by farms (USDA, 2019, p. 60). The most recent *Census of Agriculture* notes that the number of farms with PV systems increased from 36,331 in 2012 to 90,142 in 2017, an increase of 148 percent (USDA, 2019, p. 60). Included in those totals are both PV systems and “solar thermal” (e.g., solar hot water) systems (USDA, 2019, p. B-21). While agricultural use of PV systems prior to 2000 was primarily in off-grid applications, since 2000 it has been in on-grid applications (the same is true for the broader economy) (USDA, 2013; USDA, 2011).

ADOPTION IMPACTS OF PV

Deployment of PV can bring the following six potential economic, environmental, and land use impacts to households, farms, and other businesses; PV system developers; and rural communities:

¹⁴⁹ Data on small-scale PV for Alabama and Georgia were not reported in the EIA table, so utility-scale PV data for those states were used for the purposes of this exhibit.

1. Land lease payments
2. Reduced greenhouse gas (GHG) emissions
3. Potential negative environmental and land use impacts
4. Employment
5. Electricity cost savings and budget certainty
6. Improved energy security

Land Lease Payments

For utility-scale systems, land lease payments are provided to owners of the land on which PV systems are located (unless the land is owned by the same party as the PV system). These lease payments can be significantly higher per megawatt of capacity than for wind energy generation systems, likely because PV systems restrict land uses to a greater degree than wind systems. For PV systems, annual lease rates can range from \$500 to \$1,000 per acre (NCCETC, 2017b, p. 4), which is roughly \$3,800 to \$13,000/MW_{AC} of PV capacity.¹⁵⁰ In comparison, annual land leases for wind energy systems are often \$3,000 to \$4,000/MW_{AC} (Windustry, 2020).

Reduced GHG Emissions

Almost all PV systems, as well as almost all wind energy systems, reduce GHG emissions. The only instances where they would not reduce GHG emissions are when the electricity they generate displaces electricity generated by nuclear or 100 percent renewable power systems (e.g., a market supplied entirely by hydropower).

The GHG emission reductions expected from a prototypical, new, utility-scale 10-MW_{AC} PV system located in three States—Kentucky, Florida, and Washington—are displayed in *exhibit 4-18*.^{151,152} The emission reductions in these States differ because the carbon intensity of the States' electricity grids is very different.

Kentucky has a coal-intensive generation mix, which is why emission reductions from a PV system in that State, other factors being equal, are much higher than in the other example States. On the other extreme, most of Washington State's electricity generation is from zero carbon emissions hydropower, with large portions of the State's generation also from other renewable sources and nuclear power. This means that introduction of a new PV system in Washington State will have a lower effect on grid emissions than in most other States.¹⁵³ In this exhibit, GHG reductions are displayed in metric tons of carbon dioxide equivalent (CO₂e)¹⁵⁴ removed from the electric grid, as well as two equivalent GHG reduction metrics.

¹⁵⁰ This conversion of per acre payments to per megawatt payments is based on total land area requirements for PV systems in NREL, 2013, p. 10.

¹⁵¹ The GHG emission reduction calculations underlying this exhibit are as follows: 10 MW_{AC} PV system capacity x assumed 25 percent capacity factor x 8,760 hours in a non-leap year = 21,900 MWh of electricity output from the PV system in a year. The PV capacity factor is assumed to be 25 percent per the national average for new utility-scale systems (LBNL, 2019b, p. 27). State-level emission factors of CO₂e from the U.S. Environmental Protection Agency (EPA, 2020b, p. 4) are converted from pounds/MWh to metric tons/MWh at a ratio of 2,204.623 pounds per metric ton to yield emission factors of 0.8327, 0.4299, and 0.0907 metric tons of CO₂e/MWh for Kentucky, Florida, and Washington State, respectively. These State-level emission factors are then multiplied by the annual electricity output of 21,900 MWh to obtain the emission reduction from 10-MW_{AC} PV systems in each State.

¹⁵² EPA's Greenhouse Gas Equivalencies Calculator was used to convert annual GHG reductions from the PV systems into equivalent GHG savings from removing passenger cars from the road for a year and removing homes' energy use for a year (EPA, 2020c).

¹⁵³ The strength of the solar resource also will affect GHG emission reductions, as it will differ from State-to-State and differ from individual site-to-site within a State. For this example, a constant PV capacity factor was applied so that the differences in carbon content of the States' electricity generation mix are clearly shown.

¹⁵⁴ In EPA's eGRID database, CO₂e is a summary measure that expresses the combined impact of three greenhouse gases (carbon dioxide [CO₂], methane [CH₄], and nitrous oxide [N₂O]) as an equivalent CO₂ impact. For more information on CO₂e calculations, see EPA, 2012.

EXHIBIT 4-18: Estimated Annual GHG Reductions and Equivalencies from 10-MW_{AC} Utility-Scale PV System in Selected States

State	Annual GHG Emission Reductions (metric tons of CO ₂ e)	Equivalent Reduction in Number of Passenger Vehicles	Equivalent Reduction in Number of Homes Using Energy
Kentucky	18,236	3,940	2,104
Florida	9,415	2,034	1,086
Washington	1,986	429	229

Sources: EPA, 2020b, p. 4; EPA, 2020c; LBNL, 2019b, p. 27.

For PV systems of different sizes, GHG reductions would be proportionately smaller or larger depending on system capacity and the capacity factor.¹⁵⁵

Potential Negative Environmental and Land Use Impacts

Though PV systems reduce GHG and other air emissions compared to conventional generation technologies and use small amounts of water during operations (NREL, 2011, p. 12), they can have negative effects on the environment due to:

- Hazardous materials used in solar panel manufacturing (EIA, 2019c)¹⁵⁶
- Additional infrastructure (e.g., power lines) and battery storage technologies used to integrate PV power onto distribution and transmission grids¹⁵⁷
- Disruptions of habitats for native plants and animals during system construction (EIA, 2019c)
- Changes in existing agricultural and other land use patterns in rural communities. Depending on local and regional circumstances, these changes may not be considered desirable by many.

Because PV systems cover large amounts of land,¹⁵⁸ they may alter agricultural patterns if they are heavily deployed in a region. For that reason, there is growing interest in use of pollinators and co-location of agricultural activities with PV systems, as described further in the Land Use Requirements section earlier in this chapter.

Employment

As shown in *exhibit 4-19*, the solar industry is now a major employer in the United States. *Exhibit 4-19* covers entity-scale and the larger utility-scale systems combined and indicates that more than 50 percent of solar industry jobs are in construction. Local construction jobs for PV installation (e.g., mounting solar panels, deploying the inverter and all other equipment, completing all associated electrical work) are particularly beneficial for rural economies. Of all solar jobs, 60 percent are in the entity-scale portions of the solar industry, as shown in *exhibit 4-20*.

¹⁵⁵ For example, a 100-kW_{AC} (0.1-MW_{AC}) commercial-scale PV system would have annual GHG reductions 1/100th as large as in *exhibit 4-18* if it had the same capacity factor as the 10,000-kW_{AC} (10-MW_{AC}) utility-scale system used in that exhibit. If the capacity factor (in AC) of the 100-kW_{AC} commercial-scale system was 20 percent instead of 25 percent, its annual GHG reductions would be 1/125th as large as for the 10,000-kW_{AC} system with a 25 percent capacity factor in the exhibit.

¹⁵⁶ The materials and chemicals used in manufacturing differ between the two main PV panel types: crystalline-silicon and thin-film. For a review of the hazards of these panel types and actions taken to protect public health from their effects, see NCCETC, 2017c.

¹⁵⁷ "Potential negative impacts of electricity storage will depend on the type and efficiency of storage technology. For example, batteries use raw materials such as lithium and lead, and they can present environmental hazards if they are not disposed of or recycled properly" (EPA, 2018).

¹⁵⁸ Utility-scale PV systems have direct land area requirements of 5.5 to 9.4 acres per MW_{AC} of generating capacity (NREL, 2013, p. 10).

EXHIBIT 4-19: Solar Employment by Sector in the United States

Sector Within Solar Industry	2019 Employment	Sector Share of Employment
Construction	126,979	51.2%
Professional Services	37,479	15.1%
Manufacturing	34,243	13.8%
Wholesale Trade	23,913	9.6%
Utilities	3,682	1.5%
Other Services	21,738	8.8%
TOTAL	248,034	100.0%

Source: NASEO, 2020, p. 41.

EXHIBIT 4-20: Solar Employees by System Type in the United States

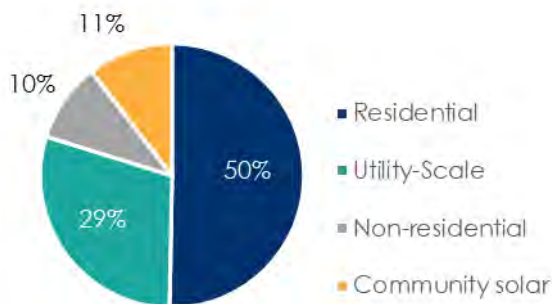

Source: ICF, based on NASEO, 2020, p. 57.

Electricity Cost Savings and Budget Certainty

Electricity cost reductions¹⁵⁹ to households or businesses installing an entity-scale PV system differ based on the ownership model in use. For third-party owned systems, cost reductions occur when the power purchase agreement (PPA) or lease payments are less than the reductions in utility bill costs. For self-owned systems, cost reductions occur when utility bill savings plus any environmental attributes that are sold exceed the amortized capital cost of the PV system plus O&M costs and any loan payments associated with the system.

Households and businesses that purchase electricity from the grid typically do not know what their long-term electricity prices (\$/kWh) will be. Grid prices fluctuate each year and are affected by fuel costs, general price inflation, and other factors. Installing a PV system provides electricity budget certainty, either by offering fixed PPA prices or lease payments (for third-party owned systems) or known investment costs that can be amortized over the PV asset life (for self-owned systems).

Lower wholesale electricity prices can result from utility-scale PV systems when the cost of PV electricity production (in isolation or as part of a supply mix) is less than the cost of other generation sources. Lower wholesale prices lead to lower retail power prices for households and businesses. An example of solar-driven cost reductions is that Georgia recently approved adding 2,210 MW of renewable generation (primarily PV) to Georgia Power Company's supply mix for cost-effectiveness reasons (Georgia PSC, 2019).

Improved Energy Security

Enhanced energy security is not a direct benefit of most entity-scale PV systems because they are typically configured so that the inverter shuts down within milliseconds of a grid outage. This is to protect utility line workers, firefighters, and others who may be exposed to power lines and other grid components during an outage and to protect PV equipment. However, with added cost and complexity, stand-alone, on-grid PV systems can be configured to include an energy storage system (e.g., a lithium-ion or lead-acid battery system) to offer emergency power during grid outages. Although such systems are higher in cost, they do provide entities with increased energy security and independence. Off-grid PV systems, such as farm systems for water pumping, offer energy security because they have no interconnection with, or dependence upon, utility grid power.

¹⁵⁹ The potential effects of PV investments on for-profit agricultural or forestry business income taxes are not included in these simple formulas.

DOMINANT OWNERSHIP/FINANCING MODEL FOR PV

For PV systems, there are two broad ownership models:

1. Self-ownership with or without loans by the residential or commercial electricity end-user (for entity-scale systems) or by the utility (for utility-scale systems).
2. Third-party ownership with a private company other than the system host owning the PV system.
 - a. For entity-scale systems, the owner (power producer) sells solar output at an established price (\$/kWh) to the host (residential or commercial electricity end-user) on a monthly basis via a PPA, or the system host makes fixed lease payments to the owner.
 - b. For utility-scale systems, the solar output is typically sold by the power producer to a power reseller (a utility or a competitive generation supplier), directly to a large electricity end-use customer (such as a data center), or via community solar sales to end-use customers of any size.^{160,161}

Both ownership models are widely used, although with distinctions by region and type of system host. As shown in *exhibit 4-21*, PPAs are not available everywhere in the United States. Where they are available, they typically offer a turnkey solution whereby the third-party owner designs, engineers, permits, builds, finances, owns, operates, and maintains the system for a term of 10 to 30 years. Lease structures tend to be similar to PPAs, although substituting a fixed-monthly lease payment for output-based (kWh) payments.

In the case of both PPAs and leases, intra-term buyout provisions are common (although not required). These provisions allow the host (e.g., rural household or farm owner) to purchase the PV system at specified costs each year during the contract period.

A potentially important benefit of PPAs and leases is that they allow for the efficient use of Federal tax-based incentives (ITC and accelerated depreciation) to effectively lower the net cost of the PV system. These Federal incentives, which can lower net capital costs by 40 percent or more on a combined basis, are only available to PV owners with tax liability. For nonprofit and public agency system hosts, third-party PV ownership with a PPA or lease is the only way that the hosts can benefit from the Federal incentives. Third-party ownership also may be attractive to households or private sector agricultural or forestry businesses if they do not have sufficient tax liability or internal accounting knowledge to monetize tax benefits.

However, even where solar PPAs and leases are available, self-ownership may be a better choice for households and businesses if they wish to exert more control over the technical specifications and operation of the PV system, wish to eliminate third-party profit on PPA or lease payments and capture tax benefits directly, do not want to have a third-party own property on their sites, or do not have adequate creditworthiness to obtain an attractive PPA or lease price.

¹⁶⁰ "Community solar" is a subset of the utility-scale PV market. Such projects are typically at the small end of that market, with project capacity of 0.5 to 5 MW, and are distinguished by utility-defined rules allowing residential and commercial customers to buy (or subscribe to) small amounts of output from the projects. For more information on community solar, see SEIA, 2020b.

¹⁶¹ There also are cases of PV systems owned by independent power producers not having long-term, fixed-price contracts and selling power into the local spot electricity market.

EXHIBIT 4-21: Legal Status of Third-Party PV PPAs by State

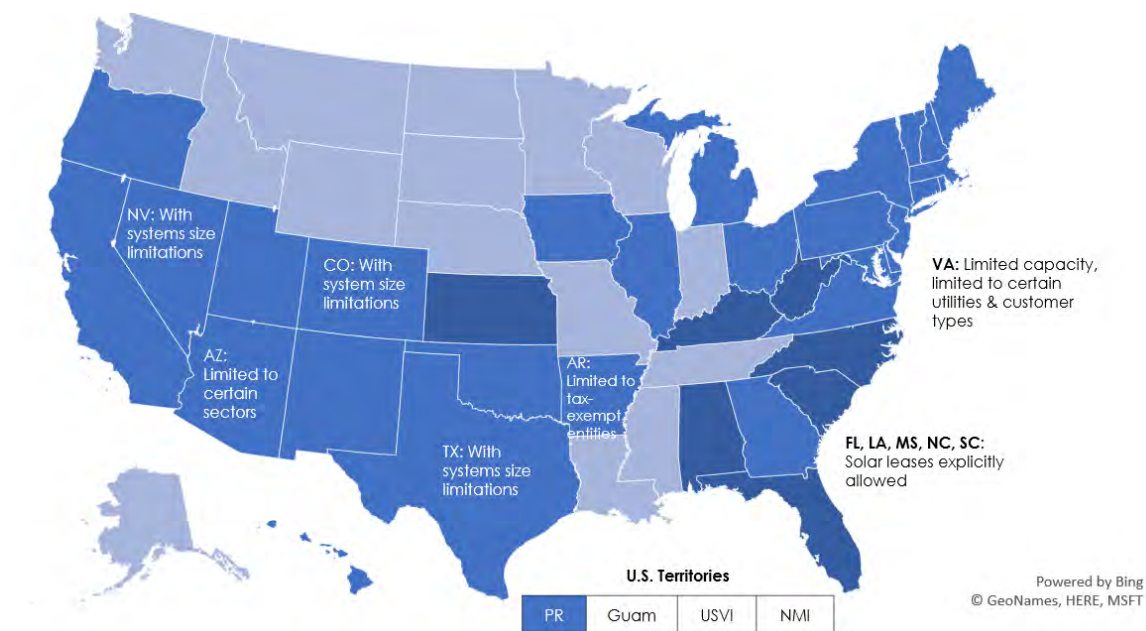

- Apparently disallowed by state or otherwise restricted by legal barriers
- Authorized by state or otherwise currently in use, at least in certain jurisdictions
- Status unclear or unknown

Note: At least 28 states + Washington DC and Puerto Rico authorize or allow 3rd Party Power Purchase Agreements for Solar PV.

Source: ICF, based on NCCETC, 2019c.

Overall, PPAs by third parties (neither the system host nor the utility) were the most common financing mechanism for entity-scale PV systems in several States in the early 2010s. However, due to greater availability of direct solar loans for homeowners and businesses, as well as declining system capital costs that improve investment returns, the relative popularity of PPAs has declined nationwide for entity-scale systems, as shown in exhibit 4-22 (LBNL, 2019a, pp. 16–17).

EXHIBIT 4-22: Changing Market Share of Third-Party Ownership (TPO) of Entity-Scale PV Systems

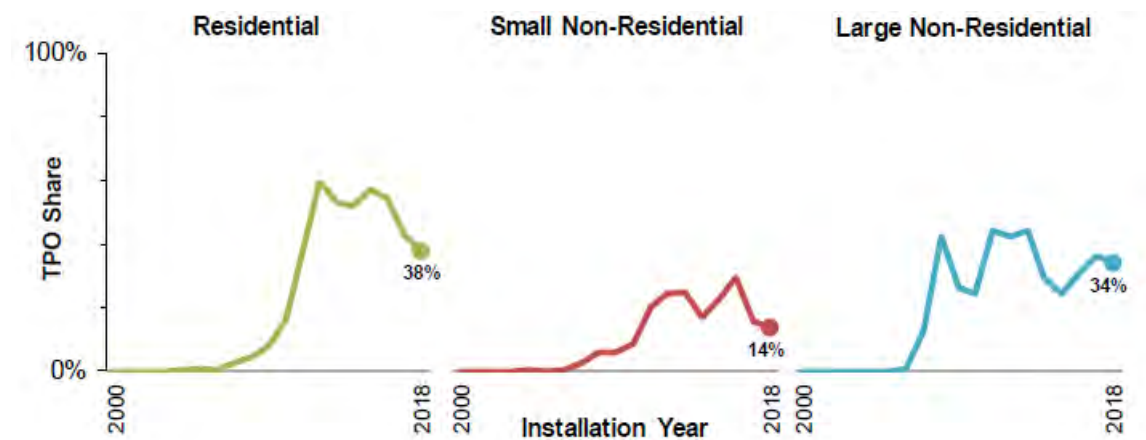

Source: LBNL, 2019a, p. 17.

BATTERY ENERGY STORAGE: SUPPORTING TECHNOLOGY FOR SOLAR PHOTOVOLTAIC AND OTHER RENEWABLE ELECTRICITY GENERATION SYSTEMS

Battery energy storage systems (BESS) are becoming increasingly common, both as stand-alone systems (without being directly linked to an electricity generator) and integrated with PV or wind technologies. Although battery storage is not a renewable energy technology, it is an important enabling technology for renewable energy development.

The main technical rationale for pairing battery storage with PV (and wind) systems is that batteries allow the timing of electricity production to be separated from the timing of electricity consumption (for entity-scale systems) and electricity sales (for utility-scale systems). Storing and then dispatching electricity at chosen times can both increase the value of electricity generated by renewable energy systems and allow higher levels of deployment without negative transmission and distribution grid impacts. Adding BESS to solar or wind energy projects can thereby lead to more utility-scale land leases on agricultural lands and, under certain circumstances, better system economics for entity-scale PV systems at rural households and businesses.

While the benefits of PV + BESS have been known for years, what has changed recently is the cost-effectiveness of BESS. Overall system costs for the dominant battery storage chemistry—lithium-ion—declined by 74 percent between 2012 and 2018 (GTM Research, 2019).

Technology Description

There are many types of batteries, with different chemistries, that can be used for energy storage. The choice of battery type depends on cost factors, as well as how performance characteristics match intended uses and discharge speeds.¹⁶²

For most BESS, typical components are shown in *exhibit 4-23*. In that exhibit, the “storage device” is the DC battery itself and the associated racking and battery management system. The power conversion system includes an inverter to convert DC to AC power, inverter controls, and a container (PNNL, 2019, p. 3.1).

EXHIBIT 4-23: Basic Components of a Battery Energy Storage System

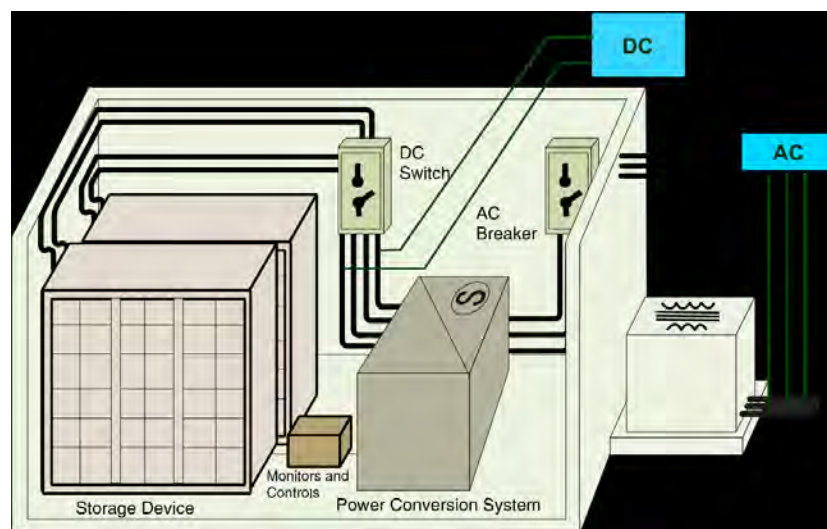

Source: Sandia, 2015, p. xxxiv.

¹⁶² To review the typical scale (in power), uses, and discharge speeds for several types of batteries and other non-battery forms of energy storage, see Sandia, 2015, p. 29 and ADB, 2018, p. 3.

Adoption Costs

BESS capital costs are comprised of both power-based costs and energy-based costs.¹⁶³ A BESS with more energy will be more expensive than a BESS with the same amount of power and less energy.

For a lithium-ion BESS with 1,000 kW of power and 4,000 kWh of energy, the total installed (pre-incentive) cost in 2018 was \$1,876,000 (PNNL, 2019, pp. 4-3 – 4-4). This cost represents unit costs of \$1,876/kW and \$469/kWh. Other battery types are typically more expensive than lithium-ion batteries for systems of that size, which is equivalent to small utility-scale or very large commercial-scale BESS (PNNL, 2019, p. 4-4). Due to economies of scale, per unit BESS costs tend to be higher for commercial and for residential systems that are much smaller than this example system (see, for example, EPRI, 2018).

These are BESS capital costs for stand-alone systems (without being paired with PV). When paired with PV, capital costs of large utility-scale, PV + BESS systems decline by 7 percent to 8 percent due to efficiencies in shared hardware, site preparation, land acquisition, interconnection, installation, and other activities (NREL, 2018c, p. iv). The Federal ITC can be applied to BESS capital costs if a BESS is paired with and substantially charged from a PV system (NREL, 2018d).¹⁶⁴

For BESS, both fixed and variable O&M costs are relevant. Fixed O&M costs average about \$10/kW of power capacity per year, while variable O&M costs are about \$0.0003/kWh of energy discharged (PNNL, 2019, p. 3.5).

Market Size

In 2018, U.S. deployments of BESS were 311 MW on a power basis and 777 MWh on an energy basis (WoodMac, 2019, pp. 3–4). These totals were, respectively, 44 percent and 80 percent higher than the battery power and energy deployed in 2017, and more than triple the levels in 2013 and 2014 (WoodMac, 2019, pp. 3–4). While the BESS market is growing rapidly, it is still much smaller than the PV or wind energy generation markets. For comparison, more than 8,000 MW_{AC} of new PV capacity was deployed in the United States in 2018 (NREL, 2019c, p. 2).

Among battery chemistries, lithium-ion has the greatest share of the U.S. and global energy storage markets. Cumulative global deployment is shown in *exhibit 4-24*.¹⁶⁵

EXHIBIT 4-24: Installed Global Battery Storage Power Capacity by Chemistry (Through 2018)

Battery Chemistry	Power Capacity Deployed (MW)
Lithium-ion	1,629
Sodium Sulfur	189
Lead Acid	75
Flow (various chemistries)	72
Sodium Metal Halide	19

Source: PNNL, 2019, p. 2.1.

SOLAR WATER AND AIR HEATING SYSTEMS

In addition to converting solar energy to electricity (e.g., through PV systems), there are technologies that use solar energy to heat water and air.¹⁶⁶ Because the solar water heating (SWH) market is larger

¹⁶³ BESS “power” represents the maximum instantaneous electricity output that a given BESS is rated to produce when starting from a fully charged state. “Energy” has an elapsed time dimension and represents the cumulative stored electricity output potential of the BESS. Power is expressed in kW or MW, while energy is expressed in kWh or MWh.

¹⁶⁴ BESS must be charged from solar electricity more than 75 percent of the time (with the balance being charged from conventional grid electricity) to qualify for any ITC on the BESS portion of the system (NREL, 2018d). There also are Federal accelerated depreciation benefits that can be claimed by PV + BESS systems that vary with how the BESS is charged by solar power.

¹⁶⁵ Beyond the battery types listed in this exhibit, there are other forms of energy storage such as flywheels, compressed air energy storage, and pumped hydropower storage. These other types of storage tend to have small global market shares, except for pumped hydropower, which had approximately 100 times as much cumulative global capacity as lithium-ion systems in 2018 (PNNL, 2019, p. 2.1).

¹⁶⁶ Solar water heating and solar air heating technologies are a subset of “solar thermal” technologies, which also include technologies such as solar air cooling and solar thermal electricity generation.

nationally and has greater data availability than the solar air heating market, it is emphasized in this section.¹⁶⁷

Technology Description: Solar Water Heating

SWH technologies often have greater energy conversion efficiency than PV systems because they do not need to transform energy into alternating current. SWH applications include domestic water heating, process water heating (e.g., equipment sterilization; heating water for fish hatcheries; milk pasteurization; building cleanup; environmental control for livestock, dairy, and food processing operations), and pool heating (USDA, 2011, pp. 17–19).

There are several configuration and component choices available for SWH systems.¹⁶⁸ Exhibit 4-25 shows the most common type of SWH system in the United States—an “active” system using an electric pump to circulate the heat transfer fluid (water or a chemical such as propylene glycol) (EIA, 2018a, p. 62).¹⁶⁹

EXHIBIT 4-25: How a Typical Active Solar Water Heating System Operates

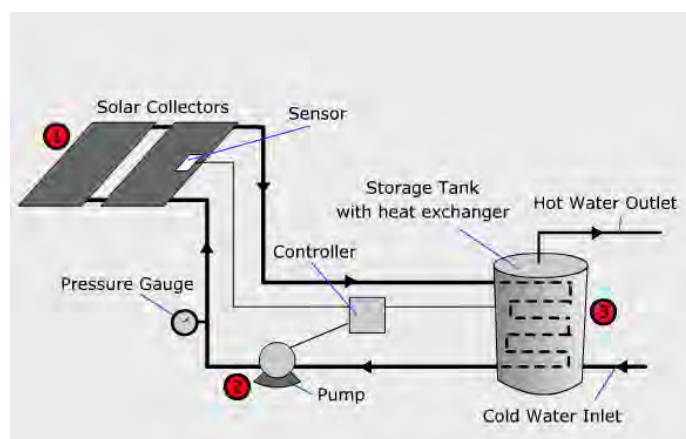

Source: Penn State, 2018.

SWH systems tend to be smaller than PV systems in the number of panels, and the panels (often called “collectors” for SWH systems) are visually distinct from PV panels. In exhibit 4-26, the image on the left is a flat panel collector system, while the image on the right is an evacuated tube collector.

EXHIBIT 4-26: Metal-and-Glass Collectors for Solar Water Heating Systems

Flat panel collector system



Evacuated tube collector



Sources: EPA, 2016 (left); SRCC, 2015, p. 17 (right).

¹⁶⁷ Both the solar water and air heating markets are smaller than the national PV market.

¹⁶⁸ Residential- and commercial-scale systems tend to have similar types of components, although commercial designs often have greater customization to integrate the SWH components with existing water heating systems in buildings. At both scales, SWH systems are typically sized to cover less than the full water heating requirements of the household or commercial buildings and are supplemented by conventionally fueled sub-systems.

¹⁶⁹ There are also “passive” SWH systems without pumps.

As lower cost and lower productivity alternatives to the metal-and-glass collectors displayed in *exhibit 4-26*, SWH systems can use plastic collectors, as shown in *exhibit 4-27*. *Exhibit 4-28* is an example of an SWH system on an agricultural building.

EXHIBIT 4-27: Plastic Collectors for Solar Water Heating Systems



Source: FEMP, 2012, p. 1.

EXHIBIT 4-28: Evacuated Tube Solar Water Heating System on a Barn in Massachusetts



Source: City of Leominster, 2020.

Adoption Costs: Solar Water Heating

Typical costs for installing and maintaining SWH systems are listed in *exhibit 4-29*.¹⁷⁰ These costs correspond to residential-scale systems. Larger commercial- or farm-scale systems have lower unit capital costs.¹⁷¹ In general, SWH systems in cold-weather climates tend to be larger (because more collector square footage is needed) and, therefore, more expensive than in warm-weather climates (EIA, 2018a, p. 62).

EXHIBIT 4-29: Summary of Solar Water Heating Capital and O&M Costs

	Unit Capital Cost in \$/square foot of collector (pre-incentive)	Typical Residential Project Size (square feet)	Total Residential Capital Cost: Midpoint Value (pre-incentive)	Annual Fixed O&M Cost
Conventional (flat plate or evacuated tube) Collector Systems	\$71 to \$253 (midpoint = \$162)	40	\$6,480	0.5% to 1.0% of capital cost
Plastic Collector Systems	\$44 to \$74 (midpoint = \$59)	32–48	\$2,360	0.5% to 1.0% of capital cost

Sources: NREL, 2016 (for unit capital and O&M costs); FEMP, 2012, p. 8 (for average system size).

¹⁷⁰ For comparison with data in *exhibit 4-29*, EIA estimates the 2020 capital costs of residential SWH systems (with 42 square feet of collectors) as \$7,100 (EIA, 2018a, p. 61). Hawaii Energy lists average residential SWH system capital costs as \$6,300 to \$7,200 pre-incentive in its State (Hawaii Energy, 2020).

¹⁷¹ For example, a commercial SWH system with 400 square feet of conventional collectors (10 times as large as a typical residential system) has unit capital costs (per square foot) that are 33 percent less than for residential systems (FEMP, 2012, p. 8).

SWH systems, for most uses other than swimming pool and hot tub heating, are eligible for the Federal ITC at the same levels as PV systems (NCCETC, 2020b). This incentive decreases the net capital costs of systems.

Market Size: Solar Water Heating

DOE's national modeling indicates that less than 1 percent of residential water heating systems were primarily served by SWH in 2017 and 2018 (EIA, 2018b). More than two-thirds of U.S. residential SWH systems are in Southern or Western States (EIA, 2018a, p. 62).

Technology Overview: Solar Air Heating

This technology is used primarily to pre-heat ventilation air, such as in a poultry building. Solar air heating systems typically have vertical walls¹⁷² of perforated plate or transpired solar collectors along the south side of the building exterior (for systems in the Northern Hemisphere) to increase solar energy production (Cui, et al., 2020, p. 129; USDA, 2011, p. 19). A transpired solar air heating collector wall is shown in *exhibit 4-30*.

The heated air is then circulated from the area behind the collector wall via fans and ducts to the ventilation system within the building (EPA, 2020a). The outside air can be heated by 27 degrees Celsius in many cases (Cui, et al., 2020, p. 129).

EXHIBIT 4-30: Solar Air Heating System Exterior on a Warehouse



Source: EPA, 2020a.

Solar air heating systems have the potential for attractive economic returns for agricultural businesses, with internal rates of return of greater than 10 percent (USDA, 2011, p. 19). The economics of these systems tend to be most favorable when an expensive heating fuel (e.g., propane in a remote area, fuel oil) is used for space heating within the building.

CHALLENGES TO EXTENDING ADOPTION

Unlike some renewable energy technologies available to farm and forestry organizations (such as biomass power generation systems), PV systems do not have significant challenges with regard to investment returns, outside financing availability, or resource supply. Because PV capital costs have declined so rapidly, and an industry for financing, installing, and maintaining PV systems now exists in many parts of the country, cumulative PV adoption has grown well over a hundred-fold in many States over the past 12 years.

The principal challenges to increasing deployment of PV systems (including expanding in States and communities that currently have low adoption rates) are:

- Overcoming net increases in PV investment costs that may arise over the next several years due to declines in the Federal ITC;
- Managing the potentially disruptive process of having more small PV systems backfeeding power into electric utility distribution grids, and utility-scale systems causing power intermittency challenges for transmission grids¹⁷³; and
- Mitigating land use impacts for ground-mounted systems.

The Federal ITC (a direct capital incentive) started declining in 2020, which will likely cause a near-term rush to deploy PV systems, but may lead to a drop-off in adoption thereafter. Interest rates may also

¹⁷² Solar air heating systems can also be mounted on roofs.

¹⁷³ For more information on the distinctions between distribution and transmission grids and the challenges of integrating intermittent renewable electricity generation, see chapter 5.

begin to increase after having been at historically low levels over the past 10 years. Because many PV investors borrow to cover more than half of the PV capital costs, higher interest rates may also reduce the investment prospects for PV, especially if not accompanied by rises in the cost of utility power that PV offsets.

PV is also encountering a new set of problems as a result of its popularity—high levels of PV penetration on individual utility circuits (line sections) and utility systems overall can make it more technically challenging and expensive to operate the grid. This, in turn, can lead to (1) higher utility interconnection costs for PV, (2) shifts to different rate structures for PV (e.g., higher fixed and/or peak demand charges), and (3) limitations on PV system size or production relative to on-site business or household electricity consumption. Similar issues also arise on transmission grids due to the growth of large, utility-scale PV systems. Because electricity consumption on any grid **“must be continuously balanced,”** variable power generation sources like solar and wind are less flexible in meeting consumption needs (EIA, 2020d, pp. 2–3). Combining battery systems with PV can ameliorate some of these issues by storing excess solar power and discharging it when the grid can more easily accommodate it.

In rural communities with growing PV penetration, there also can be concerns about PV system impacts on land use, agricultural output, and agricultural employment. If productive lands are frequently converted from agricultural to solar energy uses, the business profile of the community may change. While this conversion is unlikely to occur across entire States,¹⁷⁴ within individual counties or smaller areas, the effect can be significant. For this reason, there is growing interest in PV site development plans that promote agriculturally beneficial vegetation underneath and alongside PV arrays (NREL, 2019b).

¹⁷⁴ In North Carolina, a State with high PV penetration, approximately 15,000 acres of cropland were occupied by PV systems in early 2017 (NCCETC, 2017b, p. 5). This represents less than one-third of 1 percent of the State's cropland (NCCETC, 2017b, p. 5). As the State fulfills its renewable energy requirements, this figure may rise to 75,000 acres, or about 1.1 percent of cropland in the State (NCCETC, 2017b, p. 6).

REFERENCES

- ADB. 2018. *Handbook on Battery Energy Storage Systems*. Asian Development Bank. <https://www.adb.org/sites/default/files/publication/479891/handbook-battery-energy-storage-system.pdf> [accessed April 2020].
- City of Leominster. 2020. Solar. <https://www.leominster-ma.gov/gov/boardcomm/energy/solar.asp> [accessed April 2020].
- Cornell University. 2018. *The Agricultural, Economic and Environmental Potential of Co-locating Utility Scale Solar with Grazing Sheep*. David R. Atkinson Center for a Sustainable Future, Cornell University. https://cpb-us-e1.wpmucdn.com/blogs.cornell.edu/dist/f/6685/files/2015/09/Atkinson-Center-report-2018_Final-22l3c5n.pdf [accessed May 2020].
- Cui, et al. 2020. A Comprehensive Review on Renewable and Sustainable Heating Systems for Poultry Farming. *International Journal of Low-Carbon Technologies*, Volume 15, Issue 1. Cui, Yuanlong, Elmer Theo, Tugba Gurler, Yuehong Su, and Riffat Saffa. <https://academic.oup.com/ijct/article/15/1/121/5631833> [accessed April 2020].
- DOE. 2010. *2008 Solar Technologies Market Report*. U.S. Department of Energy. <https://www.nrel.gov/docs/fy10osti/46025.pdf> [accessed April 2020].
- DOE. 2014. *Net Metering*. U.S. Department of Energy. https://www.energy.gov/sites/prod/files/2014/05/f15/fupwg_may2014_net_metering.pdf [accessed April 2020].
- DOE. 2020. Funding Opportunity Announcement: Solar Energy Technologies Office, Fiscal Year 2020 Funding Program. U.S. Department of Energy. <https://www.energy.gov/eere/solar/funding-opportunity-announcement-solar-energy-technologies-office-fiscal-year-2020> [accessed April 2020].
- EIA. 2017. More Than Half of Utility-Scale Solar Photovoltaic Systems Track the Sun Through the Day. U.S. Energy Information Administration, DOE. <https://www.eia.gov/todayinenergy/detail.php?id=30912> [accessed April 2020].
- EIA. 2018a. *Technology Forecast Updates—Residential and Commercial Building Technologies: Reference Case*. U.S. Energy Information Administration, DOE. <https://www.eia.gov/analysis/studies/buildings/equipcosts/pdf/appendix-a.pdf> [accessed April 2020].
- EIA. 2018b. Annual Energy Outlook 2018, Table: Residential Sector Equipment Stock and Efficiency, and Distributed Generation: Reference Case. U.S. Energy Information Administration, DOE. <https://www.eia.gov/outlooks/aeo/data/browser/#/?id=30-AEO2018&cases=ref2018&sourcekey=0> [accessed April 2020].
- EIA. 2019a. Existing Net Summer Capacity of Other Renewable Sources by Producer Type, 2008 through 2018 (Megawatts). U.S. Energy Information Administration, DOE. https://www.eia.gov/electricity/annual/html/epa_04_02_b.html [accessed March 2020].
- EIA. 2019b. State Electricity Profiles (Release Date: December 31, 2019). U.S. Energy Information Administration, DOE. <https://www.eia.gov/electricity/state/> [accessed February 2020].
- EIA. 2019c. Solar Explained: Solar Energy and the Environment. U.S. Energy Information Administration, DOE. <https://www.eia.gov/energyexplained/solar/solar-energy-and-the-environment.php> [accessed August 2020].
- EIA. 2020a. Electric Power Monthly: Estimated Net Summer Solar Photovoltaic Capacity From Utility and Small Scale Facilities, Data for January 2020. U.S. Energy Information Administration, DOE. <https://www.eia.gov/electricity/monthly/> [accessed April 2020].
- EIA. 2020b. *Appendix C: Technical Notes: Electric Power Monthly, Data for January 2020*. U.S. Energy Information Administration, DOE. <https://www.eia.gov/electricity/monthly/pdf/technotes.pdf> [accessed March 2020].
- EIA. 2020c. *Short-Term Energy Outlook, April 2020*. U.S. Energy Information Administration, DOE. https://www.eia.gov/outlooks/steo/pdf/steo_full.pdf [accessed April 2020].
- EIA. 2020d. *Levelized Cost and Levelized Avoided Cost of New Generation Resources in the Annual Energy Outlook 2020*. U.S. Energy Information Administration, DOE. https://www.eia.gov/outlooks/aeo/pdf/electricity_generation.pdf [accessed April 2020].
- EIA. 2020e. Wholesale Electricity Prices Were Generally Lower in 2019, Except in Texas. U.S. Energy Information Administration, DOE. <https://www.eia.gov/todayinenergy/detail.php?id=42456> [accessed April 2020].
- EIA. 2020f. Wholesale Electricity and Natural Gas Market Data. U.S. Energy Information Administration, DOE. <https://www.eia.gov/electricity/wholesale/#history> [accessed March 2020].
- EPA. 2012. *How to Use eGRID for Carbon Footprinting Electricity Purchases in Greenhouse Gas Emission Inventories*. U.S. Environmental Protection Agency. <https://www3.epa.gov/ttnchie1/conference/ei20/session3/adiem.pdf> [accessed April 2020].

- EPA. 2016. Solar Heating and Cooling Technologies. U.S. Environmental Protection Agency. <https://www.epa.gov/rhc/solar-heating-and-cooling-technologies> [accessed March 2021].
- EPA. 2018. Electricity Storage. U.S. Environmental Protection Agency. <https://www.epa.gov/energy/electricity-storage> [accessed August 2020].
- EPA. 2019. Green Power Partnership, Making Environmental Claims. U.S. Environmental Protection Agency. <https://www.epa.gov/greenpower/making-environmental-claims> [accessed April 2020].
- EPA. 2020a. Solar Heating and Cooling Technologies. U.S. Environmental Protection Agency. <https://www.epa.gov/rhc/solar-heating-and-cooling-technologies> [accessed March 2020].
- EPA. 2020b. eGRID Summary Tables 2018. U.S. Environmental Protection Agency. https://www.epa.gov/sites/production/files/2020-01/documents/egrid2018_summary_tables.pdf [accessed March 2020].
- EPA. 2020c. Greenhouse Gas Equivalencies Calculator (last updated March 2020). U.S. Environmental Protection Agency. <https://www.epa.gov/energy/greenhouse-gas-equivalencies-calculator> [accessed March 2020].
- EPRI. 2018. *Energy Storage Technology and Cost Assessment: Executive Summary*. Electric Power Research Institute. <https://www.epri.com/#/pages/product/000000003002013958/?lang=en-US&lang=en-US&lang=en-US&lang=en-US> [accessed May 2020].
- FEMP. 2012. *Solar Water Heating With Low-Cost Plastic Systems*. Federal Energy Management Program, DOE. <https://www.15000inc.com/wp/wp-content/uploads/Solar-Water-Heating-Systems.pdf> [accessed April 2020].
- FERC. 2020. Electric Power Markets. Federal Energy Regulatory Commission. <https://www.ferc.gov/market-assessments/mkt-electric/overview.asp> [accessed April 2020].
- Focus On Energy. 2020. Renewable Energy Program. <https://focusonenergy.com/residential#undefined> [accessed May 2020].
- Georgia PSC. 2019. *Commission Adds 2,210 MW of Renewable Energy in Georgia Power 2019 Integrated Resources Plan*. Georgia Public Service Commission. https://psc.ga.gov/site/assets/files/4279/media_advisory_for_7-16-19_gpc_irp_for_web.pdf [accessed April 2020].
- GTM Research. 2016. 20 US States at Grid Parity for Residential Solar. <https://www.greentechmedia.com/articles/read/GTM-Research-20-US-States-at-Grid-Parity-for-Residential-Solar#gs.4oEVsY6> [accessed April 2020].
- GTM Research. 2019. Levelized Cost of Energy for Lithium-Ion Batteries Is Plummeting. <https://www.greentechmedia.com/articles/read/report-levelized-cost-of-energy-for-lithium-ion-batteries-bnef> [accessed April 2020].
- Hawaii Energy. 2020. The Cost of a Solar Water Heating System. <https://hawaiienergy.com/for-homes/solar-water-heating/the-cost-of-a-solar-water-heating-system> [accessed April 2020].
- Idaho. 2021. Solar, Power Generation. State of Idaho, Governor's Office of Energy and Mineral Resources, <https://oemr.idaho.gov/sources/re/solar/> [accessed February 2021].
- Lazard. 2019. *Lazard's Levelized Cost of Energy Analysis—Version 13.0*. <https://www.lazard.com/media/451086/lazards-levelized-cost-of-energy-version-130-vf.pdf> [accessed April 2020].
- LBNL. 2019a. *Tracking the Sun: Pricing and Design Trends for Distributed Photovoltaic Systems in the United States, 2019 Edition*. Ernest Orlando Lawrence Berkeley National Laboratory. https://emp.lbl.gov/sites/default/files/tracking_the_sun_2019_report.pdf [accessed March 2020].
- LBNL. 2019b. *Utility Scale Solar: Empirical Trends in Project Technology, Cost, Performance, and PPA Pricing in the United States, 2019 Edition*. Ernest Orlando Lawrence Berkeley National Laboratory. https://emp.lbl.gov/sites/default/files/lbnl_utility_scale_solar_2019_edition_final.pdf [accessed March 2020].
- Michiana. 2020. *Technical Guide: Establishment and Maintenance of Pollinator-Friendly Solar Projects*. Michiana Area Council of Governments. http://macog.com/docs/sustainability/solar_energy/Pollinator-Friendly-Solar-Guide-Version-1-1.17.2020.pdf [accessed March 2020].
- MNDOC. 2020. Made in Minnesota Solar Incentive Program. Minnesota Department of Commerce. <https://mn.gov/commerce/industries/energy/solar/mim/> [accessed April 2020].
- NASEO. 2020. *The 2020 U.S. Energy and Employment Report*. National Association of State Energy Officials and Energy Futures Initiative. <https://static1.squarespace.com/static/5a98cf80ec4eb7c5cd928c61/t/5ee78423c6fcc20e01b83896/1592230956175/USEER+2020+0615.pdf> [accessed June 2020].
- NCCETC. 2016. Customer Credits for Monthly Net Excess Generation (NEG) Under Net Metering, Detailed Summary Maps, Database of State Incentives for Renewables and Efficiency® (DSIRE®). NC Clean Energy Technology Center. <http://ncsolarcen-prod.s3.amazonaws.com/wp-content/uploads/2019/07/NEG-1.20161.pdf> [accessed April 2020].

- NCCETC. 2017a. Expedited Permitting Process for Solar Photovoltaic Systems. NC Clean Energy Technology Center. <https://programs.dsireusa.org/system/program/detail/5293> [accessed May 2020].
- NCCETC. 2017b. Balancing Agricultural Productivity With Ground-Based Solar Photovoltaic (PV) Development. NC Clean Energy Technology Center. <https://nccleantech.ncsu.edu/wp-content/uploads/2018/10/Balancing-Ag-and-Solar-final-version-update.pdf> [accessed April 2020].
- NCCETC. 2017c. *Health and Safety Impacts of Solar Photovoltaics*. NC Clean Energy Technology Center. <https://nccleantech.ncsu.edu/wp-content/uploads/2019/10/Health-and-Safety-Impacts-of-Solar-Photovoltaics-PV.pdf> [accessed August 2020].
- NCCETC. 2018a. Modified Accelerated Cost-Recovery System (MACRS). NC Clean Energy Technology Center. <https://programs.dsireusa.org/system/program/detail/676> [accessed March 2020].
- NCCETC. 2018b. Solar Energy, Small Hydropower, and Geothermal Tax Credit (Personal). NC Clean Energy Technology Center. <https://programs.dsireusa.org/system/program/detail/1803> [accessed May 2020].
- NCCETC. 2019a. Solar and Wind Equipment Sales Tax Exemption. NC Clean Energy Technology Center. <https://programs.dsireusa.org/system/program/detail/119> [accessed May 2020].
- NCCETC. 2019b. Renewable Energy Systems Exemption. NC Clean Energy Technology Center. <https://programs.dsireusa.org/system/program/detail/165> [accessed May 2020].
- NCCETC. 2019c. 3rd Party Solar PV Power Purchase Agreement (PPA), Detailed Summary Maps, DSIRE®. NC Clean Energy Technology Center. http://ncsolarcen-prod.s3.amazonaws.com/wp-content/uploads/2019/07/DSIRE_3rd-Party-PPA_June_2019.pdf [accessed April 2020].
- NCCETC. 2020a. DSIRE®. NC Clean Energy Technology Center. <https://www.dsireusa.org/> [accessed April 2020].
- NCCETC. 2020b. Federal Programs, DSIRE®. NC Clean Energy Technology Center. <https://programs.dsireusa.org/system/program?state=US> [accessed April 2020].
- NorthWestern Energy. 2016. *The Montana Consumer Guide to Solar Heating Systems*. <http://bsd.dli.mt.gov/Portals/53/Documents/Building-Codes-Permits/dli-bsd-bc074.pdf?ver=2016-07-08-115012-177> [accessed April 2020].
- NREL. 2011. *A Review of Operational Water Consumption and Withdrawal Factors for Electricity Generating Technologies*. National Renewable Energy Laboratory. <https://www.nrel.gov/docs/fy11osti/50900.pdf> [accessed August 2020].
- NREL. 2013. *Land-Use Requirements for Solar Power Plants in the United States*. National Renewable Energy Laboratory. <https://www.nrel.gov/docs/fy13osti/56290.pdf> [accessed April 2020].
- NREL. 2016. *Distributed Generation Renewable Energy Estimate of Costs*. National Renewable Energy Laboratory. <https://www.nrel.gov/analysis/tech-lcoe-re-cost-est.html> [accessed April 2020].
- NREL. 2017. *Installed Cost Benchmarks and Deployment Barriers for Residential Solar Photovoltaics With Energy Storage: Q1 2016*. National Renewable Energy Laboratory. <https://www.nrel.gov/docs/fy17osti/67474.pdf> [accessed April 2020].
- NREL. 2018a. *U.S. Solar Photovoltaic System Cost Benchmark: Q1 2018*. National Renewable Energy Laboratory. <https://www.nrel.gov/docs/fy19osti/72399.pdf> [accessed April 2020].
- NREL. 2018b. *Global Horizontal Solar Irradiance: National Solar Radiation Database Physical Solar Model*. National Renewable Energy Laboratory. <https://www.nrel.gov/gis/assets/images/solar-annual-ghi-2018-usa-scale-01.jpg> [accessed March 2020].
- NREL. 2018c. *2018 U.S. Utility-Scale Photovoltaics-Plus-Energy Storage System Costs Benchmark*. National Renewable Energy Laboratory. <https://www.nrel.gov/docs/fy19osti/71714.pdf> [accessed April 2020].
- NREL. 2018d. *Federal Tax Incentives for Energy Storage Systems*. National Renewable Energy Laboratory. <https://www.nrel.gov/docs/fy18osti/70384.pdf> [accessed April 2020].
- NREL. 2019a. *The Potential Role of Concentrating Solar Power Within the Context of DOE's 2030 Solar Cost Targets*. National Renewable Energy Laboratory. <https://www.nrel.gov/docs/fy19osti/71912.pdf> [accessed April 2020].
- NREL. 2019b. *Beneath Solar Panels, the Seeds of Opportunity Sprout*. National Renewable Energy Laboratory. <https://www.nrel.gov/news/features/2019/beneath-solar-panels-the-seeds-of-opportunity-sprout.html> [accessed April 2020].
- NREL. 2019c. *Q4 2018/Q1 2019 Solar Industry Update*. National Renewable Energy Laboratory. <https://www.nrel.gov/docs/fy19osti/73992.pdf> [accessed April 2020].
- NREL. 2020. *PVWatts® Calculator*. National Renewable Energy Laboratory. <https://pvwatts.nrel.gov/> [accessed January 2020].

- NYSERDA. 2015. *Intro to Solar Policy*. NY-SUN PV Trainers Network, New York State Energy Research and Development Authority. <http://www.ongov.net/planning/documents/F.IntroductiontoSolarPolicy.pdf> [accessed April 2020].
- NYSERDA. 2020. NY-Sun (Solar Initiative). New York State Energy Research and Development Authority. <https://www.nyserdera.ny.gov/All-Programs/Programs/NY-Sun> [accessed May 2020].
- Penn State. 2018. *Active Solar Heating Systems*. Pennsylvania State University. <https://www.e-education.psu.edu/egee102/node/2097> [accessed April 2020].
- PNNL. 2019. *Energy Storage Technology and Cost Characterization Report*. Pacific Northwest National Laboratory. <https://energystorage.pnnl.gov/pdf/PNNL-28866.pdf> [accessed April 2020].
- Sandia. 2015. *DOE/EPRI Electricity Storage Handbook in Collaboration With NRECA*. Sandia National Laboratories. <https://prod-ng.sandia.gov/techlib-noauth/access-control.cgi/2015/151002.pdf> [accessed April 2020].
- SDG&E. n.d. *Technical Potential for Rooftop Photovoltaics in the San Diego Region*. University of San Diego School of Law and San Diego Gas & Electric. https://www.sandiego.edu/law/documents/centers/epic/060309_ASESPVPotentialPaperFINAL_000.pdf [accessed April 2020].
- SEIA. 2018. *Solar Investment Tax Credit (ITC)*. Solar Energy Industries Association. <https://seia.org/sites/default/files/inline-files/SEIA-ITC-101-Factsheet-2018-June.pdf> [accessed April 2020].
- SEIA. 2020a. *Solar Heating & Cooling*. Solar Energy Industries Association. <https://www.seia.org/initiatives/solar-heating-cooling> [accessed April 2020].
- SEIA. 2020b. *Community Solar*. Solar Energy Industries Association. <https://www.seia.org/initiatives/community-solar> [accessed April 2020].
- SRCC. 2015. *Solar Hot Water*. Solar Rating & Certification Corporation. <https://www.nist.gov/system/files/documents/iaao/Huggins.pdf> [accessed April 2020].
- UMass. 2018. *Dual-Use: Crop and Livestock Considerations*. University of Massachusetts at Amherst, The Center for Agriculture, Food, and the Environment. https://ag.umass.edu/sites/ag.umass.edu/files/factsheets/pdf/crop_and_livestock_considerations_110118.pdf [accessed April 2020].
- USDA. 2010. *Design of Small Photovoltaic (PV) Solar-Powered Water Pump Systems*. U.S. Department of Agriculture. https://www.nrcs.usda.gov/Internet/FSE_DOCUMENTS/nrcs142p2_046471.pdf [accessed April 2020].
- USDA. 2011. *Solar Energy Use in U.S. Agriculture: Overview and Policy Issues*. U.S. Department of Agriculture. https://www.usda.gov/oce/reports/energy/Web_SolarEnergy_combined.pdf [accessed April 2020].
- USDA. 2013. *Factors Affecting the Adoption of Wind & Solar Generating Systems on U.S. Farms: Experiences at the State Level*. U.S. Department of Agriculture. https://www.usda.gov/oce/reports/energy/WindSolar_Web_08162013.pdf [accessed April 2020].
- USDA. 2017. *Undersecretary Says Renewable Energy Production Promotes America's Security, Boosts Economy*. U.S. Department of Agriculture. <https://www.usda.gov/media/blog/2011/06/09/undersecretary-says-renewable-energy-production-promotes-americas-security> [accessed April 2020].
- USDA. 2019. *2017 Census of Agriculture: United States Summary and State Data, Volume 1, Geographic Area Series, Part 51*. U.S. Department of Agriculture. https://www.nass.usda.gov/Publications/AgCensus/2017/Full_Report/Volume_1,_Chapter_1_US/usv1.pdf [accessed April 2020].
- USDA. 2020. *Rural Energy for America Program Renewable Energy Systems & Energy Efficiency Improvement Guaranteed Loans & Grants*. U.S. Department of Agriculture. <https://www.rd.usda.gov/programs-services/rural-energy-america-program-renewable-energy-systems-energy-efficiency> [accessed April 2020].
- UVM. 2018. *Saffron and Solar Farms: A Win/Win for the Environment and Agriculture*. North American Center for Saffron Research and Development, University of Vermont. <https://www.uvm.edu/~saffron/Workshops/Saffron%20Workshop%202019/Saffron%20&%20Solar%20-%20Arash%20Ghalehgolabbahani.pdf> [accessed May 2020].
- Vermont. 2020. *On-Farm Renewable Energy*. Agency of Agriculture, Food and Markets, State of Vermont. <https://agriculture.vermont.gov/content/widget/farm-renewable-energy> [accessed April 2020].
- Windustry. 2020. *FAQ: How Much Do Farmers Get Paid to Host Wind Turbines?* http://www.windustry.org/how_much_do_farmers_get_paid_to_host_wind_turbines [accessed March 2020].
- WoodMac. 2019. *U.S. Energy Storage Monitor: 2018 Year in Review and Q1 2019 Executive Summary*. Wood Mackenzie Power & Renewables and the Energy Storage Association. <https://www.woodmac.com/research/products/power-and-renewables/us-energy-storage-monitor/> [accessed April 2020].

5. Wind Energy

INTRODUCTION

The scale of the wind electricity generation industry in the United States has grown more than fortyfold in the past 19 years, from 2,502 megawatts (MW) of installed capacity in 2000 to 105,583 MW in 2019 (AWEA, 2020a, p. 5). That growth has elevated wind's share of total U.S. electricity production from less than 1 percent in 2000 to 7 percent currently (EIA, 2020a). Several factors have driven that growth, including Federal and State policy support, enhancements in wind turbine technologies, and declines in wind energy system costs. In many parts of the United States, wind systems now produce electricity at lower overall cost than any other technology, thereby reducing power costs for business and residential consumers.

Within rural America where wind energy systems tend to be located, there has been a positive economic effect related to land rentals. For example, rural landowners received \$289 million in lease income from wind systems in 2018 (DOE, 2019a). Additionally, this income tends to be stable because land leases for wind systems typically last 20 to 40 years.

Almost 99 percent of the wind electricity generation capacity in the United States is comprised of large “utility-scale” systems that are connected to high-voltage transmission grids. Only 1 percent represents “distributed wind” energy systems.¹⁷⁵ These smaller distributed wind systems are connected to local distribution utility grids, can have specialized agricultural applications including irrigation water pumping, and are briefly described at the end of this chapter (NREL, 2007, p. 2).¹⁷⁶

Utility-scale wind energy systems are comprised of one or more wind turbines with individual turbine generating capacities typically 2 MW or greater¹⁷⁷ and sell the electricity they produce directly to wholesale power markets via transmission network interconnections.¹⁷⁸

The six most important themes about utility-scale wind technologies for the U.S. agricultural and forestry sectors, and for rural America in general, are:

1. The quantity of electricity produced per turbine and per megawatt of turbine capacity continues to expand due to technology advancements (e.g., longer turbine blades can now be mounted higher off the ground where they can capture higher wind speeds, and turbines have improved efficiency in converting a given quantity of wind into electricity).
2. Over the past 8 years, average wind energy system capital costs have dropped significantly.¹⁷⁹
3. Improving system economics, due to these performance and cost reasons, have led to rapid growth in wind adoption.
4. This rapid growth has created a substantial new source of lease income for many rural landowners.

¹⁷⁵ The cumulative capacity of distributed wind projects was 1,127 MW in 2018, compared to approximately 96,000 MW for the overall wind market in the United States in 2018 and 105,583 MW in 2019 (DOE, 2019b, p. 3; AWEA, 2020a, p. 5).

¹⁷⁶ Transmission grids “are operated by a regional transmission organization, independent system operator (ISO), or ... a utility ... and consist of high-voltage power lines designed to carry power efficiently over long distances. Distribution (grids), operated exclusively by utilities, deliver power at lower voltages and over shorter distances to the consumer” (EPA, 2019, p. 2). Transmission lines typically carry power at 115,000 volts or more, sub-transmission lines at 34,500 volts to just above 100,000 volts, and distribution lines are often below 34,500 volts. For the purposes of this report, sub-transmission and transmission lines are grouped in the transmission grid.

¹⁷⁷ Virtually all new utility-scale wind projects in the United States are comprised of turbines of 2 to 5 MW (2,000 to 5,000 kilowatts) in capacity (AWEA, 2020a, p. 3), although smaller turbines can be in this category if they are interconnected with the transmission grid.

¹⁷⁸ Among utility-scale wind technologies, this chapter describes only “on-shore” applications that are located on land. “Off-shore” wind projects (located in oceans or lakes) are not included, both because they are still uncommon in the United States with only one operating off-shore project (with 30 MW of capacity) and because they do not intersect strongly with the agricultural and forestry sectors (DOE, 2019c, p. 7).

¹⁷⁹ In this report, “capital costs” reflect fully installed costs and include all equipment, labor, design and engineering, permitting, and other costs involved in deploying a new wind energy system.

5. While wind is cost-competitive with grid power in much of the United States, its adoption is not uniform. Differences in available wind resource, wholesale power prices, and State incentives cause widely different regional adoption patterns.
6. Federal and State incentives have played important roles in accelerating adoption. Perhaps the greatest challenge to extending wind energy growth is how much the upcoming decline in Federal incentives will impede investment.

These six themes are explored in the balance of this chapter, which has the following sections:

- a. A characterization of how the technology operates and recent innovations
- b. A summary of wind energy system adoption and costs, along with differences by region
- c. A description of the potential economic and environmental and land use impacts of wind system deployment
- d. An explanation of common ownership and financing models for wind energy systems
- e. A section describing the smaller distributed segment of the wind energy market
- f. An outlook on what challenges remain for continued growth in the wind energy market

Because battery storage technologies are increasingly being combined with wind systems, special issues related to wind + storage solutions are noted in this chapter and explored in greater detail in the energy storage section of chapter 4 on solar technologies.

TECHNOLOGY CHARACTERIZATION FOR UTILITY-SCALE SYSTEMS

This section describes utility-scale wind energy system design and operation. This description applies to both single-turbine utility-scale systems and extremely large wind farms with 100 or more turbines. The turbines described here and elsewhere in this chapter are the common upwind horizontal-axis type, usually with three blades that rotate like an airplane propeller at a 90-degree angle to the ground. There also are much less common vertical-axis turbines (Sandia, 2012).

Technology Configuration and Operation

The key components of utility-scale wind systems are:¹⁸⁰

- Blades that rotate when wind blows over them, converting wind energy to rotational energy.
- Tower to support the turbine components. The tower for larger turbines often rises to a “hub height”¹⁸¹ of 80 to 140 meters and typically is made of tubular steel.
- Nacelle, including shafts, gear box (if not a direct drive turbine), and generator, to convert rotational energy produced by the blades into alternating current (AC) electricity that is provided to the transmission or distribution grid, as well as the housing of those components.
- Other turbine components, including a yaw drive to keep the system oriented properly to the wind direction, a pitch system to manage rotation speed, and a controller to start and stop the turbine for safe operation.
- **“Balance of plant” equipment**, such as an anemometer to collect wind data, electrical wiring, foundation support for the tower, and transformers and other equipment to interconnect the turbine with the transmission or distribution grid.

¹⁸⁰ This component list is adapted from DOE, 2019d.

¹⁸¹ Hub height is the distance above the ground of the central rotor piece or “hub” to which the turbine blades are attached.

A basic schematic of an on-shore, utility-scale wind turbine system is found *exhibit 5-1*.

Historically, most utility-scale wind turbines have been between 1 and 4 MW of capacity, with a growing trend toward larger turbines. In 2019, 35 percent of wind energy systems in the development pipeline planned to use turbines of 3 MW or larger (AWEA, 2020a, p. 3).¹⁸²

Technology Examples

Photos of wind energy systems deployed in rural areas are shown in *exhibit 5-2* and *exhibit 5-3*.

EXHIBIT 5-1: Components of a Typical Utility-Scale Wind Turbine System

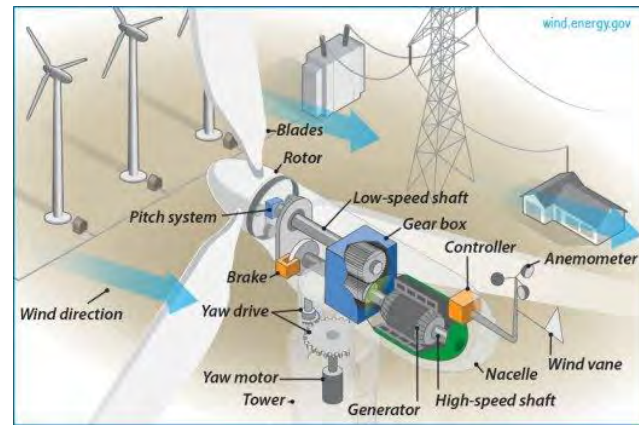

Source: DOE, 2019d.

EXHIBIT 5-2: Rural Utility-Scale Wind Energy System in Texas



Source: U.S. Department of State, 2017.

EXHIBIT 5-3: Rural Utility-Scale Wind Energy System in California



Source: AWEA, 2020b.

System Performance

Nationally, the performance of utility-scale wind projects continues to improve. The average capacity factor, which is a measure of how much of the generation potential of a power plant is being used, has increased by almost 75 percent over the past 16 years (DOE, 2019e, p. 37).¹⁸³ Specifically, the average capacity factor of wind projects by year of construction is as follows:

- 2014–2017: capacity factor = 42 percent
- 2004–2011: capacity factor = 31 percent
- 1998–2001: capacity factor = 24 percent

¹⁸² Wind projects are paired with energy storage (e.g., large battery systems), in some instances, to allow for more integration of variable renewable electricity into the grid, provide additional revenue streams, and/or increase system reliability. Wind + battery storage projects have been implemented in California, Hawaii, Illinois, Minnesota, and other locations (EEI, 2018).

¹⁸³ The capacity factor is calculated as annual electricity output in kilowatt-hours divided by the product of a generating asset's capacity in kilowatts multiplied by 8,760 hours (the number of hours in a non-leap year). A capacity factor of 100 percent indicates that a generating asset is operating at its full rated capacity every hour of the year. In practice, capacity factors are below 100 percent due to such activities as scheduled and unscheduled maintenance, mandatory or voluntary curtailments (shut-offs) of output, and, in the case of intermittent resources such as wind and solar, uneven availability of the natural resource powering the asset.

The reasons for the performance improvement include continuing trends toward longer blades able to catch more wind and higher hub heights allowing the turbine to utilize higher speed winds.¹⁸⁴ Larger blades are associated with more generating capacity and land leases of more acreage, other factors being equal.

Land Requirements

Utility-scale wind energy systems (or “projects”) typically require about 45 acres per megawatt of generating capacity,¹⁸⁵ or 135 acres for a 3-MW wind turbine. Often this land is leased from local farmers and other landowners. On average, a 20-MW wind project will require approximately 900 acres, although land requirements vary from project to project based on turbine blade length; turbine hub height; the number of turbines in the project; site topography; setbacks from nearby roads, homes, and transmission lines; required biologic and environmental remediation; and other factors.

Most of the acreage required by a utility-scale wind energy system is simply used to create space for the safe and efficient operation of the turbines (e.g., to maximize wind speed and direction through each turbine and avoid competition between turbines for wind resources [i.e., to avoid wake effects on downwind turbines]). If leased from a farm, for example, only about 1 acre per utility-scale turbine is removed from agricultural use during wind project operation, and 1 to 3 acres per turbine are removed temporarily during the project construction period (USGS, 2011, p. 16).

In comparison to wind energy systems, solar photovoltaic (PV) systems of the same capacity remove far more land from traditional farm use. This is because solar panels are mounted close to the ground in rows only wide enough to prevent self-shading between rows and to allow for operations and maintenance (O&M) access (roughly 10 feet between rows of a fixed-tilt PV system on level terrain) (HeliScope, 2020). In contrast, wind turbines are widely spaced and have blades that are often 65 feet to more than 200 feet off the ground at their lowest point. See chapter 4 for more discussion of utility-scale PV effects on farmlands.

CURRENT LEVEL AND COST OF ADOPTION AND REGIONAL DISTINCTIONS

While adoption of utility-scale wind energy systems continues to grow strongly, there is not a single, uniform wind market across the United States. As is the case with solar and other generation sources, the U.S. market for wind energy is a conglomeration of State and regional markets. Overall, wind systems account for more than 30 percent of all in-State power generation capacity in States such as Iowa, Kansas, and Oklahoma. In several other States, such as Arkansas, Connecticut, and Kentucky, however, wind's share of total generation capacity is less than 1 percent (EIA, 2019a).

Each of the following four factors, and their regional distinctions, affect wind energy adoption:

1. Wind resource
2. Capital and operating costs
3. Wholesale power prices
4. Policies for financial incentives

These factors are discussed below.

¹⁸⁴ For example, the U.S. Department of Energy notes that tower heights for new wind projects continue to increase and can be 140 meters off the ground (DOE, 2020). For a discussion of technology trends and other factors affecting wind project performance, see DOE, 2019e, pp. 24–48.

¹⁸⁵ This is a current average value for land requirements from the National Renewable Energy Laboratory (NREL, 2020). Older work by NREL puts average land use requirements for wind projects at 85 acres per megawatt of capacity (NREL, 2009, p. 10).

Wind Resource

The amount of wind available for electricity production varies among the 50 States, with the strongest on-shore wind resources in the Plains, Great Lakes, and California, and the lowest in the Southeast and coastal Mid-Atlantic. *Exhibit 5-4* displays wind resources across all States measured at 100 meters above the ground, with darker areas representing stronger resources.¹⁸⁶ Capturing stronger winds translates into greater annual electricity output from wind energy systems. Wind resources also can vary greatly within a State.

EXHIBIT 5-4: Wind Resources Across the United States at a Height of 100 Meters

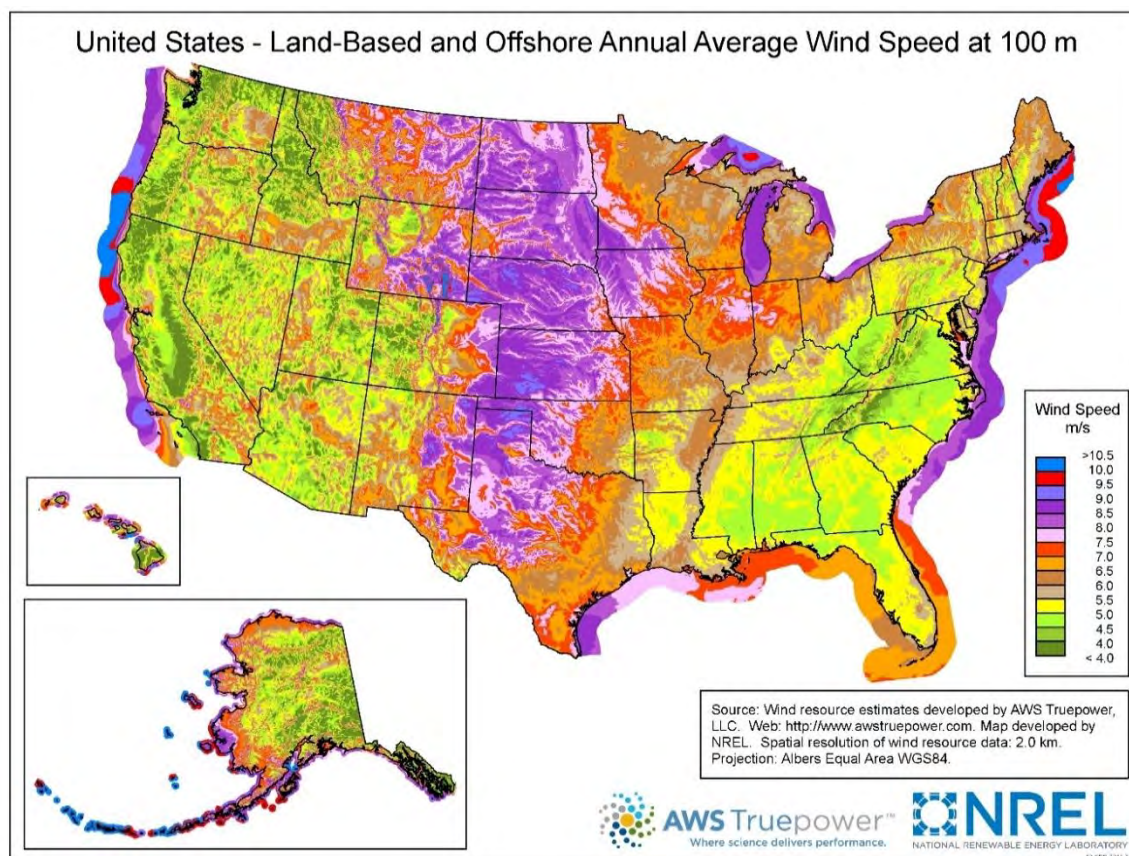

Source: NREL, 2013.

Due largely to the stronger wind resources in the interior of the country (e.g., Kansas, Oklahoma, and Texas) displayed in *exhibit 5-4*, the average utility-scale wind project in the interior produces roughly 38 percent more electricity annually on a per megawatt of capacity basis than the average project in the Northeast.¹⁸⁷ While wind resources may be lower than average in a given State, it still may be cost-effective to develop wind energy systems there. Factors discussed later in this section, including wholesale power prices and financial incentive policies, can more than compensate for less abundant wind resource availability.

The opposite also is true—having a rich wind resource does not guarantee a cost-effective wind project, even with wind capital costs being lower now than in the recent past. Land use restrictions, complex

¹⁸⁶ The strength of wind resources is typically measured at 80 to 100 meters above the ground because that is the hub height of many large-scale turbines and reflects the wind speeds they are able to capture.

¹⁸⁷ Specifically, the average capacity factor of wind projects built between 2014 and 2017 was 43.1 percent in the interior region and 31.3 percent in the Northeast United States (DOE, 2019e, p. 40).

environmental regulations, an oversupply of wind power leading to periodic curtailments of wind power output by the grid operator, low average wholesale power prices, and lack of State financial incentives can impair the economics of wind energy systems, even in areas with strong, steady winds.

Capital and Operating Costs

National Overview of Costs

Wind energy systems (like PV systems) require no fuel costs and have O&M costs that are low relative to capital costs. Consequently, their "capital cost" (or "installed cost") is the primary cost barrier to deployment. This is different than for many biomass-fueled energy generation technologies, for which feedstock costs are an important and ongoing cost factor.

Exhibit 5-5 lists typical capital and O&M costs for utility-scale, on-shore wind systems.^{188,189} The next three sections of this chapter provide more details on wind capital costs, O&M costs, and the levelized cost of energy (LCOE) metric used in this report to compare costs and performance across different renewable energy systems.

EXHIBIT 5-5: Summary of Utility-Scale Wind Energy System Capital and O&M Costs

System Type	Unit Capital Cost in \$/kW _{AC} (pre-incentive)	Typical Project Size (kW _{AC})	Total Capital Cost (pre-incentive)	Annual Fixed O&M Cost in \$/kW (in year 1 of system operation)
Large Multi-Turbine System	\$1,100 to \$1,500	100,000 to 150,000	\$110 MM to \$225 MM	\$26.22 to \$36.50

Sources: Lazard, 2019; EIA, 2020b.

National Capital Costs

Reported capital costs represent the full cost of designing, engineering, purchasing equipment, transporting equipment to the site, permitting, financing, constructing, and interconnecting with the grid. These capital costs are before any financial incentives that the wind system owner may secure. Wind systems built a decade ago tend to have operational lives of 20 to 25 years, while newly developed systems with advanced technical components have estimated asset lives of 30 or more years. In either case, the initial capital cost of the system is typically amortized over the expected asset life in long-term investment calculations (e.g., net present value).

A major reason for the sharp increase in the deployment of wind energy systems over the past decade has been declines in their capital costs (per megawatt of capacity). Currently, the total capital costs of utility-scale wind energy systems are about 40 percent lower than they were between 2009 and 2010 (DOE, 2019e, p. 51).

Regional Distinctions in Capital Costs

As shown in exhibit 5-6, capital costs ranged by region in 2018 from an average of about \$1,500 per kilowatt of capacity in the interior to just under \$2,000 per kilowatt in the West and about \$2,500 per kilowatt in the Northeast. Reasons for the cost differences include economies of scale (wind systems are more common in the interior and tend to be larger in that region), as well as flatter and less complex terrain for system construction in the interior (DOE, 2019e, p. 53). The small sample size of wind systems

¹⁸⁸ Investment bank Lazard lists capital costs for a 150-MW (150,000-kW) wind energy system at \$1,100 to \$1,500/kW (Lazard, 2019, p. 17). For comparison, the U.S. Energy Information Administration's capital costs for a 200-MW wind energy system are listed at \$1,319/kW, including contingency costs (EIA, 2020b, p. 2).

¹⁸⁹ Lazard's fixed O&M assumption for a 150-MW wind energy system is \$28.00 to \$36.50/kW-year (Lazard, 2019, p. 17), while the U.S. Energy Information Administration assumes these costs at \$26.22/kW-year for a 200-MW project (EIA, 2020b, p. 2). At an initial cost of \$26.22/kW-year, a 150-MW project would pay \$3.9 million in annual O&M costs. O&M costs typically rise each year with general price inflation.

outside of the interior also affects the predictive quality of the data. Of the sample wind energy capacity in *exhibit 5-6*, 80 percent is in the interior region.

EXHIBIT 5-6: Variance in Wind Energy Capital Costs for Utility-Scale Systems by Region



Source: DOE, 2019e, p. 53.

Operations and Maintenance (O&M) Costs

For utility-scale, on-shore wind energy systems, O&M costs are a less significant factor in project economics than capital costs, although still a meaningful factor. Wind system O&M costs cover activities such as turbine and substation preventive maintenance, replacement of system components as needed, system performance monitoring, and responding to wind system outages and emergencies. O&M cost metrics, depending on the methodology of the organization producing the metrics, may also include incremental annual property taxes and insurance premiums on the wind system itself (not the property on which the system is located) and land lease payments.

Wind energy systems, unlike biomass power generation systems, typically do not have large variable O&M costs (i.e., costs that vary with how much electricity is produced).

Levelized Cost of Energy (LCOE)

LCOE measures the cost of producing electricity over the life of a power generation system. The specific inputs to LCOE calculations for wind energy systems include capital cost (\$/kilowatt [kW]), fixed O&M cost (\$/kW-year), capacity factor (%), capital charge rate (%), cash flow from loans, and asset life (years).¹⁹⁰ LCOE sometimes excludes incentives and taxes. *Exhibit 5-7* summarizes LCOE for utility-scale wind energy systems.

EXHIBIT 5-7: Estimated LCOE for Utility-Scale Wind Energy Systems

System Type	LCOE Range (\$/kWh) Without Federal Incentives	LCOE Range (\$/kWh) With Federal Incentives
Large Multi-Turbine System	\$0.028 to \$0.054 (Lazard) \$0.037 (EIA)	\$0.011 to \$0.045 (Lazard) \$0.028 (EIA)

Sources: Lazard, 2019, p. 3; EIA, 2020c, p. 15.

Wholesale Power Prices

Exhibit 5-8 shows how average annual, on-peak wholesale electricity prices varied by region in recent years. For example, New England had the highest cost at \$0.052/kilowatt-hour (kWh) in 2018. The Northwest had the lowest cost at \$0.032/kWh that year, leading to a variation of 63 percent between

¹⁹⁰ For generation technologies that burn fuels (unlike wind systems), LCOE calculations typically include three additional items: fuel cost, variable O&M cost, and heat rate for converting fuel to electricity.

these regions.¹⁹¹ The price differences between regions narrowed in 2019 as seen in *exhibit 5-8*. That narrowing was due to constraints on a natural gas pipeline system raising electricity prices in the Northwest, and lower gas costs reducing electricity prices in other regions (EIA, 2020f).

EXHIBIT 5-8: Average On-Peak Wholesale Electricity Prices in Selected U.S. Regions

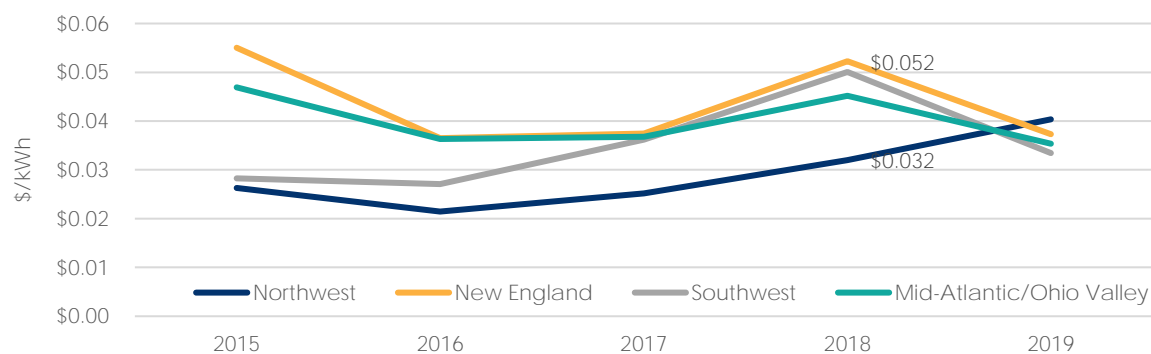

Source: Adapted from data available at EIA, 2020d.

Beyond average price levels, the timing of wholesale electricity prices in any market can affect the compensation to wind system owners. Wholesale power prices typically vary each hour (or on sub-hourly intervals in some markets) due to supply and demand factors, as well as market rules. This means that the annual, on-peak prices shown in *exhibit 5-8* are the average of several thousand separate prices in a year.

Similarly, power production from wind systems is not constant; it depends on the availability of the wind resource during any time interval. Wind systems often produce the most power in the evenings (Hoste, et al., 2011, p. 7) when wholesale power prices are low in many parts of the United States (due to decreased demand for power from homes and businesses). However, in certain markets, such as California, wholesale power prices are becoming lowest mid-day due to the growth of PV systems.

Policies for Financial Incentives

Overview

For wind energy systems, there are important Federal incentives (e.g., the production tax credit [PTC], accelerated depreciation, some U.S. Department of Agriculture [USDA] programs) that are uniformly available across the 50 States. There also is a wide range of State-level policies for wind system development, with some States having no financial incentives for wind, while others offer full or partial exemptions from taxes for wind systems, have renewable energy certificate (REC) markets to meet State Renewable Portfolio Standard (RPS) or Clean Energy Standard (CES) mandates, capital-based incentives, or loan programs.¹⁹²

Federal Incentive Policies

The main Federal financial incentive for utility-scale wind systems is the PTC, which is an inflation-adjusted tax credit for electricity generated from wind and certain other renewable energy systems

¹⁹¹ Prices are from the Intercontinental Exchange (ICE), an owner of financial and commodity market exchanges including those for energy, and they are the weighted average, by trading volume, of daily prices for the following four power trading hubs and pricing products: Mid-Columbia Peak (Northwest), Palo Verde Peak (Southwest), PJM Western Hub Real-Time Peak (Mid-Atlantic/Ohio Valley), and NEPOOL Massachusetts Hub Day-Ahead Peak (New England). To review historical ICE pricing data, see EIA, 2020d. On-peak periods are defined within each region and typically cover morning to mid/late evening hours on business days, while off-peak periods cover other times (late evenings through early morning during the business week and all day on weekends and holidays) and typically have lower average prices than on-peak periods (EIA, 2020e).

¹⁹² For detailed State-by-State incentive information, see the Database of State Incentives for Renewables & Efficiency® (www.dsireusa.org).

and was recently extended through 2020 (HR 1865, 2019). The PTC provides a tax benefit beginning at \$0.015/kWh for the first 10 years of operation as long as the wind energy system meets either of two requirements demonstrating project commencement before the end of 2020 (IRS, 2019, pp. 2–3).^{193,194} There are other starting PTC levels for systems that met requirements in prior years.

The historic importance of the PTC can be seen in *exhibit 5-9*, which shows the pattern of wind system deployment spikes before PTC expirations and returns to growth after PTC extensions.

EXHIBIT 5-9: Expiration and Extension History of the Federal Production Tax Credit for Wind Energy Systems (Through 2013)

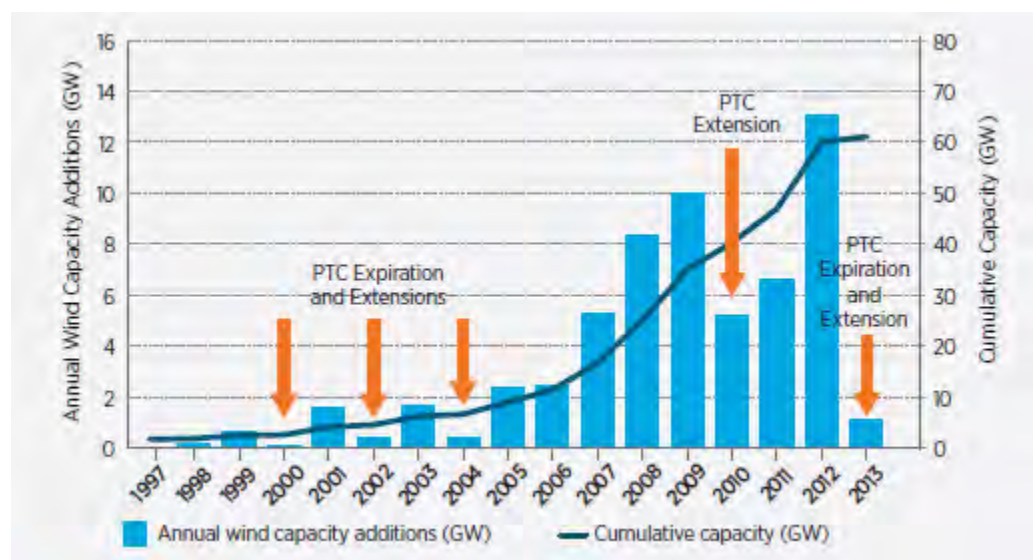

Source: DOE, 2015, p. xxxvi.

Wind energy systems also can receive tax depreciation benefits under the Modified Accelerated Cost-Recovery System (NCCETC, 2018). To be eligible for tax credits or accelerated depreciation, the wind system owner must be a tax-paying entity with sufficient tax liability to absorb the benefits.

There also are Federal loan guarantees and grants specific to rural America that are administered by USDA and that cover utility-scale and distributed wind technologies, as well as many other renewable technology types (USDA, 2020). For more information on USDA programs supporting renewable energy generation, see chapter 3.

State Incentive Policies

Among State policies, the most common and influential on wind energy deployment are RPS and CES. These policies set either goals or mandates in each State for the percentage of renewable electricity (or clean energy) that must be delivered to electricity consumers each year. They typically have percentages that increase annually until reaching the final goal or requirement, which can be as high as 100 percent renewables. The range of RPS and CES policies in the country is displayed in *exhibit 5-10*.¹⁹⁵

¹⁹³ The owner can establish that it commenced construction for PTC purposes “by starting physical work of a significant nature or by meeting the safe harbor” project expenditure requirements (CRS, 2018, p. 1).

¹⁹⁴ Wind energy systems can claim the Federal investment tax credit (with a phase-out schedule comparable to the PTC) in lieu of the PTC, but that is rarely done for utility-scale systems for economic reasons.

¹⁹⁵ The green states in the map denote states with Clean Energy Standards or goals that overlap with Renewable Portfolio Standards.

EXHIBIT 5-10: Renewable Portfolio Standard and Clean Energy Standard Policies by State

State	Renewable Portfolio Standard	Renewable Portfolio Goal	Clean Energy Standard	Clean Energy Goal	Details
Arizona	✓				15% x 2025
California	✓		✓		60% x 2030 (100% x 2045)
Colorado	✓			✓	30% by 2020 (IOUs) (100% x 2050)
Connecticut	✓				40% x 2030
District of Columbia					100% x 2032
Delaware	✓				25% x 2026
Hawaii	✓				100% x 2045
Iowa	✓				105 MW
Illinois	✓				25% x 2026
Indiana		✓			10% x 2025
Kansas		✓			20% x 2020
Massachusetts	✓				35% x 2030 + 1% each year thereafter (new resources)
Maryland	✓				50% x 2030
Maine	✓				100% x 2050
Michigan	✓				15% x 2021
Minnesota	✓				26.5% x 2025 (IOUs)
Missouri	✓				15% x 2021
Montana	✓				15% x 2015
North Carolina	✓				12.5% x 2021 (IOUs)
North Dakota		✓			10% x 2015
New Hampshire	✓				25.2% x 2025
New Jersey	✓				50% x 2030
New Mexico	✓		✓		80% x 2040 (IOUs) (100% x 2045 (IOUs))
Nevada	✓			✓	50% x 2030 (100% x 2050)
New York	✓				50% x 2030 (100% x 2050)
Ohio	✓				12.5% x 2026
Oklahoma		✓			15% x 2015
Oregon	✓				50% x 2040
Pennsylvania	✓				18% x 2021
Rhode Island	✓				38.5% x 2035
South Carolina		✓			2% x 2021
South Dakota		✓			10% x 2015
Texas	✓				5,880 MW x 2015
Utah		✓			20% x 2025
Virginia		✓			15% x 2025
Vermont	✓				75% x 2032
Washington	✓		✓		15% x 2020 (100% x 2045)
Wisconsin	✓				10% x 2015

Source: NCCETC, 2019.

States often have REC or similar accounting mechanisms to track RPS or CES progress. Sales of RECs become a potential revenue stream for the wind system owner.¹⁹⁶

States also incentivize wind power through enabling policies that allow for faster and lower cost interconnection of wind energy systems with power transmission systems, streamlined and predictable environmental review and approval processes, and the absence of significant land use restrictions. For a given wind energy system, these enabling policies can be the difference between the project being economically viable or unviable.¹⁹⁷

¹⁹⁶ Wind energy systems produce two types of outputs: (1) physical energy (which is physically the same as energy from non-renewable sources), and (2) environmental attributes that are accounting mechanisms to distinguish and track the renewable (environmental and social) benefits of the output. Environmental attributes, of which RECs are the most common type for electricity generation projects in the United States, can be traded in financial markets. If the wind system owner sells the RECs or other environmental attributes to improve system economics, then the owner cannot claim to be buying green power (EPA, 2020a).

¹⁹⁷ To review regional and State-level variation in enabling policies for grid interconnection, see IREC, 2020 and EPA, 2019.

Examples of State financial and enabling policies, beyond RPS and CES, encouraging large-scale wind energy development are listed in *exhibit 5-11*.

EXHIBIT 5-11: Examples of State-Level Financial and Enabling Policies for Wind Energy Systems

State	Incentive Name	Incentive Description
New Jersey	Wind Permitting Standards	Allows wind projects in industrial zones and near piers (NCCETC, 2014).
Ohio	Wind Permitting Standards	"Wind farms below 5 MW are considered neither major utility projects nor economically significant wind farms and are thus subject only to local ordinances and not state jurisdiction" (NCCETC, 2015a).
Texas	Franchise Tax Exemption	"Companies in Texas engaged solely in the business of manufacturing, selling, or installing solar or wind energy devices are exempt from the franchise tax" (NCCETC, 2015b).
West Virginia	Partial Business and Operation (B&O) Tax Exemption	"An effective B&O tax rate on wind powered turbines that is about 30 percent of the effective tax rate of most other types of newly constructed generating units" (NCCETC, 2015c).

Source: NCCETC, 2020.

Aggregate Regional Effects

The aggregate result of the four deployment factors above is reflected in the wind energy deployment patterns in *exhibit 5-12*.

EXHIBIT 5-12: Wind Energy Generation Capacity by State (MW_{AC})

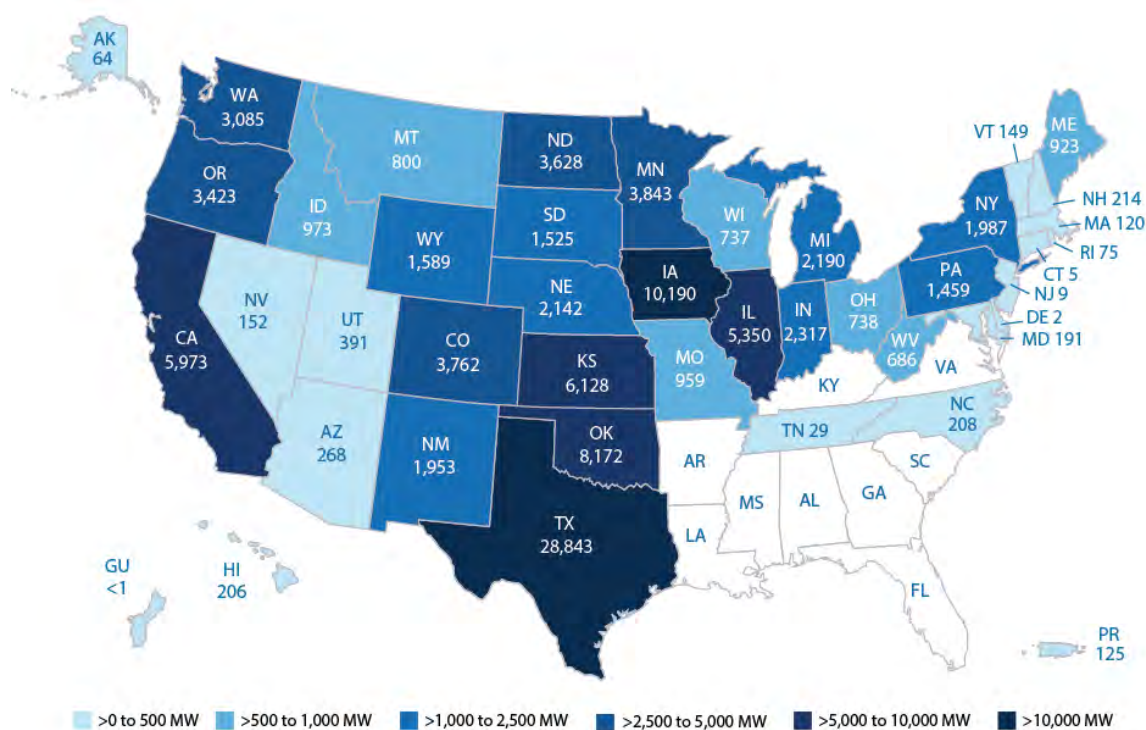

Source: AWEA, 2020a, p. 8.

Adoption Impacts for Utility-Scale Systems

Deployment of utility-scale wind energy systems can have the following potential economic, environmental, and land use impacts on households, farms and other businesses, and rural communities:

1. Land lease payments
2. Reduced greenhouse gas (GHG) emissions
3. Potential negative environmental and land use impacts
4. Employment
5. Lower wholesale electricity prices

Each of these benefits is described below.

Land Lease Payments

Payments to rural landowners on which wind energy systems are located can be substantial (approximately \$3,000 to \$4,000 annually per megawatt of wind generation capacity) and of long duration (Windustry, 2020; Kansas City Fed, 2013, p. 7).¹⁹⁸ These lease payments are predictable and stable over time as are many government agricultural payments. In addition, typical agricultural land uses are often unaffected or only modestly affected by the construction and operation of utility-scale wind turbines.

A main reason that land lease payments tend to be large is that they compensate landowners for accepting long-run obligations on large areas of land, which may reduce the number of potential buyers should the owner desire to sell the land within the lease term.¹⁹⁹ For land in commodity production, however, the land use restrictions themselves are generally not burdensome as most of the leased land can remain in its prior use.

For example, a typical single, 3-MW turbine with a hub height of 80 to 100 meters requires about 135 acres of land to optimize wind collection and safely operate (NREL, 2020). However, the ground footprint of the same wind turbine is only about 1 acre. That leaves 99 percent of the land that will need to be leased by the wind system owner unaffected during the operational life of the project, except during times of significant O&M activities.

During the approximately 9- to 15-month overall on-site construction process for large wind systems, there is further land disrupted to allow for transportation of major equipment and other materials to the site, storage of equipment and materials, continued site access from construction staff, and the project assembly or installation activities themselves, including the use of large cranes.

Brule County Wind, South Dakota

This wind system, which became operational in October 2018 near the town of Kimball, South Dakota, is a typical example of a utility-scale wind energy system on rural lands. The total capacity of the project is 20.7 MW, comprised of nine General Electric turbines of 2.3 MW each.

The system spreads across the properties of three landowners, including a land and cattle company. The electricity produced by the wind farm is being purchased by the local utility—NorthWestern Energy—and is being used to serve the utility's customers (Mitchell Republic, 2018).

¹⁹⁸ Lease payments in the Kansas City Fed source were per turbine and have been converted to approximate per acre equivalents based on average turbine size at the time of that report.

¹⁹⁹ Typically, these leases require that (1) all obligations transfer to successor landowners, and (2) those successors have adequate creditworthiness.

In addition to the local revenue to the landowner from lease payments, there can be local (county-level) increases in employment, on average, for each new megawatt of wind energy capacity deployed (Brown, et al., 2012, p. 26).

While wind energy systems are deployed on many types of lands (see *exhibit 5-13*), they are most common on croplands and rangelands, and uncommon on forest lands. On a generating capacity (MW) basis, about 47 percent of wind turbines are installed on croplands and 46 percent are installed on rangelands (USDA, 2017, table 7). On rangelands, wind turbines tend to be almost evenly divided among shrublands and grasslands/pasture (USDA, 2017, table 7).

Lease payments for wind energy systems are typically structured on a fixed-fee basis, a royalty basis, or a hybrid of fixed and royalty payments.²⁰⁰ Leases of agricultural land for wind systems that have been commissioned are often 20 to 40 years to cover the full operating life of the project. Much shorter leases, with options for the wind energy developer to extend the leases, will typically be put in place at early stages in development (i.e., before the wind energy system becomes operational).

Participation in wind system leases is already high, with the *Census of Agriculture* reporting that 20,072 farms received such payments in 2017, up 97 percent since 2012 (USDA, 2019, p. 60).²⁰¹ In total, "during 2018, wind energy projects on private land provided \$289 million in land lease payments to rural landowners" (DOE, 2019a).

Although some rural citizens express dissatisfaction with having agricultural lands with wind turbines nearby, studies often find that prices for homes and lands near wind systems are not negatively affected by the presence of wind turbines (LBNL, 2013; Shultz, et al., 2015).

EXHIBIT 5-13: Wind Turbine Distribution by Land Cover Type (data in MW of wind generating capacity)

Land Cover Type	All Turbines Based on 2014 CDL				
	Total	Number	Average	Sum	Percent
All Land Cover		49,454	1.40	69,074	100.00%
General Categories	Number	Average	Sum	Percent	
Cropland	19,208	1.68	32,210	46.63%	
Rangeland	26,919	1.19	31,906	46.19%	
Forest	1,961	1.85	3,626	5.25%	
Wetland	117	0.47	55	0.08%	
Barren	904	0.80	723	1.05%	
Open Water	2	1.30	3	0.00%	
Developed	343	1.61	552	0.80%	
Detailed Categories	Number	Average	Sum	Percent	
Corn	5,856	1.62	9,487	13.73%	
Cotton	1,319	1.63	2,152	3.12%	
Sorghum	575	1.89	1,089	1.58%	
Soybeans	4,570	1.65	7,562	10.95%	
Spring Wheat	415	1.84	765	1.11%	
Winter Wheat	2,977	1.77	5,258	7.61%	
Alfalfa	403	1.56	629	0.91%	
Other Hay/Non-Alfalfa	331	1.81	599	0.87%	
Fallow/Idle Cropland	1,788	1.69	3,017	4.37%	
Developed/Open Space	228	1.58	361	0.52%	
Developed/Low Intensity	54	1.74	94	0.14%	
Developed/Med Intensity	46	1.76	81	0.12%	
Developed/High Intensity	15	1.07	16	0.02%	
Barren	904	0.80	723	1.05%	
Deciduous Forest	1,728	1.83	3,160	4.57%	
Evergreen Forest	182	2.01	365	0.53%	
Mixed Forest	51	1.99	101	0.15%	
Shrubland	12,824	1.21	15,466	22.39%	
Grass/Pasture	14,095	1.17	16,441	23.80%	
Triticale	48	1.83	88	0.13%	

Note: Selected land cover categories presented may not add up to 100%.

Source: USDA, 2017, table 7.

²⁰⁰ Lease payments to landowners can be structured as fixed fees, or as royalty payments varying with the value of the wind electricity sold. Fixed fees can be paid monthly, quarterly, or annually, and they can be based on acreage, number of turbines, or wind system capacity. Royalty-based leases provide the landowner with a portion of the revenue produced by the wind system (NYSERDA, 2017, pp. 7–8).

²⁰¹ Farms leasing their wind rights vary widely in their size of agricultural operations, with more than 600 farms in each of the USDA's 11 size categories (market value of agricultural products sold) receiving payments in 2017 (USDA, 2019, pp. 128–129).

Reduced GHG Emissions

Lower GHG emissions compared to average grid mix power are delivered from almost all wind energy systems, as they are for solar and other renewable energy sources. The only instances where they would not reduce GHG emissions are when the electricity they generate displaces electricity generated by nuclear or 100 percent renewable power plants (e.g., a market supplied entirely by hydropower).

The GHG emission reductions expected from a prototypical, new 10-MW wind energy system in three States—Kentucky, Florida, and Washington State—are displayed in *exhibit 5-14*.^{202,203,204} The emission reductions in these States differ because the carbon intensity of the States' electricity grids is very different.

Kentucky has a coal-intensive electricity generation mix, which is why emission reductions from a wind system in that State, other factors being equal, are much higher than in the other example States. On the other extreme, most of Washington State's generation mix is from zero carbon emissions hydropower, meaning that the introduction of a new wind system will have a less significant effect on grid emissions than in most other States.²⁰⁵

In *exhibit 5-14*, GHG reductions are shown for an illustrative 10-MW wind energy project in Kentucky, Florida, and Washington State. Reductions are displayed in metric tons of carbon dioxide equivalent (CO₂e)²⁰⁶ removed from the electric grid, as well as two equivalent GHG reduction metrics.

EXHIBIT 5-14: Estimated Annual GHG Reductions and Equivalencies From 10-MW Wind Energy Systems in Selected States

State	Annual GHG Emission Reductions (metric tons of CO ₂ e) ^{equivalent} [CO ₂ e]	Equivalent Reduction in Number of Passenger Vehicles	Equivalent Reduction in Number of Homes Using Energy
Kentucky	25,385	5,484	2,929
Florida	13,106	2,831	1,512
Washington	2,765	597	319

Sources: EPA, 2020b, p. 4; EPA, 2020c; EIA, 2020g.

²⁰² A 10-MW system size was utilized here for comparability to the results in the bioelectricity and solar chapters of this report, which also use a 10-MW project as the basis for their GHG examples. Because the average capacity factor of wind energy systems is higher than for solar energy systems, GHG emission reductions from wind systems are also greater.

²⁰³ The GHG emission reduction calculations underlying this exhibit are as follows: 10-MW wind system capacity multiplied by an assumed 34.8 percent capacity factor multiplied by 8,760 hours in a non-leap year = 30,485 megawatt-hours (MWh) of electricity output from the wind system in a year. The wind capacity factor is a U.S. average for 2019 (EIA, 2020g). State-level emissions factors of CO₂ equivalent (CO₂e) from the U.S. Environmental Protection Agency (EPA, 2020b, p. 4) are converted from pounds/MWh to metric tons/MWh at a ratio of 2,204.623 pounds per metric ton to yield emissions factors of 0.8327, 0.4299, and 0.0907 metric tons of CO₂e/MWh for Kentucky, Florida, and Washington State, respectively. These State-level emissions factors are then multiplied by the annual electricity output of 30,485 MWh to obtain the emission reduction from the 10-MW wind systems in each State.

²⁰⁴ EPA's Greenhouse Gas Equivalencies Calculator was used to convert annual GHG reductions from the wind systems into equivalent GHG savings from removing passenger cars from the road for a year and removing homes' energy use for a year (EPA, 2020c).

²⁰⁵ The strength of the wind resource also will affect GHG emission reductions as it will differ, on average, from State-to-State and differ from individual site-to-site. For this example, a constant wind capacity factor for all three States was applied so that the differences in carbon content of the State's electricity generation mix are clearly shown.

²⁰⁶ In EPA's eGRID database, CO₂e is a summary measure that expresses the combined impact of three greenhouse gases—carbon dioxide (CO₂), methane (CH₄), and nitrous oxide (N₂O)—as an equivalent CO₂ impact. For more information on CO₂e calculations, see EPA, 2012.

Potential Negative Environmental and Land Use Impacts

While wind energy systems reduce GHG and other air emissions compared to conventional generating technologies and use almost no water during their operation (NREL, 2011, p. 12), they can cause other types of negative impacts on land use and the environment.

For example, the transport of increasingly large wind turbines to installation sites often requires the construction of service roads that may disrupt the environment (EIA, 2019b). The growth in the number of wind energy systems also can increase the mortality of birds and bats (due to collisions of these animals with turbines) and disrupt bird migration patterns (USFWS, 2018).²⁰⁷

Like PV technologies, electricity from wind energy systems is produced intermittently. Battery storage can be incorporated into wind systems to stably integrate more of their power into electricity grids. If battery technologies become more widespread in wind systems, more hazardous materials (primarily lead and lithium) will likely be needed to manufacture the batteries. To avoid associated environmental damages, used batteries must be recycled or disposed of properly (EPA, 2018). Wind energy system construction can also necessitate transmission and distribution power line extensions, which may disrupt habitat and increase bird and bat mortality.

Employment

With the increase in deployment of wind energy systems, the wind energy industry has become an important and growing source of employment. In 2019, there were 114,774 workers in this industry, 3 percent more than in the prior year (NASEO, 2020, p. 60). As shown in *exhibit 5-15*, construction jobs accounted for the greatest number of workers.

Lower Wholesale Electricity Prices

Reductions in wholesale prices are achieved in a market if the cost of wind electricity production is less than other alternatives. For example, Colorado's largest electric utility conducted a request for proposals to obtain low-cost, reliable electricity to add to its supply mix in late 2017. The result was that the median bid price for wind projects was \$0.0181/kWh, and the median price for wind with battery storage was \$0.0210/kWh (Xcel Energy, 2017, p. 9). Those prices are below Colorado's typical wholesale power costs. Increasing the deployment of wind energy systems also is associated with reduced wholesale power prices in Oklahoma, Texas, and other regions (LBNL, 2019, pp. 36–38).

DOMINANT OWNERSHIP/FINANCING MODEL FOR UTILITY-SCALE SYSTEMS

There are broadly two ownership models for utility-scale wind energy systems:

1. Self-Ownership typically involves an electric utility owning the equity in a wind energy system, with or without outside loans, and using the output from the system to serve its customers. This model is much more common in vertically integrated utility markets where utilities can own the power

EXHIBIT 5-15: Wind Energy Employment by Sector in the United States

Sector Within Wind Industry	2019 Employment	Sector Share of Employment
Construction	37,910	33.0%
Professional and Business Services	28,873	25.2%
Manufacturing	26,408	23.0%
Wholesale Trade	12,305	10.7%
Utilities	6,360	5.5%
Other	2,918	2.5%
TOTAL	114,774	100.0%

Source: NASEO, 2020, p. 60.

²⁰⁷ The Federal government and the wind industry continue to research methods for reducing the negative effects of wind turbines on birds and bats (DOE 2019f; EIA, 2019b).

generation facilities than in “competitive” or “deregulated” electricity markets in which utilities usually do not own these facilities.²⁰⁸

2. External Ownership means that one or more outside investors own a controlling interest, and the wind system’s power output is sold in the wholesale market (e.g., to the utility or a competitive generation supplier), or directly to a large end-use customer (such as a data center) typically also via a wholesale market transaction. For external ownership transactions, there is usually a power purchase agreement of 10 years or longer specifying the prices at which power from the wind system will be sold.²⁰⁹

DISTRIBUTED WIND ENERGY SYSTEMS

Because 99 percent of U.S. wind energy capacity is comprised of utility-scale systems, the prior material in this chapter pertains exclusively to utility-scale systems, unless otherwise noted. This section contains a brief description of distributed wind energy systems that comprise the remaining 1 percent of the market.

The distributed wind energy market is comprised of three segments (DOE, 2019b, p. 1):

- a. Large turbine systems: Individual turbines above 1,000 kW in capacity
- b. Mid-sized turbine systems: Individual turbines of 101 to 1,000 kW in capacity
- c. Small turbine systems: Individual turbines of 1 to 100 kW in capacity

Technology Description

The technologies used for distributed wind energy systems tend to operate in a similar manner to utility-scale projects as horizontal axis systems with multiple blades. However, most distributed wind systems have shorter blades and lower hub heights than utility-scale systems, which decrease their performance (average annual electricity output per unit of system capacity) relative to utility-scale systems. The smallest residential- or small commercial-scale wind systems of 10 kW or less in capacity have blades that are 1/10th as long as the largest distributed wind systems (NREL, 2016, p. 10). Representative project turbine heights and rotor radius (a synonym for blade) dimensions for distributed wind systems are listed in *exhibit 5-16*.

EXHIBIT 5-16: Turbine Size Characteristics for Distributed Wind Energy Systems

System Size (kW)	Allowable Hub Heights (meters [m])	Rotor Radius (m)
2.5	20, 30, 40	2.2
5	30, 40	3.1
10	30, 40	4.4
20	30, 40, 50	6.2
50	30, 40, 50	9.8
100	40, 50	13.8
250	50	21.9
500	50, 80	30.9
750	50, 80	37.8
1,000	50, 80	43.7
1,500	80	53.5

Source: NREL, 2016, p. 10.

Market Size by Segment

Wind energy systems in the large turbine segment are like utility-scale systems, except that they are, by definition, interconnected to the utility distribution grid instead of the transmission grid and are typically smaller in total capacity. Wind energy system owners may choose to interconnect to the distribution grid for several reasons, including access to higher power prices for output (e.g., from a utility, community wind program, or end-use electricity customer), special utility procurement programs at the distribution level, absence of nearby transmission interconnection capacity, or favorable siting or other project characteristics near the distribution point of interconnection.

²⁰⁸ Competitive electricity generation markets are common in the Mid-Atlantic and Northeast United States, some Great Lakes States, and portions of Texas and California. For more information on this topic, see ElectricChoice.com, 2018.

²⁰⁹ There are some cases of wind energy systems owned by independent power producers not having long-term, fixed-price contracts and selling power into the local spot electricity market.

As shown in *exhibit 5-17*, the large turbine segment comprised 94 percent of new distributed wind systems in 2018 (DOE, 2019b, p. 7). The reason for the prevalence of the large turbine segment within the distributed wind market is economics: this segment has much lower unit capital costs, as well as better performance, than the mid-sized and small turbine segments.²¹⁰

EXHIBIT 5-17: U.S. Distributed Wind Energy System Capacity by Segment

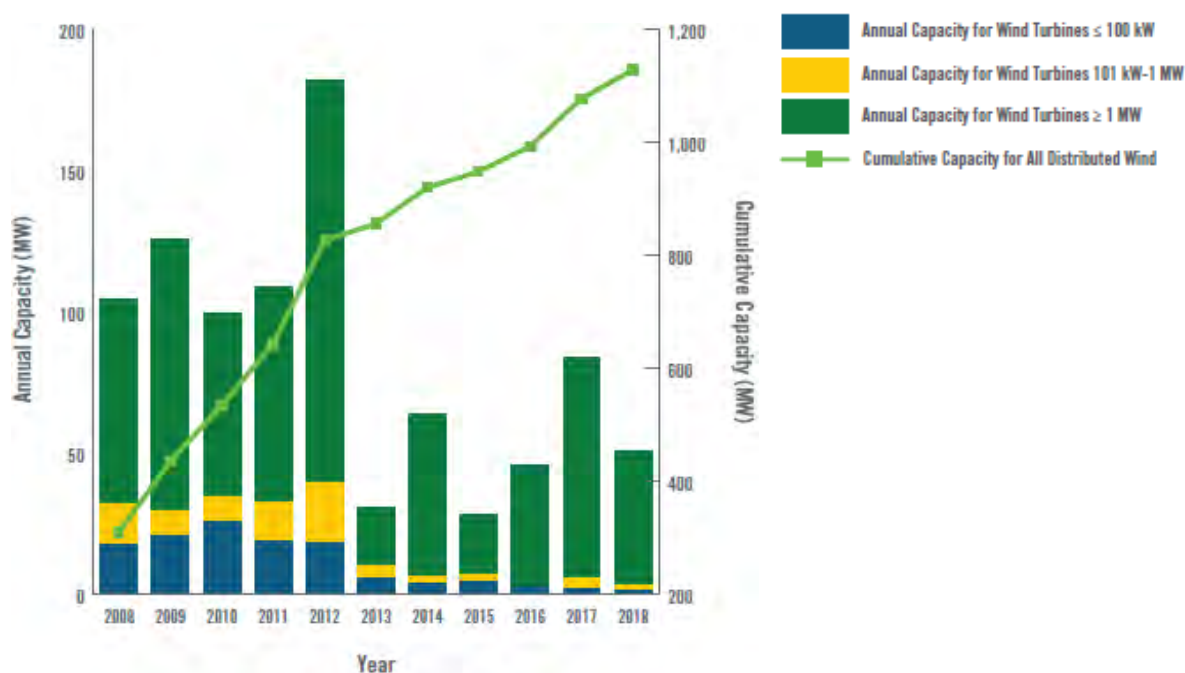

Figure 1. U.S. distributed wind capacity

Source: DOE, 2019b, p. 3.

The mid-sized turbine segment, together with the small turbine segment, comprise the equivalent of the “entity-scale” wind energy market that directly supplies electricity to businesses and households through on-site or adjacent systems. On a relative basis, this entity-scale wind energy market (with combined, new 2018 capacity of 3 MW) is much smaller than the entity-scale market for PV and biomass electricity generation, and its growth has slowed in recent years (DOE, 2019b, pp. 3–7). System capital costs in the mid-sized turbine market tend to be about \$2,500 to \$5,700 per kilowatt, with bigger systems having lower unit costs (NREL, 2016, p. 15).

Per unit capital costs in the small turbine segment tend to be high, at average levels of about \$10,000 per kilowatt for the smallest (residential) systems (DOE, 2019b, p. 20). For systems between 10 and 100 kW in capacity, typical capital costs are about \$6,000 to \$8,000 per kilowatt (NREL, 2016, p. 15). To address the economic challenges of this segment, the U.S. Department of Energy (DOE) has been investing through the Distributed Wind Competitiveness Improvement Project in technologies with better cost and

EXHIBIT 5-18: Turbine for Distributed Wind Small Turbine Segment

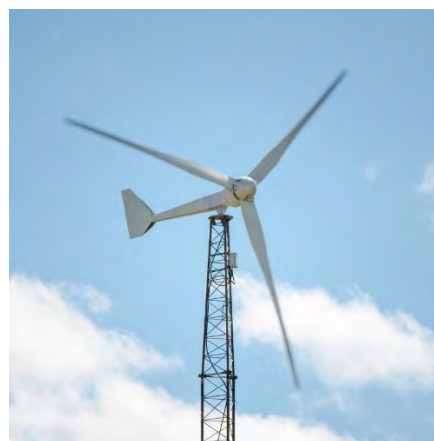

Source: DOE, 2017.

²¹⁰ Capacity factor (CF) is the most common way to gauge annual wind energy system performance. Large turbine distributed wind systems have average CFs of 31 percent, compared to 25 percent for mid-sized turbine systems and 17 percent for small turbine systems (DOE, 2019b, p. 23).

performance characteristics (DOE, 2019g). An example 15-kW turbine supported by that DOE program is shown in *exhibit 5-18*.

CHALLENGES TO EXTENDING ADOPTION

Utility-scale and distributed wind energy systems are expected to continue increasing in size and number within the U.S. electricity sector over the next few years, at least until new systems stop being eligible for the Federal PTC. However, there are several challenges to continuing the industry's rapid growth beyond that time.

Unless extended legislatively, the expiration of the PTC as an incentive for new wind energy systems will effectively occur approximately in 2024 after all systems meeting earlier safe harbor or construction commencement eligibility requirements have been built. Based on historical precedent in the wind energy industry, project deployment drops sharply just after a Federal incentive expires (Minneapolis Fed, 2016; DOE, 2015). Significant improvements in technology performance that have occurred recently and similar enhancements in the future may offset much of the decline in Federal incentives, although two additional adoption challenges may persist.

As the share of wind energy in a given regional transmission grid's electricity mix increases, so does the complexity in managing the variability in wind energy output. Because the amount of electricity produced varies with wind conditions, there may not be sufficient regional transmission capacity to move the power from where it is produced to where it will be consumed. This variability also can make balancing electricity loads on a region's transmission grid challenging, especially for traditional methods of balancing which involve throttling natural gas- or oil-fueled power plants up and down (DOE, 2019e, p. 45). These conditions can cause "curtailments" of wind energy generation for technical or economic reasons (DOE, 2019e, pp. 45–46).²¹¹ In 2018, 2.2 percent of potential electricity generation from wind was curtailed across the seven main independent system operator transmission markets in the United States (DOE, 2019e, p. 46). These issues are similar to those faced by solar power projects (see chapter 4) and have similar solutions. One common solution is to pair wind power with battery storage and/or another generation source to quickly ramp up and down to modulate frequency and provide load balancing services. Because the times of highest wind production are often uncorrelated or negatively correlated with times of highest solar production, generation combinations may ease transmission impacts. Nonetheless, the technical issues associated with variable electricity integration may slow the adoption of new wind energy systems and result in increasing curtailment of electricity production from existing wind systems.

Finally, due to the substantial land lease, grid infrastructure, crane height, and equipment transportation requirements for wind energy systems and their associated biologic, environmental, visual, sound, and economic impacts, there are complexities in securing the necessary leases, permits, and other approvals. As turbine blade lengths and tower heights continue to grow to improve system performance, these complexities may slow wind energy development and increase system costs.

²¹¹ Curtailments involve reducing the delivery of electricity from the wind system to the grid. They can be required by the grid operator for technical reasons to maintain reliable and safe grid operations or can be done by the wind system owner for economic reasons, such as when wholesale electricity prices are negative (DOE, 2019e, p. 45). For a more detailed review of wind and solar energy system curtailment, see NREL, 2014.

REFERENCES

- AWEA. 2020a. *U.S. Wind Industry Quarterly Market Report: Fourth Quarter 2019*. American Wind Energy Association. <https://www.awea.org/resources/publications-and-reports/market-reports/2019-u-s-wind-industry-market-reports> [accessed March 2020]. Note: AWEA merged into the American Clean Power Association (ACP) on January 1, 2021.
- AWEA. 2020b. *Free Use Wind Energy Image Gallery*. American Wind Energy Association. <https://www.awea.org/resources/free-use-wind-energy-image-gallery> [accessed June 2020]. Note: AWEA merged into the American Clean Power Association (ACP) on January 1, 2021.
- Brown, et al. 2012. *Ex Post Analysis of Economic Impacts From Wind Power Development in U.S. Counties*. Brown, Jason, John Pender, Ryan Wisler, Eric Lantz, and Ben Hoen. *Energy Economics*, Volume 34, Issue 6, as pre-printed: <https://eta-publications.lbl.gov/sites/default/files/lbnl-5793e.pdf> [accessed March 2020].
- CRS. 2018. *The Renewable Electricity Production Tax Credit: In Brief*. Congressional Research Service. <https://fas.org/sgp/crs/misc/R43453.pdf> [accessed March 2020].
- DOE. 2015. *Wind Vision: A New Era for Wind Power in the United States*. U.S. Department of Energy. https://www.energy.gov/sites/prod/files/WindVision_Report_final.pdf [accessed March 2020].
- DOE. 2017. *EERE Success Story—Distributed Wind Competitiveness Improvement Project (CIP) Partner Delivers Next-Generation Wind Turbine for On-Site Power*. U.S. Department of Energy. <https://www.energy.gov/eere/success-stories/articles/eere-success-story-distributed-wind-competitiveness-improvement> [accessed March 2020].
- DOE. 2019a. *Wind Energy's Economic Impacts to Communities*. U.S. Department of Energy. <https://windexchange.energy.gov/projects/economic-impacts> [accessed March 2020].
- DOE. 2019b. *2018 Distributed Wind Market Report*. U.S. Department of Energy. <https://www.energy.gov/sites/prod/files/2019/08/f65/2018%20Distributed%20Wind%20Market%20Report.pdf> [accessed March 2020].
- DOE. 2019c. *2018 Offshore Wind Technologies Market Report*. U.S. Department of Energy. <https://www.energy.gov/sites/prod/files/2019/09/f66/2018%20Offshore%20Wind%20Technologies%20Market%20Report.pdf> [accessed March 2020].
- DOE. 2019d. *The Inside of a Wind Turbine*. U.S. Department of Energy. <https://www.energy.gov/eere/wind/inside-wind-turbine> [accessed March 2020].
- DOE. 2019e. *2018 Wind Technologies Market Report*. U.S. Department of Energy. <https://www.energy.gov/sites/prod/files/2019/08/f65/2018%20Wind%20Technologies%20Market%20Report%20FINAL.pdf> [accessed March 2020].
- DOE. 2019f. *Energy Department Awards \$6.8 Million in Wind Energy Research Projects*. U.S. Department of Energy. <https://www.energy.gov/eere/articles/energy-department-awards-68-million-wind-energy-research-projects> [accessed August 2020].
- DOE. 2019g. *Distributed Wind Competitiveness Improvement Project*. U.S. Department of Energy. https://www.energy.gov/sites/prod/files/2019/02/f60/Distributed%20Wind%20Competitiveness%20Project%20Fact%20Sheet%20FY19_1.pdf [accessed March 2020].
- DOE. 2020. *Missouri 80-Meter Wind Resource Map*. U.S. Department of Energy. <https://windexchange.energy.gov/maps-data/66> [accessed March 2020].
- EI. 2018. *Leading the Way: U.S. Electric Company Investment and Innovation in Energy Storage*. Edison Electric Institute. https://www.eei.org/issuesandpolicy/Energy%20Storage/Energy_Storage_Case_Studies.pdf [accessed March 2020].
- EIA. 2019a. *Electric Power Monthly: Monthly Generation Data by State, Producer Sector and Energy Source: Months Through September 2019*. U.S. Energy Information Administration, DOE. <https://www.eia.gov/electricity/monthly/> [accessed December 2019].
- EIA. 2019b. *Wind Explained: Wind Energy and the Environment*. U.S. Energy Information Administration, DOE. <https://www.eia.gov/energyexplained/wind/wind-energy-and-the-environment.php> [accessed August 2020].
- EIA. 2020a. *Wind Explained: Electricity Generation From Wind*. U.S. Energy Information Administration, DOE. https://www.eia.gov/energyexplained/index.php?page=wind_electricity_generation [accessed March 2020].
- EIA. 2020b. *Cost and Performance Characteristics of New Generating Technologies, Annual Energy Outlook 2020*. U.S. Energy Information Administration, DOE. https://www.eia.gov/outlooks/aeo/assumptions/pdf/table_8.2.pdf [accessed March 2020].
- EIA. 2020c. *Levelized Cost and Levelized Avoided Cost of New Generation Resources in the Annual Energy Outlook 2020*. U.S. Energy Information Administration, DOE. https://www.eia.gov/outlooks/aeo/pdf/electricity_generation.pdf [accessed March 2020].

- EIA. 2020d. Wholesale Electricity and Natural Gas Market Data. U.S. Energy Information Administration, DOE. <https://www.eia.gov/electricity/wholesale/#history> [accessed March 2020].
- EIA. 2020e. Electricity Explained. U.S. Energy Information Administration, DOE. <https://www.eia.gov/energyexplained/electricity/prices-and-factors-affecting-prices.php> [accessed March 2020].
- EIA. 2020f. Wholesale Electricity Prices Were Generally Lower in 2019, Except in Texas. U.S. Energy Information Administration, DOE. <https://www.eia.gov/todayinenergy/detail.php?id=42456> [accessed April 2020].
- EIA. 2020g. Capacity Factors for Utility Scale Generators Not Primarily Using Fossil Fuels, Electric Power Monthly. U.S. Energy Information Administration, DOE. https://www.eia.gov/electricity/monthly/epm_table_grapher.php?t=epmt_6_07_b [accessed March 2020].
- ElectricChoice.com. 2018. Map of Deregulated Energy States & Markets. <https://www.electricchoice.com/map-deregulated-energy-markets/> [accessed March 2020].
- EPA. 2012. *How to Use eGRID for Carbon Footprinting Electricity Purchases in Greenhouse Gas Emission Inventories*. U.S. Environmental Protection Agency. <https://www3.epa.gov/ttnchie1/conference/ei20/session3/adiem.pdf> [accessed March 2020].
- EPA. 2018. Electricity Storage. U.S. Environmental Protection Agency. <https://www.epa.gov/energy/electricity-storage> [accessed August 2020].
- EPA. 2019. *Interconnection: Plugging RE-Powering Sites Into the Electric Grid*. U.S. Environmental Protection Agency. https://www.epa.gov/sites/production/files/2019-10/documents/interconnection_plugging_re_powering_sites_into_the_electric_grid_oct2019_508.pdf [accessed March 2020].
- EPA. 2020a. Green Power Partnership, Renewable Energy Certificates (RECs). U.S. Environmental Protection Agency. <https://www.epa.gov/greenpower/renewable-energy-certificates-recs> [accessed March 2020].
- EPA. 2020b. *eGRID Summary Tables 2018*. U.S. Environmental Protection Agency. https://www.epa.gov/sites/production/files/2020-01/documents/egrid2018_summary_tables.pdf [accessed March 2020].
- EPA. 2020c. Greenhouse Gas Equivalencies Calculator (last updated March 2020). U.S. Environmental Protection Agency. <https://www.epa.gov/energy/greenhouse-gas-equivalencies-calculator> [accessed March 2020].
- HelioScope. 2020. Ground-Mount Design 101. <https://help.helioscope.com/article/43-ground-mount-design-101> [accessed March 2020].
- Hoste, et al. 2011. *Matching Hourly and Peak Demand by Combining Different Renewable Energy Sources: A Case Study for California in 2020*. Hoste, Graeme R. G., Michael J. Dvorak, and Mark Z. Jacobson, Stanford University. <https://web.stanford.edu/group/efmh/jacobson/Articles/I/CombiningRenew/HosteFinalDraft> [accessed March 2020].
- HR 1865. 2019. *Further Consolidated Appropriations Act, 2020* (became Public Law 116-94 on December 20, 2019). U.S. House of Representatives Bill 1865. <https://www.congress.gov/bill/116th-congress/house-bill/1865/text> [accessed March 2020].
- IREC. 2020. Interconnection. Interstate Renewable Energy Council. <https://irecusa.org/regulatory-reform/interconnection/> [accessed March 2020].
- IRS. 2019. *Instructions for Form 8835: Renewable Electricity, Refined Coal, and Indian Coal Production Credit*. Internal Revenue Service. <https://www.irs.gov/pub/irs-pdf/i8835.pdf> [accessed March 2020].
- Kansas City Fed. 2013. *Rural Wealth Creation and Emerging Energy Industries: Lease and Royalty Payments to Farm Households and Businesses*. Federal Reserve Bank of Kansas City. <https://www.kansascityfed.org/publicat/reswkpap/pdf/rwp13-07.pdf> [accessed March 2020].
- Lazard. 2019. *Lazard's Levelized Cost of Energy Analysis—Version 13.0*. <https://www.lazard.com/media/451086/lazards-levelized-cost-of-energy-version-13-0-vf.pdf> [accessed March 2020].
- LBNL. 2013. *A Spatial Hedonic Analysis of the Effects of Wind Energy Facilities on Surrounding Property Values in the United States*. Ernest Orlando Lawrence Berkeley National Laboratory. <https://emp.lbl.gov/sites/all/files/lbnl-6362e.pdf> [accessed March 2020].
- LBNL. 2019. *Impact of Wind, Solar, and Other Factors on Wholesale Power Prices*. Ernest Orlando Lawrence Berkeley National Laboratory. https://eta-publications.lbl.gov/sites/default/files/lbnl_-_wind_and_solar_impacts_on_wholesale_prices_approved.pdf [accessed March 2020].
- Minneapolis Fed. 2016. A Time of Testing. Federal Reserve Bank of Minneapolis. <https://www.minneapolisfed.org/publications/fedgazette/a-time-of-testing> [accessed March 2020].
- Mitchell Republic. 2018. Up and Almost Running: Brule County Wind Project Nearly Complete. <https://www.mitchellrepublic.com/business/energy-and-mining/4472354-and-almost-running-brule-county-wind-project-nearly-complete> [accessed March 2020].

- NASEO. 2020. *The 2020 U.S. Energy and Employment Report*. National Association of State Energy Officials and Energy Futures Initiative. <https://static1.squarespace.com/static/5a98cf80ec4eb7c5cd928c61/t/5ee78423c6fcc20e01b83896/1592230956175/USEER+2020+0615.pdf> [accessed June 2020].
- NCCETC. 2014. Solar and Wind Permitting Laws. NC Clean Energy Technology Center. <https://programs.dsireusa.org/system/program/detail/3929> [accessed May 2020].
- NCCETC. 2015a. Wind Permitting Standards. NC Clean Energy Technology Center. <https://programs.dsireusa.org/system/program/detail/5501> [accessed May 2020].
- NCCETC. 2015b. Solar and Wind Energy Business Franchise Tax Exemption. NC Clean Energy Technology Center. <https://programs.dsireusa.org/system/program/detail/82> [accessed May 2020].
- NCCETC. 2015c. Tax Exemption for Wind Energy Generation. NC Clean Energy Technology Center. <https://programs.dsireusa.org/system/program/detail/104> [accessed May 2020].
- NCCETC. 2018. Modified Accelerated Cost-Recovery System (MACRS). NC Clean Energy Technology Center. <https://programs.dsireusa.org/system/program/detail/676> [accessed March 2020].
- NCCETC. 2019. Renewable Portfolio Standards and Clean Energy Standards, Detailed Summary Maps, DSIRE®. NC Clean Energy Technology Center. <http://www.dsireusa.org/resources/detailed-summary-maps/> [accessed March 2020].
- NCCETC. 2020. DSIRE®. NC Clean Energy Technology Center. <https://www.dsireusa.org/> [accessed March 2020].
- NREL. 2007. *Distributed Wind Market Applications*. National Renewable Energy Laboratory. <https://www.nrel.gov/docs/fy08osti/39851.pdf> [accessed April 2020].
- NREL. 2009. *Land-Use Requirements of Modern Wind Power Plants in the United States*. National Renewable Energy Laboratory. <https://www.nrel.gov/docs/fy09osti/45834.pdf> [accessed March 2020].
- NREL. 2011. *A Review of Operational Water Consumption and Withdrawal Factors for Electricity Generating Technologies*. National Renewable Energy Laboratory. <https://www.nrel.gov/docs/fy11osti/50900.pdf> [accessed August 2020].
- NREL. 2013. *United States—Land-Based and Offshore Annual Average Wind Speed at 100 m*. National Renewable Energy Laboratory with AWS Truepower. https://www.energy.gov/sites/prod/files/2013/12/f5/wind_speed_map_hi-res.pdf [accessed March 2020].
- NREL. 2014. *Wind and Solar Energy Curtailment: Experience and Practices in the United States*. National Renewable Energy Laboratory. <https://www.nrel.gov/docs/fy14osti/60983.pdf> [accessed March 2020].
- NREL. 2016. *Assessing the Future of Distributed Wind: Opportunities for Behind-the-Meter Projects*. National Renewable Energy Laboratory. <https://www.nrel.gov/docs/fy17osti/67337.pdf> [accessed March 2020].
- NREL. 2020. *Land Use by System Technology*. National Renewable Energy Laboratory. <https://www.nrel.gov/analysis/tech-size.html> [accessed March 2020].
- NYSERDA. 2017. *New York Wind Energy Guide for Local Decision Makers: Land Agreements*. New York State Energy Research and Development Authority. <https://www.nyserda.ny.gov/All-Programs/Programs/Clean-Energy-Siting/Wind-Guidebook> [accessed March 2020].
- Sandia. 2012. *Vertical-Axis Wind Turbines Revisited: A Sandia Perspective*. Sandia National Laboratories. <https://energy.sandia.gov/wp-content/gallery/uploads/3-B-1-Barone-SAND2012-5503C.pdf> [accessed March 2020].
- Shultz, et al. 2015. *Production of Wind Energy and Agricultural Land Values: Evidence From Pennsylvania*. Shultz, Chris, Joshua C. Hall, and Michael P. Strager, West Virginia University. <https://ideas.repec.org/p/wvu/wpaper/15-11.html> [accessed March 2020].
- U.S. Department of State. 2017. *Energy in One Texas City: Good Planning Makes Good Business*. <https://share.america.gov/texas-town-transitions-to-renewable-energy/> [accessed March 2020].
- USDA. 2017. *Wind Energy Land Distribution in the United States of America*. U.S. Department of Agriculture. https://www.usda.gov/oce/energy/files/FINAL-Wind_Energy_Land_Distribution_in_the_United_States_of_America_7282017.pdf [accessed March 2020].
- USDA. 2019. *2017 Census of Agriculture: United States Summary and State Data, Volume 1, Geographic Area Series, Part 51*. U.S. Department of Agriculture. https://www.nass.usda.gov/Publications/AgCensus/2017/Full_Report/Volume_1,_Chapter_1_US/usv1.pdf [accessed March 2020].
- USDA. 2020. *Rural Energy for America Program Renewable Energy Systems & Energy Efficiency Improvement Guaranteed Loans & Grants*. U.S. Department of Agriculture. <https://www.rd.usda.gov/programs-services/rural-energy-america-program-renewable-energy-systems-energy-efficiency> [accessed March 2020].

USFWS. 2018. Wind Turbines. U.S. Fish and Wildlife Service. <https://www.fws.gov/birds/bird-enthusiasts/threats-to-birds/collisions/wind-turbines.php> [accessed August 2020].

USGS. 2011. *Wind Energy in the United States and Materials Required for the Land-Based Wind Turbine Industry From 2010 Through 2030*. U.S. Geological Survey, U.S. Department of the Interior. <https://pubs.usgs.gov/sir/2011/5036/sir2011-5036.pdf> [accessed March 2020].

Windustry. 2020. FAQ: How Much Do Farmers Get Paid to Host Wind Turbines? http://www.windustry.org/how_much_do_farmers_get_paid_to_host_wind_turbines [accessed March 2020].

Xcel Energy. 2017. *2016 Electric Resource Plan, 2017 All Source Selection 30-Day Report (Public Version)*. Public Service Company of Colorado (dba Xcel Energy). https://cdn.arstechnica.net/wp-content/uploads/2018/01/Proceeding-No.-16A-0396E_PUBLIC-30-Day-Report_FINAL_CORRECTED-REDACTION.pdf

6. CORN ETHANOL REFINERIES

INTRODUCTION

Production of corn ethanol in the United States has increased almost ten-fold over the past 20 years, reaching more than 16 billion gallons in 2018 (USDA, 2019a, p. table 10 and table 16). Policies such as subsidies, tax incentives, and regulations have been a main driver in bringing the industry to its current state of maturity. **Starting in 2010, 10 percent ethanol gas (called “E10”) has been sold in all 50 States** in order to boost octane, meet air quality requirements, or satisfy the Renewable Fuel Standard set forth in the Energy Independence and Security Act of 2007 (EIA, 2019a; EIA, 2019b). Recent research by the U.S. Department of Agriculture (USDA) and ICF found that life cycle greenhouse gas (GHG) emissions from corn ethanol are almost 40 percent less than gasoline currently, and are projected to be 44 percent less than gasoline by 2022 (Rosenfeld, et al., 2018, p. 98).

Six key takeaways about U.S. corn ethanol production are the following:

1. In 2018, almost 40 percent of corn grown in the United States was used for ethanol production (DOE, 2019a).
2. Corn production has been able to keep up with demand, and the USDA Economic Research Service (ERS) estimates that U.S. corn production should be adequate to supply all needs, including ethanol feedstocks, through 2028.
3. The major corn production area and the majority of ethanol biorefineries are concentrated in the Midwest, representing more than 90 percent of domestic ethanol production in 2018 (EIA, 2019c).
4. Between 2010 and 2019, process and operational efficiencies implemented throughout the ethanol industry (including new co-products, new strains of yeast, efficient energy systems, and more), increased average ethanol production yields (gallons per bushel of corn) by 7 percent and decreased production-related energy usage (British thermal units per gallon [Btus/gal]) by 11 percent (Christianson CPAs & Consultants, 2020).
5. Domestic production ethanol increased from 1.6 billion gallons in 2000 to 16 billion gallons in 2018 (EIA, 2019a, table 10.3). Ethanol fuel exports have steadily increased from 400 million gallons in 2010 to almost 1.4 billion gallons in 2017 (EIA, 2018a).
6. Corn ethanol production has plateaued in recent years. Further growth will depend on several factors, including increasing consumer acceptance of ethanol blends above E10, addressing technical issues and infrastructural barriers currently limiting wider distribution and retail sale of these higher blends, and expanding export markets.

These takeaways are explored in greater depth in the remainder of this chapter, which includes the following sections:

- An overview of corn feedstock production
- A technical characterization of the ethanol refining process
- An overview of the current state of adoption and regional considerations
- A summary of adoption costs
- Highlights of the potential economic, environmental, and land use impacts of adopting corn ethanol
- A discussion of the dominant ownership and financing model
- Highlights of key policy drivers that have facilitated corn ethanol adoption
- An outlook on the challenges that the ethanol industry faces to continued growth

CORN FEEDSTOCK CHARACTERIZATION

Corn is the dominant grain produced in the United States and comprises approximately 30 percent of all domestic planted acres (USDA, 2019b, pp. 106 -107). In the United States, corn is primarily used for

animal feed, food, seed, and industrial purposes (including fuels). Since the early 1980s, the percent of domestic corn used for ethanol production has increased from almost none to nearly 40 percent in 2018 (USDA, 2018a). In 2018, the United States was the largest global producer of ethanol, accounting for 56 percent of world production—which was double the volume produced by the second largest producer, Brazil (RFA, 2019a, p. 6).

The increased demand for corn related to higher ethanol production levels has been met through increasing corn yields, adjusting corn-soybean rotations in favor of more corn, shifting additional agricultural land into corn production (such as from other crops, pasture, and fallow), and bringing new land into agricultural production. While corn acreage has increased slowly over the past 20 years, from approximately 80 million acres in 1999 (USDA, 1999, p. 18) to around 92 million acres in 2019 (USDA, 2019c, p. 10), corn yields have also increased significantly from about 134.4 bushels/acre in 1998 to almost 170 bushels/acre today (or about 2 bushels/acre per year) (USDA, 2018b; USDA, 2020a). Corn production has grown from 9.4 billion bushels in 1999 to 14.4 billion bushels in 2018 (USDA, 2019d). United States corn production is currently projected to meet demand for all uses, including ethanol, through 2028 (USDA, 2019e).

TECHNOLOGY CHARACTERIZATION

Corn ethanol refining primarily employs two production processes—dry milling and wet milling. Approximately 90 percent of ethanol production facilities are categorized as dry mill, owing to their lower capital and operational costs compared with wet mill (DOE, 2018, p. 2). Due to the similarities in dry and wet mill ethanol production, much of this section's production process description is in the dry mill sub-section and is not repeated in the wet mill sub-section. This section discusses ethanol process improvements, including corn oil recovery and combined heat and power.

Dry Mill

Dry mill plant ethanol production begins by crushing, or milling, the whole grain kernels, creating what is known as “meal.” The meal is combined with water and alpha-amylase enzyme to form a “mash” or “slurry,” which is then heated; this step is referred to as “liquefaction” and it is designed to reduce the viscosity of the slurry and initiate the break-down of the long starch molecules into smaller ones. There are three liquefaction processing options, all of which entail the addition of amylase, which breaks down starch molecules, and a heating input. After liquefaction, the mash is cooled.

To further break down the starch molecules, known as saccharification, gluco-amylase enzyme is added to the cooled mash as it is transferred to fermenters, where yeast (*saccharomyces cerevisiae*) is added for simultaneous saccharification and fermentation. The yeast metabolizes the sugars present in the mash and produces ethanol and carbon dioxide (CO₂). Most fermenters are operated on a 40-hour batch cycle, and the mixture of ethanol, water, and residual solids at the end of fermentation is known as beer. The beer is then passed through a distillation column where the ethanol and some water are distilled, leaving a mixture of water and corn solids called “whole stillage.”

The whole stillage is passed through a centrifuge to remove the large suspended solids in the form of wet distillers grain (WDG). The dissolved solids and small suspended solids that pass through the centrifuge are known as “thin stillage”. Thin stillage is converted to condensed solubles (syrup) through an evaporation process. Inedible corn oil is extracted during the evaporation process; this inedible corn oil is typically used for biodiesel production (RFA, 2019a, p. 7). The WDG and syrup are combined to form wet distillers grains with solubles (WDGS), which is sold locally or used on-site for livestock feed. Ethanol facilities that cannot use WDGS on-site or locally pass the WDGS through rotary dryers to produce dried distillers grains with solubles (DDGS). DDGS can be transported using normal grain-handling railcars. The complete dry mill process is illustrated in *exhibit 6-1*.

EXHIBIT 6-1: Dry Milling Process

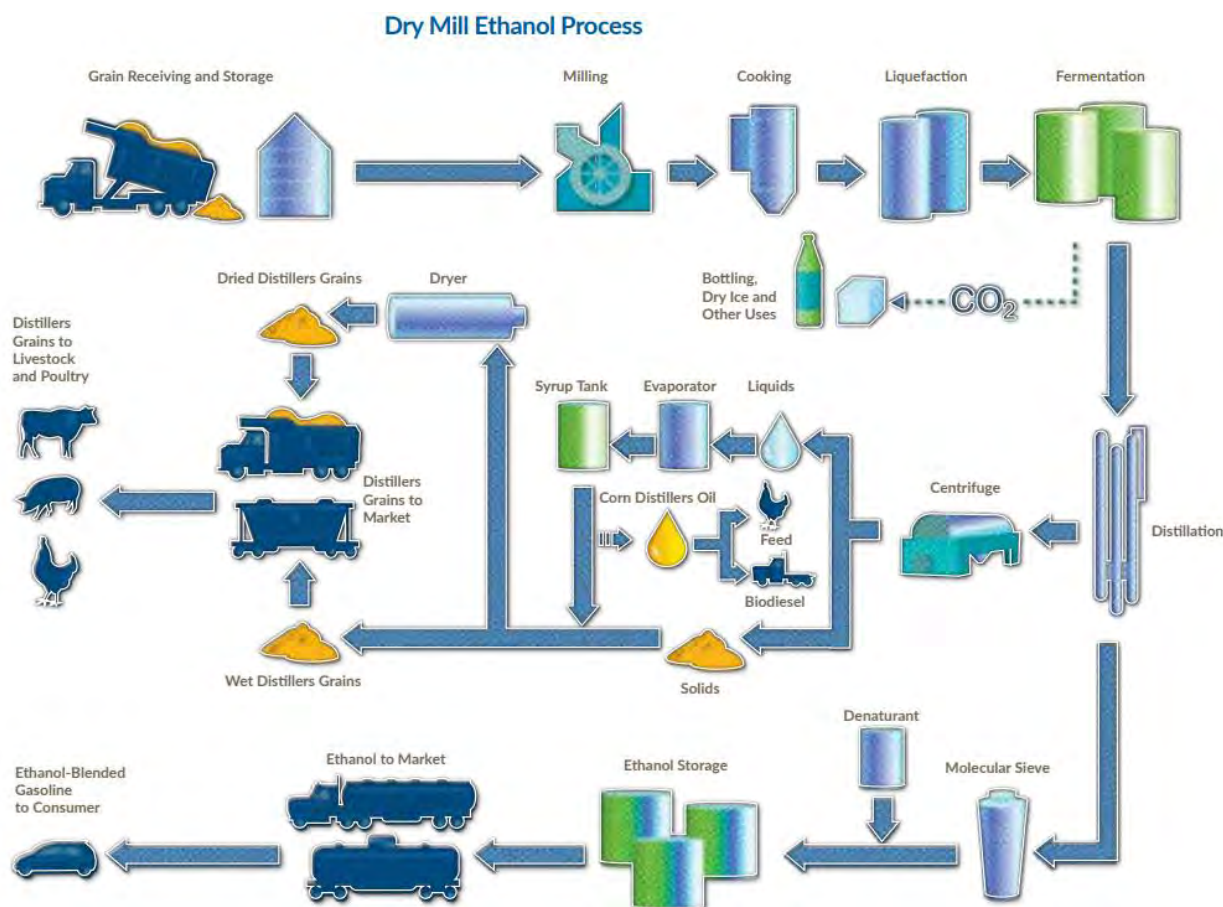

Source: RFA, 2019a, p. 21.

Wet Mill

The wet mill process begins by soaking whole kernels in a heated sulfurous acid solution for 2 days; this step breaks down the kernel into starch, fiber, corn germ, and protein. The starch is then processed to produce ethanol in a similar manner as dry mill ethanol production (Clifford, 2018). The remaining components are then processed into the co-products including gluten meal and gluten feed (used for animal feed and other products) and corn oil (not for human consumption) (Clifford, 2018). *Exhibit 6-2* illustrates the different end-product pathways for a typical wet mill ethanol.

EXHIBIT 6-2: Wet Milling Process

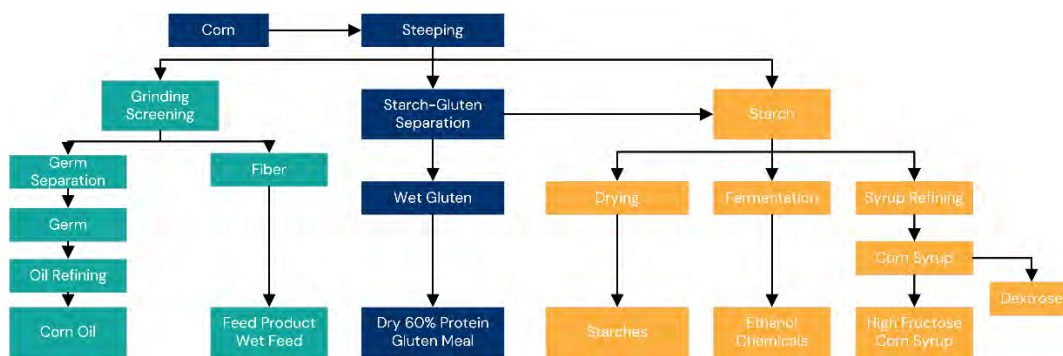

Source: ICF, based on Clifford, 2018.

Process Efficiencies

Since the corn ethanol industry's inception, there has been a determined effort to improve refining efficiencies. These efficiency efforts have focused on lowering costs by increasing ethanol yields, reducing natural gas consumption, and eliminating process water discharge.

An illustrative example of the industry's emphasis on efficiency is to compare ethanol yields per bushel of corn in 1997 and 2014. If the average ethanol yield in 2014 was the same as it was in 1997, approximately 343 million *additional* bushels of corn, or 7 percent more corn, would have been required to produce the same quantity of fuel (EIA, 2015). Incremental improvements to the efficiency of ethanol production, as shown in *exhibit 6-3*, have been significant in the development and competitiveness of this biofuel.

Process efficiency improvements in corn ethanol production have been achieved through a combination of:

- Energy integration improvements to reduce process energy requirements
- The achievement of zero process water discharge where organic material that previously was discharged is converted to methane and combusted within the dryers (ICM, 2009)
- Enhancements to the enzymes and yeast (EIA, 2015)
- The removal of corn oil, which reduces fouling²¹² in the evaporators (xpirt agriculture, 2019)
- The development of the WDGS market that gives ethanol producers options for not drying their distillers grains to DDGS.

These improvements have reduced the energy required to produce a gallon of ethanol from 53,956 Btu/gal of ethanol in 1995 to approximately 19,000 Btu/gal when producing WDGS or 28,000 Btu/gal when producing DDGS (Christianson CPAs & Consultants, 2020; ILSR, 1995, p. 5). The Energy Information Administration (EIA) has estimated the denatured ethanol production has increased from approximately 2.5 gallons/bushel of corn in 1982 to approximately 2.8

gallons/bushel in 2014 (EIA, 2015). Corn oil recovery systems were introduced around 2012, and the technology had been deployed to most ethanol refineries by 2017. In 2018, membrane separation units were introduced into the market to replace the molecular sieve dehydration units (Albrecht, 2018).

Adding hydrolytic enzymes that improve fermentation performance is another approach that increases oil recovery by increasing ethanol yield (Luangthongkam et al., 2015). Implementation of technologies to increase cellulosic ethanol from corn kernel fiber have been successful and adopted by a few refineries but are not yet in widespread use (U.S. Grains Council, 2018). The process to convert corn kernel fiber into cellulosic ethanol is discussed further in the Current State of Adoption and Regional Distinctions section. According to the Renewable Fuels Association (RFA), if existing ethanol plants were to process corn fiber, it would increase ethanol production by hundreds of millions of gallons (RFA, 2019a, p. 22).

EXHIBIT 6-3: Improvements in Corn Ethanol Utilization and Yield

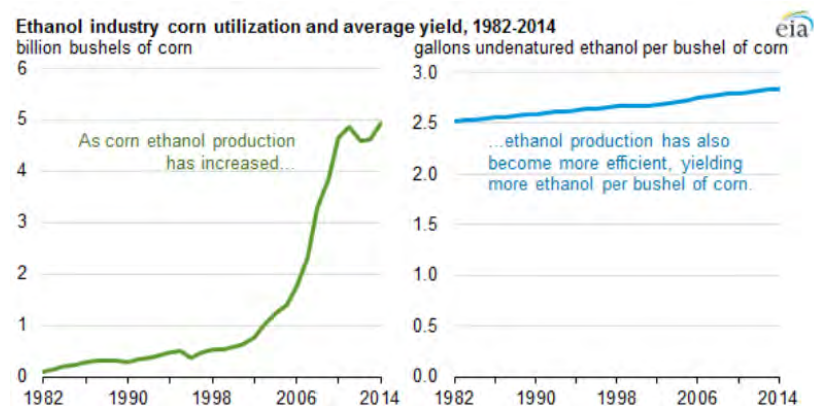

Source: EIA, 2015.

²¹² Fouling is the formation of unwanted growth or deposits on surfaces, which can cause operational malfunctions.

Combined Heat and Power

Combined heat and power (CHP), also referred to as “co-generation,” is a technological innovation that utilizes one energy input to produce two or more usable energy outputs (in this case, process heat and electric power). Ethanol facilities could significantly improve facility-wide energy efficiency with a CHP system that utilizes feedstock waste (i.e., corn stover) as a fuel source (Morey, 2011).

CHP configurations for ethanol production typically utilize natural gas or corn stover from agricultural waste. In corn stover combustion, steam is produced in a biomass boiler and electricity is produced using a backpressure turbine (*exhibit 6-4.a*). A similar process is used for CHP with syrup and corn stover combustion, except that the syrup is not dried and instead is combusted along with the corn stover in a fluidized bed boiler (*exhibit 6-4.b*).

EXHIBIT 6-4: Two Ethanol Plant CHP Configurations

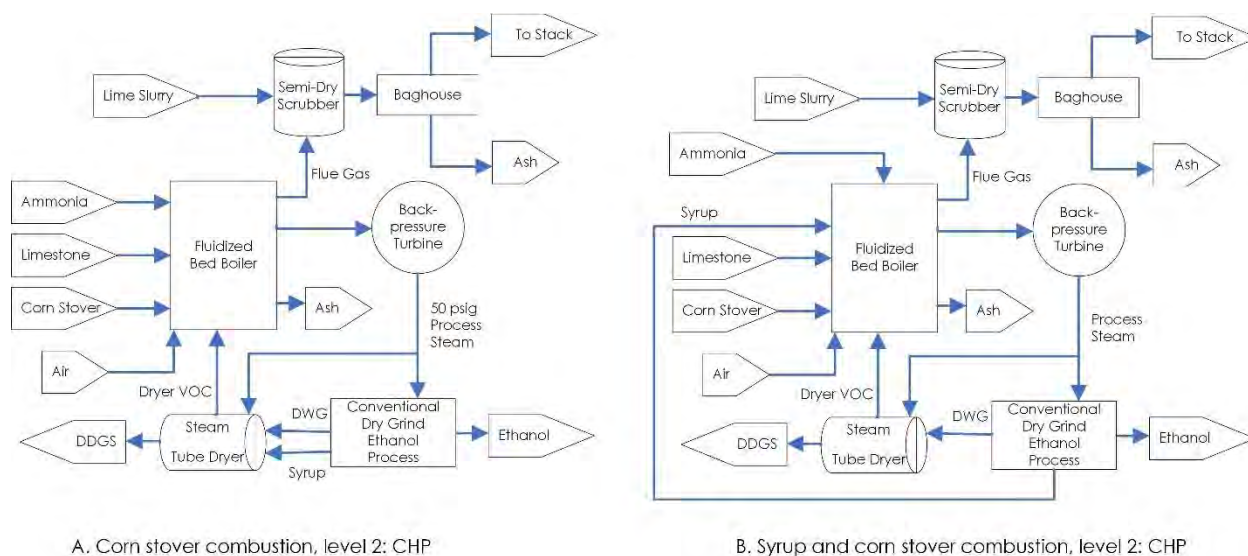

Source: ICF, based on De Kam et al., 2009.

CURRENT STATE OF ADOPTION AND REGIONAL DISTINCTIONS

Production of biofuel ethanol in the United States comes almost entirely from corn. In 2018, the United States produced more than 16 billion gallons of corn ethanol and consumed just under 16 billion gallons (USDA, 2019a, table 10 & 16). *Exhibit 6-5* shows U.S. production increasing over time from 1.6 billion gallons in 2000 to 16 billion gallons in 2018.

While production has increased by almost a factor of ten during the past two decades, recent EIA reports have projected ethanol production to stabilize through 2030 (noted as “other” in *exhibit 6-6*). Ethanol’s share of total transportation fuel supply has been relatively constant at about 10 percent for the past several years and fuel consumption has leveled out (EIA, 2019b; EIA, 2019d). This is due to two

EXHIBIT 6-5: U.S. Corn Ethanol Production from 2000-2018 in Billion Gallons

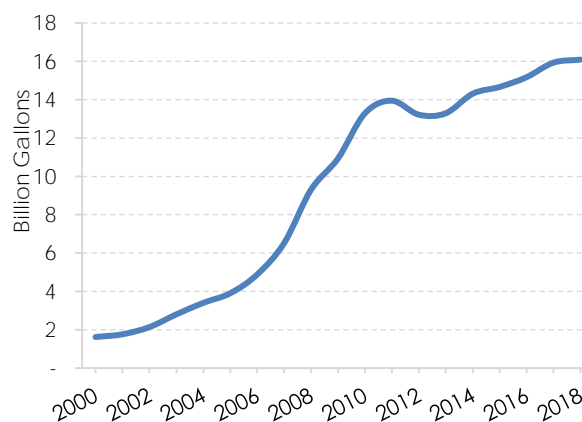

Source: USDA, 2019a, table 10 & 16.

factors: (1) the 15-billion-gallon limit for ethanol produced from corn kernel starch within the United States Renewable Fuel Standard (RFS),²¹³ and (2) the ethanol blending limit of 10 percent due to Reid vapor pressure (RVP) limitations for gasoline sold during the summer months. The U.S. Environmental Protection Agency (EPA) recently extended the RVP waiver such that 15 percent ethanol blends can be sold year-round in the United States lifting the E10 blend limit (Pamuk et al., 2019). EIA projects that the 10 percent blend will remain stable in the coming decades, while many in the ethanol industry believe that the ethanol market can expand rapidly to 15 percent (EIA, 2019e).

While domestically produced fuel ethanol is primarily consumed in the United States, exports have grown from approximately 50,000 barrels per day in 2014 to an average of 110,000 barrels per day in 2018 (EIA, 2019d). In total, U.S. ethanol exports reached a record 10.6 percent of total U.S. ethanol production in 2018, representing more than one out of every 10 gallons produced (RFA, 2019b). Changes in export values are driven in part by ethanol policies in foreign countries. For example, Brazil has a mandate to increase ethanol's share of transportation fuel consumption to 27 percent, and ethanol feedstock costs (i.e., corn production) are higher in Brazil than in the United States (EIA, 2018a). Similarly, Canada imports U.S. ethanol to meet a blending mandate (EIA, 2018a).

Since 2014, imports have been under 100 million barrels/year as exports during the same period have been steadily increasing. Exhibit 6-7 and exhibit 6-8 show, respectively, the locations and trends in U.S. fuel ethanol exports since 2010 and U.S. annual fuel ethanol imports since 2008.

EXHIBIT 6-7: U.S. Ethanol Exports by Location and Volume (2010-2017)



Source: EIA, 2018a

EXHIBIT 6-6: Transportation Sector Consumption Projections through 2050

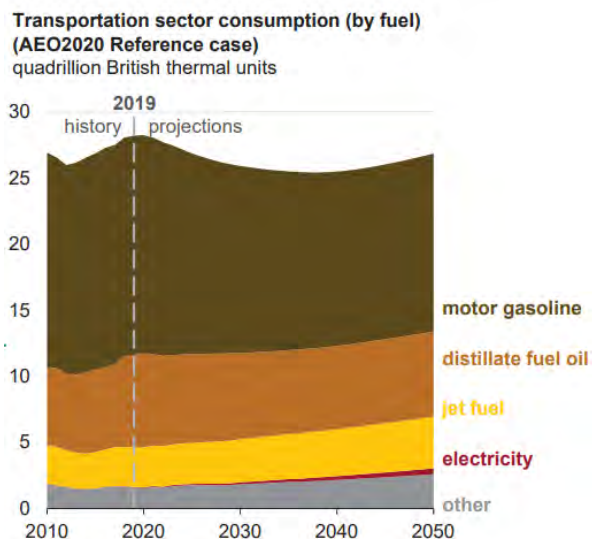

Source: EIA, 2020a, p. 95.

EXHIBIT 6-8: U.S. Fuel Ethanol Imports

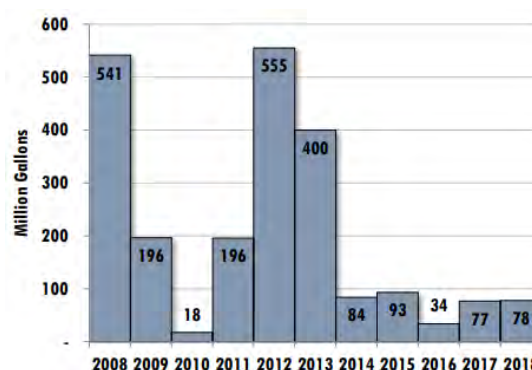

Source: RFA, 2019b, p. 2.

²¹³ The 15-billion-gallon limit on corn ethanol is not a set limit but rather the remaining volume after subtracting the set volume requirements for cellulosic and other advanced biofuels.

Corn ethanol plants are primarily located in the Midwest, in proximity to corn feedstock production. EIA tracks regional ethanol production metrics by Petroleum Administration for Defense Districts (PADDs) (EIA, 2018b). Exhibit 6-9 shows fuel ethanol production capacity over time for the different PADDs. Over the past decade, the Midwest has dominated ethanol production (accounting for more than 90 percent of U.S. production in 2018) and has continued to grow in capacity while other regions have remained relatively stable. As of 2019, there were more than 200 ethanol refineries in the United States and an additional nine under construction or expansion (RFA, 2019a, p. 3).

EXHIBIT 6-9: U.S. Ethanol Production Capacity by PADD Region (2011-2018)

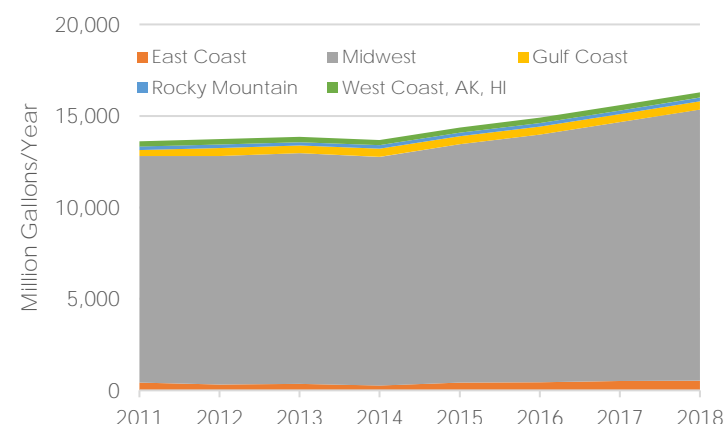

Source: EIA, 2018b.

ADOPTION COSTS

Ethanol profitability varies over the year. The lowest profit margins traditionally occur in the first quarter, while the highest margins are generally obtained in the fourth quarter after the new harvest comes in and prior to the RFS refinery compliance deadlines at the end of the year (ICF Expert Judgment). In order to track the profitability of ethanol production, many researchers use an economic model of a representative Iowa ethanol plant.

The following sections summarize costs obtained from the “Hofstrand model,” an economic model of a representative 100-million gallon per year (MMGPY) capacity ethanol plant constructed in Iowa in 2007, producing ethanol and DDGS (Irwin, 2019; Hofstrand, 2020). Ethanol plants are generally one of two sizes, 50 MMGPY or 100 MMGPY, but can vary across the industry. Operating profit margins at the different sizes tend to be commensurate with one another. The smaller plants generally receive favorable corn pricing without the grain handler’s markup, while larger plants scale their fixed costs over more gallons to take advantage of economies of scale. The following sections provide details on the estimated cost of producing ethanol using assumptions for a representative plant in Iowa and 2018 prices.

The levelized cost of fuel (LCOF) is a metric used to approximate the price at which a fuel would need to be sold to break even (in units of US\$ per gallon of gasoline equivalent). This calculation includes the ethanol plant cost distributed over the lifetime of the plant, the per gallon production costs, and the co-product revenue. Exhibit 6-10 summarizes the LCOF for ethanol plants of 50- and 100- MMGPY production capacities, as well as the component parts of the production costs from the Hofstrand model (Hofstrand, 2020). The costs reflect the average annual production costs in 2020.

EXHIBIT 6-10: Estimated LCOF for Ethanol Production

Production Capacity	\$/gallon of Ethanol						LCOF
	Production Costs					Co-Product Revenue	\$/gallon of Ethanol
	Corn	NG	Plant Costs		Total	DDGS	
Fixed			Other Variables	Total			
MMGPY							
50	1.34	0.14	0.43	0.22	2.13	0.41	1.72
100	1.34	0.14	0.21	0.22	1.91	0.41	1.50

Capital

The Hofstrand model assumes that the construction costs of the representative ethanol plant are greater than \$211 million (Hofstrand, 2020). This value is inclusive of site preparation, engineering expenses, permitting, financing, and construction costs. The model assumes that the project cost is financed through 40 percent debt and 60 percent equity financing (Irwin, 2019).²¹⁴ Absent government loan guarantees or other financial incentives, it appears that new plants are generally financed with 50 percent to 60 percent debt (ICF Expert Judgment).

Operations and Maintenance

Operations and maintenance (O&M) costs for the model ethanol plant include fixed, feedstock inputs, and other (variable and non-fuel) costs.

Fixed and Owners' Expenses

The fixed O&M costs of an ethanol plant include the following:

- Maintenance materials and services
- Direct and indirect labor and benefits
- Operations management
- Office and lab expenses, training, and travel
- Professional consulting fees

In addition to the capital costs, the representative 100-MMGPY ethanol plant has fixed costs of \$0.21/gal of ethanol produced (Hofstrand, 2020). This value is generally consistent between the 50- and 100-MMGPY units because both units require approximately 40 to 45 staff to operate due to automation. Owners' expenses typically include property taxes, insurance, and any corporate indirect expenses attributed to the project (Hofstrand, 2020).

Feedstock and Variable Costs

The representative ethanol plant produces 2.80 gallons of denatured ethanol (including the denaturant) per bushel of corn processed (Hofstrand, 2020). The unit costs of inputs such as corn, natural gas (NG), denaturant, yeast, chemicals, and enzymes are generally consistent regardless of the scale of the facility and are reported on a per gallon of ethanol basis. The cost of corn in the United States averaged \$3.75 per bushel in 2019 (USDA, 2019f), which translates to a wholesale cost of \$1.34/gal of ethanol produced (see *Exhibit 6-10*) (Hofstrand, 2020).

The amount of natural gas necessary to produce a gallon of ethanol is approximately 28,000 Btu/gal when producing DDGS or 19,000 Btu/gal when producing WDGS (Christianson CPAs & Consultants, 2020). Facilities can produce a blend of products or "modified" DDGS, which are an intermediate blend of wet (70 percent water) and dry (11 percent water) DGS. Based on the average price of natural gas in 2019 of \$2.57 per million Btu, the cost of natural gas in the 100-MMGPY ethanol plant in *exhibit 6-10* is \$0.14/gal of ethanol produced (EIA, 2020b).

Other non-fuel or feedstock variable costs include chemicals, enzymes, yeast, denaturant, electricity, water, repairs and maintenance, and transportation. In both size ethanol plants in *exhibit 6-10*, these variable costs are \$0.22/gal of ethanol produced (Hofstrand, 2020).

Producers add a denaturant to fuel ethanol before transportation to forgo the taxes to which beverage ethanol is subject. Denatured ethanol is then transported (typically as E98)²¹⁵ to blending terminals where it is blended with gasoline. This denaturant is typically a natural gas liquid, or natural gasoline,

²¹⁴ The price assumptions in the economic model are consistent with the known cost of construction for other ethanol plants across the country (ICF Expert Judgment).

²¹⁵ Fuel containing 98 percent ethanol and 2 percent gasoline.

which is blended to between 2 percent and 5 percent of the final product volume. Adding the denaturant and displacing a corresponding volume of clear ethanol leads to a small increase in the cost of fuel ethanol (approximately \$0.03/gal) (Hofstrand, 2020).

Co-Products

Ethanol production also results in marketable co-products, such as inedible corn oil, CO₂, WDGS, and DDGS. Corn oil and CO₂ yields from ethanol production typically average 0.80- and 16.5 pounds per bushel of corn processed (RFA, 2019a). Similarly, an average of 16 pounds of DDGS are produced per bushel of corn processed (Irwin, 2019). The Hofstrand model in *exhibit 6-10* estimates a revenue of \$0.41/gal of ethanol generated from DDGS, but does not include corn oil or CO₂ revenues.

ADOPTION IMPACTS

Corn ethanol production has an array of impacts beyond its value as a fuel. This section examines environmental (i.e., GHG emissions and agricultural waste), crop value (i.e., co-products), and energy security impacts.

Corn ethanol, and other biofuels, provide lower-carbon, alternative fuel options for the transportation sector, which makes up 28 percent of total U.S. GHG emissions (EPA, 2019, pp. ES-24). Recent research by USDA and ICF found that life cycle GHG emissions from corn ethanol are almost 40 percent less than gasoline currently, and are projected to be 44 percent less than gasoline by 2022 (see BAU scenario in *exhibit 6-11*) (Rosenfeld, et al., 2018). The researchers also generated a high efficiency-high conservation (HEHC) scenario where farmers and refineries could further reduce emissions by utilizing low-emission practices in feedstock production (e.g., reduced tillage, cover crops, and various nitrogen management practices) and by using renewable biomass instead of fossil fuels as the refinery process fuel. Employing these practices at a dry mill refinery and on the farms providing feedstock corn to that refinery could result in corn ethanol lifecycle emissions over 70 percent below the emissions of an energy-equivalent quantity of gasoline (Rosenfeld, et al., 2018). *Exhibit 6-11* shows the study results for how each life cycle stage contributes to the overall emissions of corn ethanol for different production scenarios compared with those of gasoline.

Several studies analyzed the land use changes associated with the increases in corn ethanol production that occurred between 2004 and 2012 (Wright & Wimberly, 2013; Lark, Salmon, & Gibbs, 2015; Morefield, LeDuc, Clark, & Iovanna, 2016; Motamed, McPhail, & Williams, 2016; Wright, Larson, Lark, & Gibbs, 2017). These studies found that the increased production of corn for ethanol over this period resulted in millions of acres of existing cropland shifting into corn and out of other crops and that millions of acres in other uses (mainly pasture and other managed grasslands, idled cropland, and some forests and natural grasslands) shifted into managed cropland (for corn and other crops). The increases in land use for corn production were concentrated in areas within 100 miles of an ethanol refinery. This meant that the increase in cropland often reflected infilling of commodity production in already cropland-intense regions. In general, conversions of grasslands, forests, and natural ecosystems to croplands results in decreases in soil quality, wildlife habitat, and wildlife populations (EPA, 2018; EIA, 2019f).

Producing corn for ethanol can also have negative impacts on water quality and quantity. Depending on local and regional circumstances, these can include higher levels of erosion, chemical loadings to surface and ground waters, eutrophication, and increased water withdrawals for irrigation from stressed aquifers and surface waters (EPA, 2018).²¹⁶ While annual corn ethanol production has stabilized between 15 and 16 billion gallons in recent years, impacts similar to those discussed above could be

²¹⁶ Eutrophication is the process by which excessive levels of nutrients enter a body of water and stimulate algae growth. The algae growth eventually depletes oxygen levels and blocks sunlight leading to damaged aquatic ecosystems. For more information, see USGS, 2020.

expected if production ramps up significantly in the future (e.g., to meet higher export demands or increased domestic demand for higher ethanol blends such as E15).

The animal feed co-products of corn ethanol production (WDGS and DDGS from dry milling, and, corn gluten meal/feed from wet milling) replace conventional animal feed, and so reduce the crop production requirements needed for feed crops (Arora et al., 2008, p. 1). In 2018, the U.S. corn ethanol industry produced more than 37 million metric tons of DDGS, and exported more than 12 million metric tons to countries including Mexico, South Korea, Vietnam, and Thailand (RFA, 2019a, p. 9). Corn oil can also be recovered from dry milling processes, which can be used as a biodiesel feedstock or for animal feed. EIA reported that more than 2 billion pounds of corn oil were used for biodiesel production in 2018 (EIA, 2020c). In addition, ethanol production produces carbon dioxide as a byproduct; one bushel of corn, on average, produces 16.5 pounds of CO₂ (RFA, 2020a). Ethanol plants sell captured CO₂ primarily to the beverage industry for carbonation and the meat industry for refrigeration.

Ethanol producers can also utilize corn stover, or the fibers from the corn kernel, in the production of cellulosic ethanol. While more than 95 percent of fuel ethanol is produced from corn grains (Davis, 2018), corn stover provides additional value to some ethanol producers while reducing waste. POET-DSM's Liberty corn stover-to-ethanol plant in Emmetsburg is the first large-scale (25-MMGPY) corn stover cellulosic plant to be installed in the United States (DOE, n.d.-a). Ace Ethanol in Stanley, WI, is installing the D3Max corn kernel fiber to cellulosic ethanol bolt-on technology; as of the publication of this report, the unit is in the start-up phase and is not yet in production (BBI International, 2019). Corn stover can also be used to produce heat for ethanol refineries, providing a local renewable energy source (Wang et al., 2014, p. 9).

The corn ethanol industry can have significant economic impacts for rural communities in America. The Renewable Fuels Association reported that there were 68,684 direct jobs, 280,327 indirect and induced jobs, and \$23.3 billion in generated household income associated with the ethanol industry in 2019 (RFA, 2020b).

EXHIBIT 6-11: Life Cycle GHG Emissions of Corn Ethanol and Gasoline

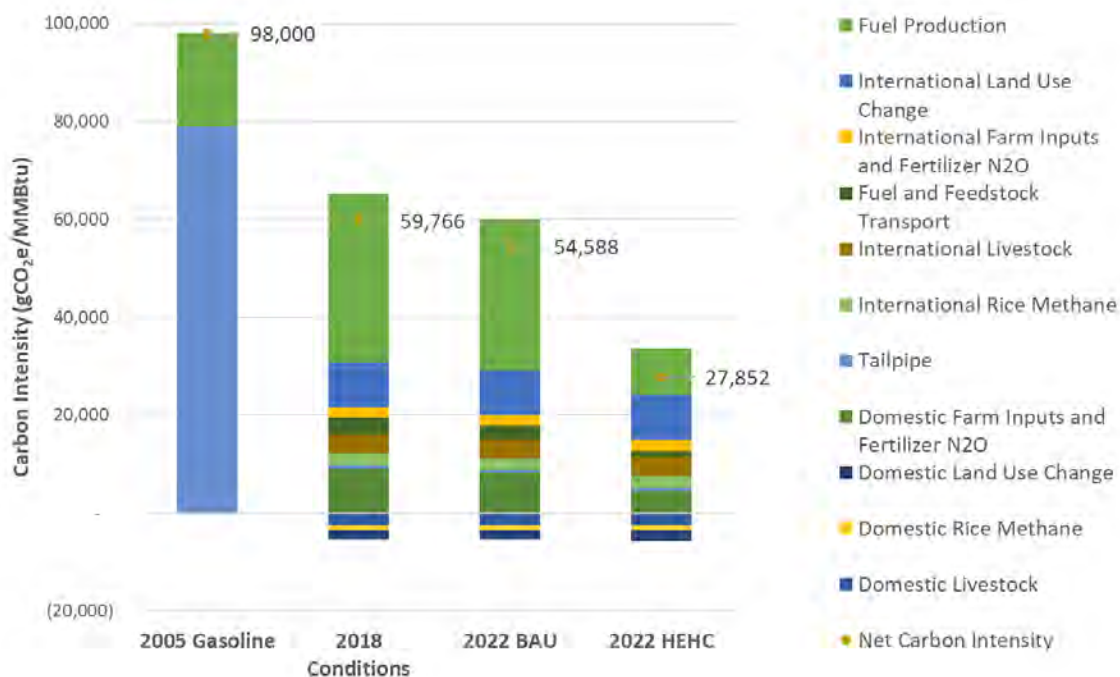

HEHC denotes the high efficiency-high conservation scenario and BAU reflects business-as-usual.

Source: Rosenfeld, et al., 2018.

Because ethanol is blended in petroleum products, corn ethanol provides energy security to national, State, and local governments by reducing the need for petroleum imports (DOE, 2019c). In 2018, RFA estimated that nearly 600 million barrels of imported oil would have been needed without ethanol's contribution of 16 billion gallons of ethanol produced (RFA, 2019a, p. 24). If blend rates increase beyond 10 percent, the United States could further decrease its imports of foreign petroleum from the increased displacement of petroleum transportation fuel by ethanol.

DOMINANT OWNERSHIP/FINANCING MODEL

Ethanol refineries predominantly have two ownership models: farmer and non-farmer (corporate refinery) owned. In 2005, farmer cooperatives or limited liability companies (LLC) owned nearly half of ethanol plants. In 2010, less than 20 percent of ethanol plants were farmer owned (RFA, 2010, p. 10). The decrease in farmer-owned refineries is primarily attributed to the acquisition or majority ownership stake of farmer-owned cooperative ethanol plants by POET, LLC (Urbanchuk, 2010, pp. 3-3). Most ethanol refineries are now owned and operated by biofuel corporations that purchase corn from U.S. farmers. While both ownership models generate significant economic activity, a study by the National Corn Growers Association concluded that farmer-owned ethanol plants tend to benefit the local economy as much as 56 percent more than corporate-owned plants (Urbanchuk, 2007). Comparing the locally owned ethanol refineries in 2010 with the list of current ethanol biorefineries, only 28 of the 35 refineries are remaining, making up just over 13 percent of total ethanol plants (RFA, 2020c; RFA, 2010, p. 10).

POLICIES TO ENCOURAGE ADOPTION

Policies (i.e., subsidies, tax incentives, and regulations) have been an important driver of industry growth since the debut of corn ethanol in the late 1970s and early 1980s. The first policy to support the ethanol industry was the Volumetric Ethanol Excise Tax Credit (VEETC), in effect between 1979 and 2010. The VEETC provided a tax incentive in the amount of \$0.45 for every gallon of ethanol blended with gasoline. This section discusses current policies encouraging the growth of the ethanol industry in the United States.

Renewable Fuel Standard

The Renewable Fuel Standard (RFS) was established in 2005 through the Energy Policy Act of 2005 (EPAct) and expanded under the Energy Independence and Security Act of 2007 (EISA), sometimes referred to as RFS2. The RFS mandates that U.S. transportation fuels contain an increasing quantity of renewable fuels. In 2006, the mandate required 4.0 billion gallons of renewable fuel, which was ratcheted up to the current target of 36 billion gallons of renewable fuel by 2022 (*exhibit 6-12*) (CRS, 2019, p. 2). Annual RFS-mandated volume requirements through 2019 show an incremental increase, with requirements for 2022 and beyond yet to be established. *Exhibit 6-12* shows the difference between EISA mandates and RFS requirements through 2019.

EXHIBIT 6-12: Renewable Fuel Standard Volume Requirements

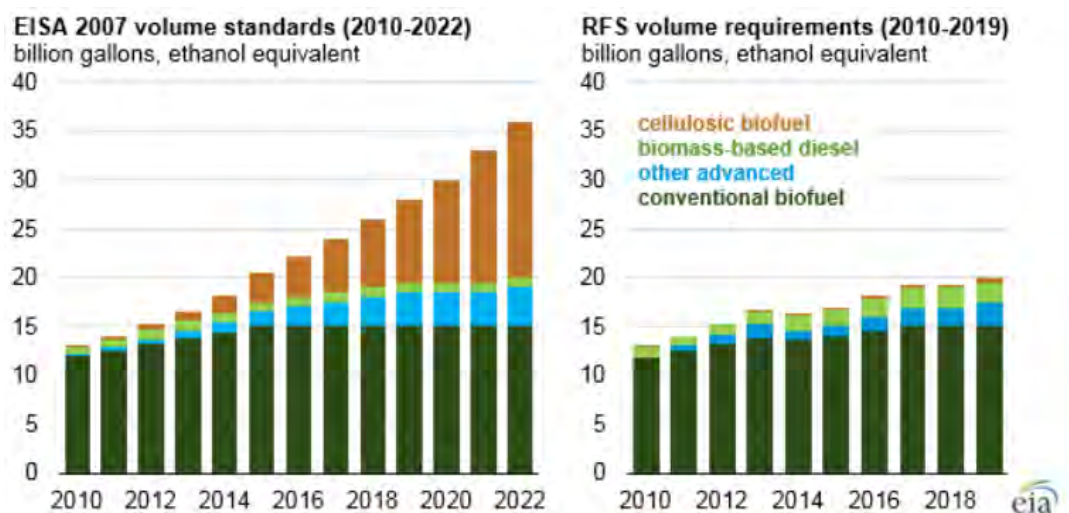

Source: EIA, 2018c.

In the RFS, corn starch ethanol is implicitly limited to 15 billion gallons in order to catalyze the growth of other advanced biofuels (including cellulosic ethanol), which are defined as biofuels having 50 percent lower GHG emissions than the fossil fuels they replace (Joint Biofuels Institute, n.d.).²¹⁷ Despite the implicit cap on corn starch ethanol, the RFS continues to be a key driver for ethanol production in the United States. The RFS compliance mechanisms are the Renewable Volume Obligation program and the Renewable Identification Number program.

Renewable Volume Obligation (RVO)

Using projections from the EIA, the EPA estimates annual consumption of transportation fuel volume in the US for each year. With these projections, the renewable volume obligation (RVO) is determined based on the percentage of this expected nationwide fuel consumption. Under EPA's RFS program, a small refinery may be granted a temporary exemption from its annual RVOs if it can demonstrate that compliance with the RVOs would cause the refinery to suffer disproportionate economic hardship.²¹⁸ RVO targets represent the percentage per volume required to be renewable fuels (EIA, 2013).

Renewable Identification Number (RIN)

A RIN is a credit that is generated for each gallon of renewable fuel produced and provides both a recordkeeping and flexibility components to the program. RINs are sold with the ethanol and are separated from the ethanol when it is blended into on-road gasoline. Traditional corn-based ethanol is assigned a RIN D-code of 6 (D6) and is defined as ethanol produced from corn starch that meets a minimum life cycle GHG reduction of 20 percent. Advanced biofuels, which are assigned D5 RINs, are produced from non-corn starch or renewable biomass and meet a minimum life cycle GHG reduction of 50 percent. Biodiesel, also considered an advanced biofuel, is assigned D4 RINs and is required to be produced from biomass and meet a minimum life cycle GHG reduction of 50 percent. Blenders can sell these separated RINs to obligated parties, generally refiners and importers of gasoline, who purchase them to prove compliance with their RVOs.

²¹⁷ As stated, the cap of 15 billion gallons is implicit because the actual cap is determined based on subtracting the cellulosic and other advanced biofuel quantities from the overall renewable fuels volume.

²¹⁸ Under EPA's RFS program, a small refinery may be granted a temporary exemption from its annual RVOs if it can demonstrate that compliance with the RVOs would cause the refinery to suffer disproportionate economic hardship. The definition of *small refinery* is available on the EPA website at <https://www.epa.gov/renewable-fuel-standard-program/renewable-fuel-standard-exemptions-small-refineries>

In early 2018, EPA granted several small refinery exemptions waiving the RVOs of specific refineries for 2016 and 2017. As can be seen in *exhibit 6-13*, the number of exemptions granted for 2016 and 2017 was 54, for a total of almost 25 billion gallons of gasoline between the two compliance years. It is important to note that the EPA does not redistribute the exempted blend volumes to non-exempt refineries.

EXHIBIT 6-13: Summary of Small Refinery Exemption Decisions and Exempted Volume of Gasoline and Diesel by Compliance Year

Compliance Year	Number of Petitions Received	Number of Grants Issued	Estimated Volumes of Gasoline and Diesel Exempted (million gallons)	Estimated Renewable Volume Obligations (RVO) Exempted (million RINs)
2013	26	8	1,980	190
2014	24	8	2,300	210
2015	24	7	3,070	290
2016	27	19	7,840	790
2017	37	35	17,050	1,820
2018	44	31	13,420	1,430
2019	27	0	0	0
2020	1	0	0	0

Source: EPA, 2020, tables 1 and 2.

Small refinery exemptions resulted in D6 RIN values falling substantially. Ethanol RIN values fell in 2016 from approximately \$0.85/gal (approximated from *exhibit 6-14*) to \$0.51/gal for advanced ethanol and \$0.80/gal (approximated from *exhibit 6-14*) to \$0.31/gal for conventional ethanol in 2018 (FAPRIMU, 2019, p. 51). However, advanced ethanol RIN values are expected to increase back to \$0.99/gal by 2020 and then begin to gradually decrease, while conventional ethanol continues to gradually fall over the next decade (*exhibit 6-14*) (FAPRIMU, 2019). It is unclear what impact the recent E15 RVP waiver will have on the RIN market,

EXHIBIT 6-14: Renewable Identification Number (RIN) Past and Projected Values

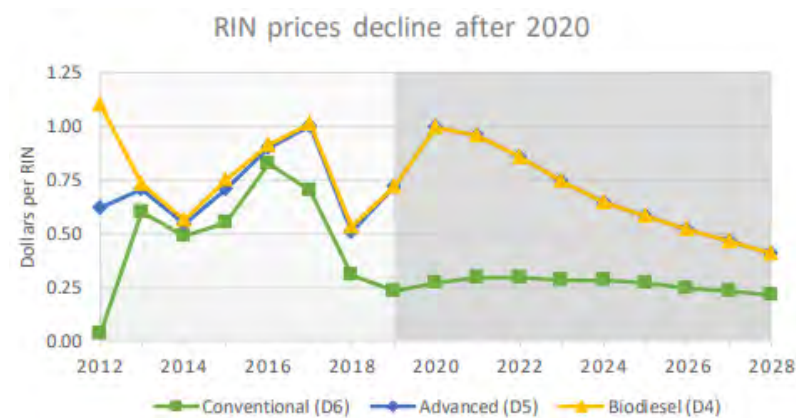

Source: FAPRIMU, 2019.

although many of the renewable fuel associations expect the change to have a negative impact on the RIN valuation, but a positive impact on the value of ethanol. The price per gallon of Iowa ethanol increased from approximately \$1.20/gal in May 2019 to \$1.50/gal in June 2019 following EPA's May 30, 2019, final rulemaking extending the RVP waiver to 15 percent ethanol.

Federal Incentive Programs

Several Federal incentive programs currently exist to support growth and innovation in the ethanol industry. Most target the development of ethanol derived from non-grain feedstocks (notably cellulosic feedstocks). *Exhibit 6-15* summarizes seven such incentive programs (mostly loans, loan guarantees, and grants). Currently, tax incentives and subsidies are only eligible for cellulosic ethanol. Federal supply-side incentives are focused on increasing the production of advanced biofuel (particularly cellulosic biofuel).

EXHIBIT 6-15: Federal Biofuel Development Assistance Programs

Federal Incentive Program	Description	Fuel Type
Advanced Biofuel Feedstock Incentives	The Biomass Crop Assistance Program (Section 9010) offers financial support to owners and operators of agricultural land who plan to produce biomass feedstock for cellulosic biofuel production. Financial assistance comes in two forms: (1) a maximum of 50 percent reimbursement for the cost of developing a biomass feedstock crop and annual payments for up to 5 years; and (2) matching payments for the collection, harvest, storage, and delivery of feedstocks to biomass conversion facilities (e.g., E85) (USDA, n.d.).	Typically for cellulosic biofuel production
Advanced Biofuel Production Grants and Loan Guarantees	The Biorefinery Assistance Program offers loan guarantees of up to \$250 million for the development, construction, and retrofitting of commercial-scale biorefinery facilities producing advanced biofuel. Maximum grant funding is 50 percent of total project costs (USDA, 2015a).	Typically for advanced or cellulosic biofuel facilities
Ethanol Infrastructure Grants and Loan Guarantees	Both the Section 9007 Rural Energy for America Program (REAP) and Business and Industry Loan Guarantee program offer loan guarantees and grants to agricultural producers and small businesses. Funding for renewable energy systems including ethanol production systems may be eligible for grants ranging from \$2,500 up to \$500,000, and loan guarantees ranging from \$5,000 to \$25 million (subject to congressional appropriations) (USDA, 2015b).	All biofuel types are eligible
Improved Energy Technology Loans	Funded by the U.S. Department of Energy (DOE), the Improved Energy Technology Loans program provides loan guarantees, up to 100 percent of the amount of the loan requested, to support nascent advanced technologies, including biofuels (DOE, n.d.-b).	Novel biofuel technologies that avoid or sequester GHGs are eligible
Value-Added Producer Grants (VAPG)	VAPG offers either planning or working capital grants that support independent agricultural producers, farmer and rancher cooperatives, agricultural producer groups, and majority-controlled producers-based business ventures (USDA, 2015c).	All biofuel technologies and co-products are eligible
Alternative Fuel Vehicle Refueling Property Credit	The Internal Revenue Service provides a 30 percent credit, up to \$30,000, for the cost of installing alternative fuel pumps (e.g., E85 fuel pump) (U.S. House of Representatives, 2020).	Ethanol, NG, CNG, LNG, LPG, Hydrogen, Biodiesel
Higher Blends Incentive Infrastructure Program (HBIIIP)	In May 2020, USDA approved \$100 million for the Higher Blends Infrastructure Incentive Program, which will offer grants and sales incentives for upgrading retail infrastructure to handle E15 and other higher biofuel blends (USDA, 2020b; USDA, 2020c). See below for a description of the Biofuels Infrastructure Partnership (BIP) program.	Higher ethanol blends (E10) and fuels that are greater than 5 percent biodiesel (B05)

State Greenhouse Gas Emissions Reduction Policies

State-mandated GHG emissions reduction legislation exists in 23 U.S. States (C2ES, 2019). Of the six highest ethanol-producing States (in descending order: Iowa, Nebraska, Illinois, Minnesota, Indiana, and South Dakota), two—Illinois and Minnesota—have GHG reduction targets in place (EIA, 2016).

In California, following the adoption of a higher ethanol blending limit from 5.7 percent to 10 percent in 2010, ethanol consumption significantly increased. In order to ensure that higher quantities of ethanol consumed in the State were in line with California's GHG policies, the Low Carbon Fuel Standard (LCFS) was adopted in 2009 and was implemented in 2011. California's LCFS has influenced the decline in the carbon intensity (CI) of ethanol fuel consumed in the State. Interested entities are required to apply for a fuel 'pathway,' which establishes a unique carbon intensity specific to the pathway.²¹⁹ The LCFS offers a significant financial incentive for refineries to lower the carbon intensity of their ethanol with

²¹⁹ Up until 2015, entities applying for the LCFS had the option to use a default carbon intensity value for ethanol; however, beginning in 2016 the ethanol default was removed.

credit generation commensurate and proportional with carbon intensity reductions compared to the annual standard. LCFS credits are trading for an average price of \$200 so far in 2020 which results in per gallon values exceeding RIN prices (CARB, 2020a). At the beginning of the program, the average CI of ethanol fuel was 78.28 grams of carbon dioxide equivalent per megajoule (gCO₂e/MJ); in 2019, the CI dropped to 66.01 gCO₂e/MJ (exhibit 6-16).²²⁰ GHG emissions reduction policies that target transportation fuels and agriculture will encourage increased adoption of corn ethanol, particularly in States that incentivize lower carbon fuels.

EXHIBIT 6-16: Average Carbon Intensity for LCFS Ethanol Pathways, 2011-2019 (Q2)

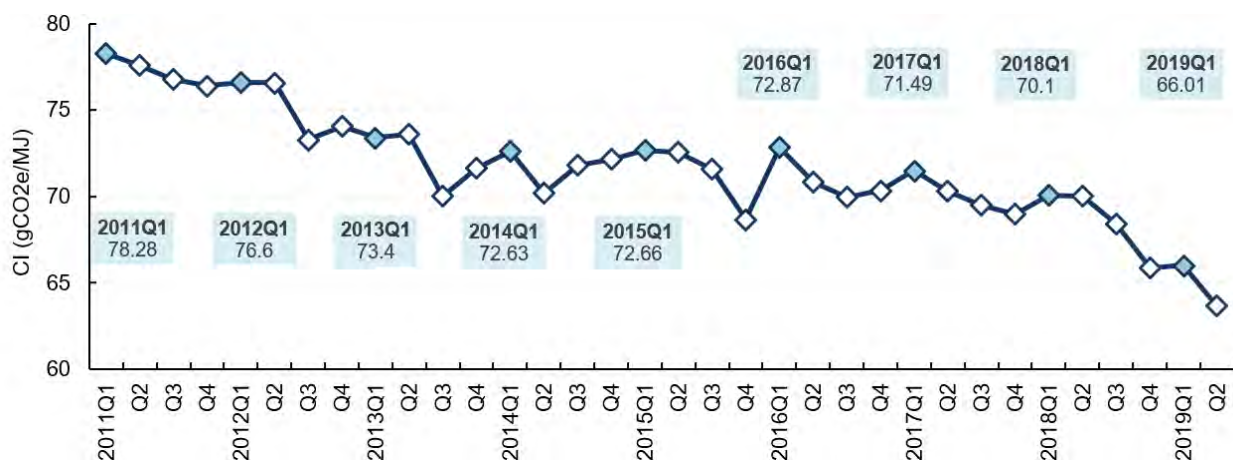

Source: CARB, 2020b.

²²⁰ More information is available in the ICF report *California Low Carbon Fuel Standard: Incentivizing Greenhouse Gas Mitigation in the Ethanol Industry* (ICF, 2020).

CHALLENGES TO EXTENDING ADOPTION

The ethanol industry significantly increased installed capacity following the 2008 recession and plateaued around 2011 when the installed capacity hit the 15-billion-gallon limit on conventional biofuels in the RFS. In 2018, the ethanol industry experienced its first decline in U.S. domestic ethanol consumption (*exhibit 6-17*) due to a small decline in national gasoline consumption and a significant increase in the granting of small refinery exemptions by EPA (RFA, 2018a, p. 2). This section discusses three challenges to increasing the use of corn ethanol going forward.

EXHIBIT 6-17: U.S. Domestic Ethanol Consumption, 2000 – 2018

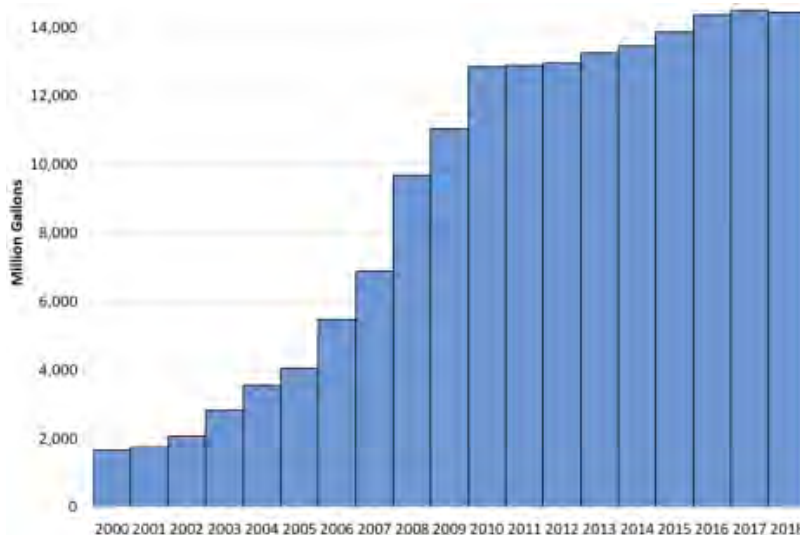

Source: RFA, 2018a.

Transportation Infrastructure Expansion

As noted above, ethanol production is concentrated in the U.S. Midwest. Corn production among the six Midwestern States (Illinois, Indiana, Iowa, Minnesota, Nebraska, and South Dakota) account for more than 70 percent of U.S. ethanol production (EIA, 2016). The concentration of ethanol production in the Midwest, and the presence of rail lines previously installed to move agricultural products to the cities, make rail the most cost-effective method to move ethanol to blenders located near population centers around the country (Rusco, 2012).

Petroleum terminals in western and southern cities typically have rail access, and thus can receive ethanol from railcars directly into the rack for blending. Many eastern cities, however, removed train access into their petroleum terminals. In these cities, ethanol must be loaded into trucks for the last few miles between the rail terminals and the blending facilities. This marginally increases the cost of fuel to cities in the Northeast. There has been limited progress on installing ethanol pipelines due largely to ethanol's potential to corrode existing pipelines. This means that existing pipelines cannot be used or extended to move ethanol. Additionally, ethanol refineries tend to be sited near existing rail lines to optimize transportation logistics (*exhibit 6-18*). As a result, transport by railcar is likely to remain the predominant shipping method for the foreseeable future (Rusco, 2012).

EXHIBIT 6-18: Ethanol Refineries and Railroad Infrastructure



Source: NREL, 2019.

Retail Infrastructure Expansion

Currently, there are just over 2,000 retail stations in 30 States offering E15 compared with more than 115,000 retail gasoline stations;²²¹ however, the majority of E15 stations are concentrated in the Midwest (Census Bureau, 2017). The increased cost to station owners installing a pump to dispense E15 could be a limiting factor to its implementation. USDA, however, launched the Biofuels Infrastructure Partnership in 2015, which provided funding for ethanol infrastructure, including dedicated and blender pumps for E15 and E85 (USDA, 2020c). While this program has ended, USDA has initiated a similar program called the Higher Blends Incentive Infrastructure Program (see *exhibit 6-15*). Since products must be available to consumers, it is vital that investments continue to target the expansion of higher ethanol blend fueling stations.

Consumer Acceptance

One key factor that will influence ethanol demand going forward is how consumers react to higher ethanol blends as an option at the pump. Over 93 percent of all new vehicles sold are now warranted by their manufacturers to use E15. This should help address earlier consumer concerns about voiding their vehicle warranties by using blends above E10. Still, because of its limited geographical availability, there is not a good understanding on how consumer demand will behave when offered E15 (and higher blends) (RFA, 2018b; American Coalition for Ethanol, 2020).

²²¹ U.S. EPA defines E15 as gasoline blended with 10.5 percent to 15 percent ethanol. More information on E15 can be found at: https://afdc.energy.gov/fuels/ethanol_e15.html

End-Use Technologies

The overwhelming end-use technology for ethanol is in internal combustion engine vehicles, primarily as a fuel additive to increase the octane rating (EIA, 2018d). Opportunities for ethanol industry growth are likely to come from wider adoption of higher gasoline-ethanol blends, including E15 and E85 (*exhibit 6-19*). E85, which can currently only be used in flexible-fuel vehicles (FFVs), could significantly increase ethanol adoption either through policies mandating its use and/or increased consumer demand. It is important to note, though that U.S. gasoline consumption is projected to slowly decline (see *exhibit 6-6*) over the next 10 years.

As of February 2019, nine automobile manufacturers collectively offered 39 FFV models, with the majority being SUV and truck models, and a few sedans (DOE, 2019d). More than 21 million FFVs are currently operating on U.S. roads (DOE, 2019b). The current trend of vehicle electrification in the light-duty vehicle sector (including the growing popularity of hybrids, plug in hybrids, and battery electric vehicles) indicate FFV cars will not likely gain additional market share in the future. According to EIA, battery electric vehicles will experience the highest levels of growth compared with any other vehicle type in the light-duty vehicle segment, with FFVs retaining essentially the same market penetration through 2050 (*exhibit 6-19*). In the absence of a general shift to E15, current trends in automotive technologies indicate a reduction in overall ethanol consumption, at least over the next decade.

EXHIBIT 6-19: U.S. Light-Duty Vehicle Sales Projections by Powertrain Technology

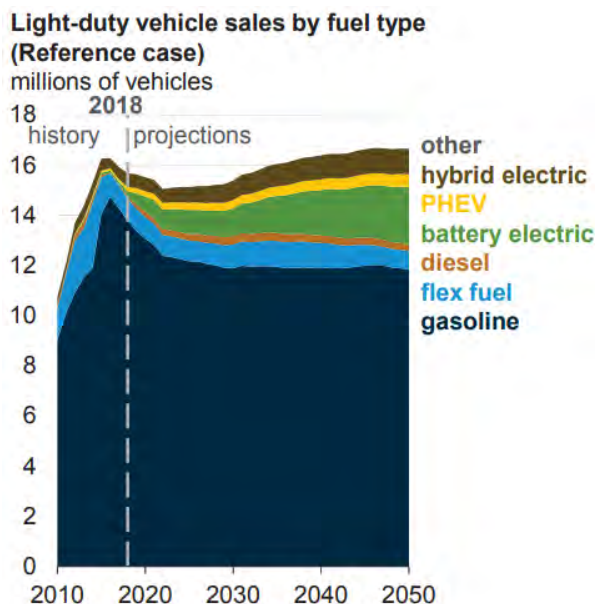

Source: EIA, 2019e.

REFERENCES

- Albrecht, T. 2018. The Way Forward. Ethanol Producer Magazine. <http://www.ethanolproducer.com/articles/15425/undefinedthe-way-forwardundefined> [accessed June 2020].
- American Coalition for Ethanol. 2020. E15: Drive Away the Misinformation. American Coalition for Ethanol. <https://ethanol.org/ethanol-essentials/facts-about-e15> [accessed May 2020].
- Arora, S., Wu, M., & Wang, M. 2008. Update of Distillers Grains Displacement. Argonne National Laboratory: Energy Systems Division. <https://greet.es.anl.gov/publication-3bi0z09m> [accessed June 2020].
- BBI International. 2019. Construction of first D2MAX plant nears completion. Ethanol Producer Magazine. <http://www.ethanolproducer.com/articles/16717/construction-of-first-d3max-plant-nears-completion> [accessed May 2020].
- C2ES. 2019. U.S. State Greenhouse Gas Emissions Targets. Center for Climate and Energy Solutions. <https://www.c2es.org/document/greenhouse-gas-emissions-targets/> [accessed June 2020].
- CARB. 2020a. Weekly LCFS Credit Transfer Activity Reports. California Air Resources Board. <https://ww3.arb.ca.gov/fuels/lcfs/credit/lrtweeklycreditreports.htm> [accessed May 2020].
- CARB. 2020b. LCFS Pathway Certified Carbon Intensities. California Air Resources Board. <https://ww2.arb.ca.gov/resources/documents/lcfs-pathway-certified-carbon-intensities> [accessed June 2020].
- Census Bureau. 2017. All Sectors: Summary Statistics for the U.S., States, and Selected Geographies: 2017. Economic Census. <https://data.census.gov/cedsci/table?q=gas%20station&hidePreview=false&tid=ECNBASIC2017.EC1700BASIC&n=447&vintage=2018> [accessed June 2020].
- Christianson CPAs & Consultants. 2020. *Ethanol Efficiency Gains and Benchmark Data*. https://www.mda.state.mn.us/sites/default/files/inline-files/MARCH%202020%20ETHANOL%20EFFICIENCIES_svb.pdf [accessed May 2020].
- Clifford, C. B. 2018. How is Corn Processed to Make Ethanol. Penn State – College of Earth and Mineral. <https://www.e-education.psu.edu/egee439/node/673> [accessed May 2020].
- CRS. 2019. *The Renewable Fuel Standard (RFS): An Overview*. Congressional Research Service. <https://fas.org/sgp/crs/misc/R43325.pdf> [accessed June 2020].
- Davis, K. (2018). *California LCFS Updates*. Renewable Fuels Association. https://ethanolrfa.org/wp-content/uploads/2018/11/California-LCFS-Updates_BFC_2018.pdf [accessed June 2020].
- De Kam, M. J., Morey, R. V., & Tiffany, D. G. 2009. Integrating biomass to produce heat and power at ethanol plants. *Applied Eng. in Agric.*, 227-244.
- DOE. 2018. *Ethanol Basics*. Alternative Fuels Data Center. https://afdc.energy.gov/files/u/publication/ethanol_basics.pdf [accessed June 2020].
- DOE. 2019a. Corn Production and Portion Used for Fuel Ethanol. Alternative Fuels Data Center. <https://afdc.energy.gov/data/10339> [accessed June 2020].
- DOE. 2019b. Alternative Fueling Station Counts by State. Alternative Fuels Data Center. <https://afdc.energy.gov/stations/states> [accessed June 2020].
- DOE. 2019c. Ethanol Benefits and Considerations. Alternative Fuels Data Center. https://afdc.energy.gov/fuels/ethanol_benefits.html [accessed June 2020].
- DOE. 2019d. *Alternative Fuel and Advanced Technology Vehicles*. Alternative Fuels Data Center. https://afdc.energy.gov/files/u/publication/model_year_2019_afv.pdf [accessed June 2020].
- DOE. n.d.-a POET-DSM: Project Liberty. U.S. Department of Energy. <https://www.energy.gov/eere/bioenergy/poet-dsm-project-liberty> [accessed May 2020].
- DOE. n.d.-b Improved Energy Technology Loans. Alternative Fuels Data Center. <https://afdc.energy.gov/laws/392> [accessed May 2020].
- EIA. 2013. RINs and RVOs are used to implement the Renewable Fuel Standard. U.S. Energy Information Administration, DOE. <https://www.eia.gov/todayinenergy/detail.php?id=11511> [accessed June 2020].
- EIA. 2015. Corn ethanol yields continue to improve. U.S. Energy Information Administration, DOE. <https://www.eia.gov/todayinenergy/detail.php?id=21212> [accessed May 2020].
- EIA. 2016. Six states account for more than 70% of U.S. fuel ethanol production. U.S. Energy Information Administration, DOE. <https://www.eia.gov/todayinenergy/detail.php?id=36892> [accessed June 2020].
- EIA. 2018a. U.S. exported a record amount of fuel ethanol in 2017. U.S. Energy Information Administration, DOE. <https://www.eia.gov/todayinenergy/detail.php?id=35972> [accessed June 2020].

- EIA. 2018b. U.S. Fuel Ethanol Plant Production Capacity. U.S. Energy Information Administration, DOE. <https://www.eia.gov/petroleum/ethanolcapacity/> [accessed August 2020].
- EIA. 2018c. EPA finalizes Renewable Fuel Standard for 2019, reflecting cellulosic biofuel shortfalls. U.S. Energy Information Administration, DOE. <https://www.eia.gov/todayinenergy/detail.php?id=37712> [accessed May 2020].
- EIA. 2018d. The United States continues to export MTBE, mainly to Mexico, Chile, and Venezuela. U.S. Energy Information Administration, DOE. <https://www.eia.gov/todayinenergy/detail.php?id=36614> [accessed May 2020].
- EIA. 2019a. Monthly Energy Review. U.S. Energy Information Administration, DOE. <https://www.eia.gov/totalenergy/data/monthly/#renewable> [accessed July 2019].
- EIA. 2019b. Biofuels: Ethanol and Biodiesel, Explained. U.S. Energy Information Administration, DOE. https://www.eia.gov/energyexplained/index.php?page=biofuel_biodiesel_home [accessed July 2019].
- EIA. 2019c. PADD regions enable regional analysis of petroleum product supply and movements. U.S. Energy Information Administration, DOE. <https://www.eia.gov/todayinenergy/detail.php?id=4890> [accessed August 2019].
- EIA. 2019d. EIA expects stable U.S. biofuels production, consumption, and trade through 2020. U.S. Energy Information Administration, DOE. <https://www.eia.gov/todayinenergy/detail.php?id=38532> [accessed July 2019].
- EIA. 2019e. *Annual Energy Outlook 2019*. U.S. Energy Information Administration, DOE. <https://www.eia.gov/outlooks/aeo/pdf/aeo2019.pdf> [accessed June 2020].
- EIA. 2019f. Biomass Explained: Biomass and the Environment. U.S. Energy Information Administration, DOE. <https://www.eia.gov/energyexplained/biomass/biomass-and-the-environment.php#:~:text=Energy%20Information%20Administration%20-%20EIA%20-%20Official%20Energy,impacts%20of%20producing%20and%20using%20biomass%20for%20energy> [accessed August 2020].
- EIA. 2020a. *Annual Energy Outlook 2020*. U.S. Energy Information Administration, DOE. <https://www.eia.gov/outlooks/aeo/pdf/AEO2020%20Full%20Report.pdf> [accessed June 2020].
- EIA. 2020b. Natural Gas Spot and Future Prices (NYMEX). U.S. Energy Information Administration, DOE. <https://www.eia.gov/dnav/ng/hist/rngwhhdm.htm> [accessed June 2020].
- EIA. 2020c. *Monthly Biodiesel Production Report*. U.S. Energy Information Administration, DOE. <https://www.eia.gov/biofuels/biodiesel/production/biodiesel.pdf> [accessed May 2020].
- EPA. 2018. Biofuels and the Environment: The Second Triennial Report to Congress. U.S. Environmental Protection Agency. https://cfpub.epa.gov/si/si_public_record_report.cfm?Lab=IO&dirEntryId=341491 [accessed August 2020].
- EPA. 2019. *Inventory of U.S. Greenhouse Gas Emissions and Sinks*. U.S. Environmental Protection Agency. <https://www.epa.gov/sites/production/files/2019-04/documents/us-ghg-inventory-2019-main-text.pdf> [accessed June 2020].
- EPA. 2020. RFS Small Refinery Exemptions. U.S. Environmental Protection Agency. <https://www.epa.gov/fuels-registration-reporting-and-compliance-help/rfs-small-refinery-exemptions> [accessed May 2020].
- FAPRIMU. 2019. *U.S. Baseline Outlook*. Food and Agricultural Policy Research Institute. <https://www.fapri.missouri.edu/wp-content/uploads/2019/04/2019-US-Baseline-Outlook.pdf> [accessed July 2019].
- Hofstrand, D. 2020. Ag Decision Maker, D1-10 Ethanol Profitability. University of Missouri. <https://www.extension.iastate.edu/agdm/energy/xls/d1-10ethanolprofitability.xlsx> [accessed June 2020].
- ICF. 2020. *California Low Carbon Fuel Standard: Incentivizing Greenhouse Gas Mitigation in the Ethanol Industry*. <https://www.usda.gov/sites/default/files/documents/ethanol-mitigation-options-2020>
- ICM. 2009. *Bio-Methanation: Waste to Energy*. <https://d3pcsg2wj9izr.cloudfront.net/files/27000/download/364126/BioMethanation.pdf> [accessed July 2019].
- ILSR. 1995. *How Much Energy Does It Take to Make Ethanol?* Institute for Local Self-Reliance. <https://ilsr.org/wp-content/uploads/files/ethanolnetenergy.pdf> [accessed June 2020].
- Irwin, S. 2019. How Tough of a Year was 2018 for Ethanol Production Profits? University of Illinois. <https://farmdocdaily.illinois.edu/2019/02/how-tough-of-a-year-was-2018-for-ethanol-production-profits.html> [accessed July 2019].
- Joint Biofuels Institute. n.d. Why Advanced Biofuels. U.S. Department of Energy. <https://www.jbei.org/about/mission/why-advanced-biofuels/> [accessed June 2020].
- Lark, T. J., Salmon, J. M., & Gibbs, H. H. 2015. *Cropland expansion outpaces agricultural and biofuel policies in the United States*. Environmental Research Letters, 10(4). <https://doi.org/DOI: 10.1088/1748-9326/10/4/044003> [accessed September 2020].

- Luangthongkam, P., Fang, L., Noomhorm, A., & Lamsal, B. 2015. Addition of cellulolytic enzymes and phytase for improving ethanol fermentation performance and oil recovery in corn dry grind process. *Ind. Crop. Prod.*, 803–808.
- Morey, V. 2011. *Using Biomass at Ethanol Plants for Combined Heat and Power (CHP)*. University of Minnesota. <https://www.eesi.org/files/4-MoreyWorkshopBiomass.pdf> [accessed July 2019].
- Motamed, M., McPhail, L., & Williams, R. 2016. *Corn area response to local ethanol markets in the United States: A grid cell level analysis*. *American Journal of Agricultural Economics*, 98(3), 726-743. <https://doi.org/10.1093/ajae/aav095> [accessed September 2020].
- NREL. 2019. The Biofuels Atlas. National Renewable Energy Laboratory. <https://maps.nrel.gov/biofuels-atlas/?aL=Axnsht%255Bv%255D%3Dt&bL=clight&cE=0&lR=0&mC=36.80928470205937%2C-90.4833984375&zL=5> [accessed June 2020].
- Pamuk, H., & Renshaw, J. 2019. Trump's EPA grants 31 small refinery waivers from biofuel laws, angering corn lobby. *Rueters*. <https://www.reuters.com/article/us-usa-ethanol-epa/trumps-epa-grants-31-small-refinery-waivers-from-biofuel-laws-angering-corn-lobby-idUSKCN1UZ2AV> [accessed May 2020].
- RFA. 2010. *2010 Ethanol Industry Outlook: Climate of Opportunity*. Renewable Fuels Association. https://ethanolrfa.org/wp-content/uploads/2015/09/RFAoutlook2010_fin.pdf [accessed July 2019].
- RFA. 2018a. *Small Refinery Exemptions Reduced 2018 Ethanol Consumption and Blend Rate*. Renewable Fuels Association. <https://ethanolrfa.org/wp-content/uploads/2019/03/Small-Refinery-Exemption-Impact-on-2018-Ethanol-ConsumptionFINAL.pdf> [July 2019].
- RFA. 2018b. Automakers explicitly approve E15 for 93% of new 2019 vehicles. *Ethanol Producer Magazine*. <http://ethanolproducer.com/articles/15715/automakers-explicitly-approve-e15-for-93-of-new-2019-vehicles> [accessed June 2020].
- RFA. 2019a. *2019 Ethanol Industry Outlook*. Renewable Fuels Association. <https://ethanolrfa.org/wp-content/uploads/2019/02/RFA2019Outlook.pdf> [accessed July 2019].
- RFA. 2019b. *2018 U.S. Ethanol Exports and Imports Statistical Summary*. Renewable Fuels Association. <https://ethanolrfa.org/wp-content/uploads/2019/03/2018-US-Ethanol-Trade-Statistics-Summary.pdf> [accessed July 2019].
- RFA. 2020a. Ethanol Co-products. Renewable Fuels Association. <https://ethanolrfa.org/co-products/> [accessed June 2020].
- RFA. 2020b. Rural Economy: Ethanol Renewing the Heartland. Renewable Fuels Association. <https://ethanolrfa.org/rural-economy/> [accessed August 2020].
- RFA. 2020c. Ethanol Biorefinery Locations. Renewable Fuels Association. <https://ethanolrfa.org/biorefinery-locations/> [accessed June 2020].
- Rosenfeld, J., Lewandrowski, J., Hendrickson, T., Jaglo, K., Moffroid, K., & Pape, D. 2018. *A Life-Cycle Analysis of the Greenhouse Gas Emissions from Corn-Based Ethanol*. U.S. Department of Agriculture. https://www.usda.gov/oce/climate_change/mitigation_technologies/LCA_of_Corn_Ethanol_2018_Report.pdf [accessed July 2019].
- Rusco, F. 2012. *Biofuels Infrastructure in the United States: Current Status and Future Challenges*. Organization for Economic Co-operation and Development. <https://www.oecd.org/futures/Biofuels%20Infrastructure%20in%20the%20United%20States%20Current%20Status%20and%20Future%20Challenges.pdf> [accessed June 2020].
- U.S. Grains Council. 2018. *Emerging Technologies in Ethanol Production and Nutritional Composition of the High Protein Corn Co-Products Produced*. <https://grains.org/wp-content/uploads/2018/07/Chapter-5.pdf> [accessed May 2020].
- U.S. House of Representatives. 2020. 26 USC 30C: Alternative fuel vehicle refueling property credit. Office of the Law Revision Counsel United States Code. [https://uscode.house.gov/view.xhtml?req=\(title:26%20section:30C%20edition:prelim\)](https://uscode.house.gov/view.xhtml?req=(title:26%20section:30C%20edition:prelim)) [accessed June 2020].
- Urbanchuk, J. 2007. Economic Impacts on the Farm Community of Cooperative Ownership of Ethanol Production. *Farm Progress*. <https://www.farmprogress.com/farmer-owned-ethanol-plants-contribute-more-local-economies> [accessed July 2019].
- Urbanchuk, J. 2010. *Current State of the U.S. Ethanol Industry*. U.S. Department of Energy. https://www.energy.gov/sites/prod/files/2014/04/f14/current_state_of_the_us_ethanol_industry.pdf [accessed July 2019].
- USDA. 1999. *Crop Production*. U.S. Department of Agriculture. <https://downloads.usda.library.cornell.edu/usda-esmis/files/tm70mv177/fn106z825/9c67wn55n/CropProd-07-12-1999.pdf> [accessed June 2020].
- USDA. 2015a. Biorefinery, Renewable Chemical, and Biobased Product Manufacturing Assistance. U.S. Department of Agriculture. <https://www.rd.usda.gov/programs-services/biorefinery-renewable-chemical-and-biobased-product-manufacturing-assistance> [accessed May 2020].

- USDA. 2015b. Rural Energy for America Program Renewable Energy Systems & Energy Efficiency. U.S. Department of Agriculture. <https://www.rd.usda.gov/programs-services/rural-energy-america-program-renewable-energy-systems-energy-efficiency> [accessed May 2020].
- USDA. 2015c. Value Added Producer Grants. U.S. Department of Agriculture. <https://www.rd.usda.gov/programs-services/value-added-producer-grants> [accessed April 2020].
- USDA. 2018a. Feedgrains Sector at Glance. U.S. Department of Agriculture. <https://www.ers.usda.gov/topics/crops/corn-and-other-feedgrains/feedgrains-sector-at-a-glance/> [accessed May 2019].
- USDA. 2018b. Quick Stats. U.S. Department of Agriculture. <https://quickstats.nass.usda.gov/results/C77C3D76-7B56-3B06-8D11-EC34BC546404> [accessed May 2019].
- USDA. 2019a. U.S. Bioenergy Statistics. U.S. Department of Agriculture. <https://www.ers.usda.gov/data-products/us-bioenergy-statistics/> [accessed May 2020].
- USDA. 2019b. *Crop Production 2018 Summary*. U.S. Department of Agriculture. https://www.nass.usda.gov/Publications/Todays_Reports/reports/cropan19.pdf [accessed May 2019].
- USDA. 2019c. *Crop Production*. U.S. Department of Agriculture. https://www.nass.usda.gov/Publications/Todays_Reports/reports/acrg0619.pdf [accessed May 2019].
- USDA. 2019d. Corn for Grain Production. U.S. Department of Agriculture. https://www.nass.usda.gov/Charts_and_Maps/Field_Crops/cornprod.php [accessed June 2020].
- USDA. 2019e. *Agricultural Projections to 2028*. U.S. Department of Agriculture. <https://www.ers.usda.gov/webdocs/outlooks/92600/oce-2019-1.pdf?v=7641> [accessed June 2020].
- USDA. 2019f. Fuel ethanol, corn, and gasoline prices, by month. U.S. Department of Agriculture. <https://www.ers.usda.gov/webdocs/DataFiles/53657/table14.xls?v=11> [accessed June 2020].
- USDA. 2020a. *Corn for Grain Yield*. U.S. Department of Agriculture. https://www.nass.usda.gov/Charts_and_Maps/graphics/cornyld.pdf [accessed May 2020].
- USDA. 2020b. USDA Announces \$100 Million for American Biofuels Infrastructure. U.S. Department of Agriculture. <https://www.usda.gov/media/press-releases/2020/05/04/usda-announces-100-million-american-biofuels-infrastructure> [accessed May 2020].
- USDA. 2020c. Higher Blends Infrastructure Incentive Program. U.S. Department of Agriculture. <https://www.rd.usda.gov/programs-services/higher-blends-infrastructure-incentive-program> [accessed June 2020].
- USDA. (n.d.). Biomass Crop Assistance Program. U.S. Department of Agriculture. <https://www.fsa.usda.gov/programs-and-services/energy-programs/BCAP/index> [accessed June 2020].
- USGS, 2020. Nutrients and Eutrophication. U.S. Geological Survey. https://www.usgs.gov/mission-areas/water-resources/science/nutrients-and-eutrophication?qt-science_center_objects=0#qt-science_center_objects [accessed August 2020].
- Wang, Z., Dunn, J., & Wang, M. 2014. *Updated to the Corn Ethanol Pathway and Development of an Integrated Corn and Corn Stover Ethanol Pathway in the GREET Model*. Argonne National Laboratory. <https://publications.anl.gov/anlpubs/2014/10/108233.pdf> [accessed July 2019].
- Wright C. & Wimberly C. 2013. *Recent land use change in the Western Corn Belt threatens grasslands and wetlands*. Proceedings of the National Academy of Sciences. USA 110 4134–9. <https://doi.org/10.1073/pnas.1215404110> [accessed September 2020].
- Wright, C. K., Larson, B., Lark, T., & Gibbs, H. 2017. *Recent grassland losses are concentrated around U.S. ethanol refineries*. Environmental Research Letters, 12, 044001. <https://doi.org/10.1088/1748-9326/12/4/044001> [accessed September 2020].
- xprt agriculture, G. C. 2019. Corn Oil Extraction Technology. <https://www.agriculture-xprt.com/products/corn-oil-extraction-technology-557338> [accessed June 2020].

7. Biodiesel and Renewable Diesel

INTRODUCTION

Biodiesel and renewable diesel offer a proven approach for decarbonizing the medium- and heavy-duty truck and freight transportation sectors. According to the U.S. Environmental Protection Agency's (EPA) *Inventory of U.S. Greenhouse Gas Emissions and Sinks (1990–2018)*, these two sources contribute roughly 27 percent of the total emissions from the transportation sector (*exhibit 7-1*) (EPA, 2020a, pp. 2-29).²²² Emissions from biodiesel and renewable diesel are significantly lower compared to petroleum diesel. A recent study by Argonne National Laboratory, Purdue University, and the U.S. Department of Agriculture (USDA) found that relative to conventional petroleum diesel, soy biodiesel could achieve a 66 percent to 76 percent reduction in greenhouse gas (GHG) emissions (Chen, et al., 2018).

Biodiesel and renewable diesel are both produced using the same feedstocks, and both types of fuels can be used in diesel engines with minimal to no modifications. Biodiesel and renewable diesel are produced from vegetable oils (virgin or post-consumer) or animal fats using different production steps, which result in different byproducts and characteristics (*exhibit 7-2*).

Unlike fossil fuel diesel, biodiesel contains oxygen atoms, typically in the form of a fatty acid methyl ester (FAME) or fatty acid ethyl ester (FAEE) (DOE, 2016, pp. 20, 252).²²³ Because of oxidative stability concerns, biodiesel is subject to blending limitations in many States. For example, California has limited the use of biodiesel to 5 percent in underground storage tanks, pending testing by Underwriters Laboratory (State of California, 2020).

EXHIBIT 7-1: U.S. Transportation Sector GHG Emissions by Source, 2018

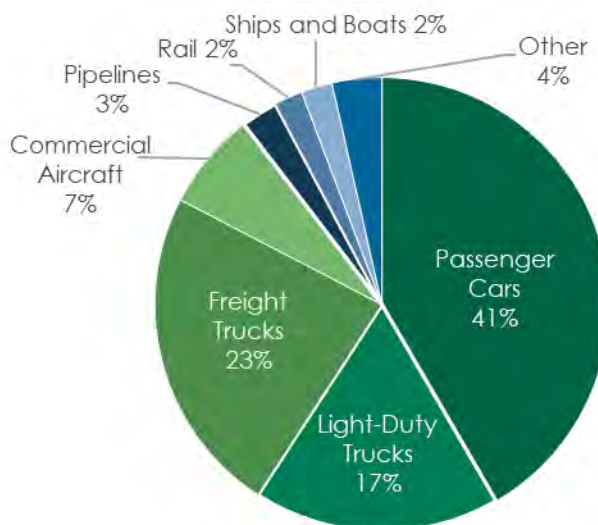

Source: EPA, 2020a, p. 2-29.

EXHIBIT 7-2: Biodiesel and Renewable Diesel Differences

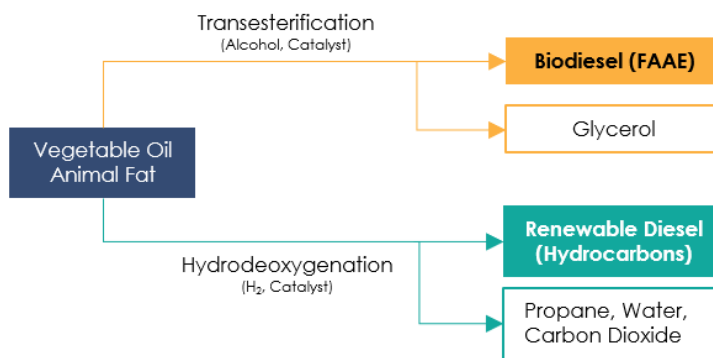

Source: ICF, adapted from Knothe, 2010.

²²² Freight includes the following categories: Freight Trucks, Rail, and Ships and Boats.

²²³ FAME is produced when methanol is used as the reactant to produce biodiesel, and FAEE is produced when ethanol is the reactant (Firdaus, 2014). Methanol has historically been more commonly used as a reactant because it has historically cost less than ethanol. However, there is renewed interest in the utilization of ethanol and the production of FAEE in recent years due to depressed ethanol prices (Cascone & Slome, 2019).

The body responsible for the biodiesel fuel standard, as well as the testing processes for complying with the standard in the United States, is ASTM International. Currently, there are three applicable standards, depending on the biodiesel blend percentage:

- ASTM D975, *Standard Specification for Diesel Fuel*, the diesel fuel standard in the United States, which allows for up to 5 percent blends of biodiesel
- ASTM D7467, *Standard Specification for Diesel Fuel Oil, Biodiesel Blend (B6 to B20)* for biodiesel blends between 6 percent and 20 percent
- ASTM D6751, *Standard Specification for Biodiesel Fuel Blend Stock (B100) for Middle Distillate Fuels*, for 100 percent biodiesel to be used as a blend stock under D975 and D7467

D975 allows for the blending of up to 5 percent biodiesel and its sale as conventional diesel, while many diesel engine manufacturers warrant their engines for biodiesel blends up to 20 percent (National Biodiesel Board, n.d.).

Renewable diesel has a similar chemical composition to conventional fossil fuel diesel and can be moved with fossil fuel diesel in common pipelines. Unlike with biodiesel, renewable diesel can be used at any blend level up to 100 percent.

There are six key takeaways about U.S. biodiesel refining:

- U.S. domestic production of biodiesel has grown significantly in the past two decades, with production at approximately 9 million gallons annually in 2001, rising to a peak of 1.86 billion gallons in 2018 (EIA, 2020a). Production data on renewable diesel is typically not tracked separately from biodiesel; however, annual production capacity is 356 million gallons (DOE, n.d.-a) and forecast to increase substantially in the next few years (ADI Analytics, 2020). The enactment of the Renewable Fuel Standard and the biodiesel production credit at the Federal level, along with a variety of State-level policies (e.g., low-carbon fuel policies), have been influential drivers of domestic biodiesel production and consumption.
- U.S.-based biodiesel production is overwhelmingly supplied by soybean oil, which accounts for more than 50 percent of total feedstocks. While biodiesel refineries are located throughout the country, production is centered in the Midwest, which has approximately 60 percent of installed capacity. In total, among major biodiesel feedstocks, there was an 89 percent increase in feedstock consumption between 2012 and 2018 (EIA, 2019a).
- Biodiesel production costs vary depending on plant capacity, process efficiency, feedstock costs, financing structure, and other variables. However, production costs are largely driven by feedstock costs; for example, for soybean oil biodiesel, the feedstock can account for more than 70 percent of the total cost to produce biodiesel.
- Biodiesel production has an array of economic and environmental benefits beyond its value as a fuel, including energy security, employment, GHG emissions benefits, improved engine operation, and lower vehicle maintenance costs.
- Further growth of biodiesel production will depend on several factors, including increasing consumer acceptance of biodiesel blends above B5, and addressing technical issues and infrastructural barriers that currently limit wider distribution and retail sale of these higher blends.
- The demand for biodiesel is heavily reliant on the medium- and heavy-duty trucking industry. This demand is expected to be stable over the next 10 years. There has been a limited shift to electric and natural gas alternative fuels in the medium- and heavy-duty diesel engine market to date, with most detractors referencing range and energy density issues (Kaufmann & Moynihan, 2019).

The remainder of this chapter includes the following sections:

- A technical characterization of the biodiesel refining process
- An overview of biodiesel feedstock production
- An overview of the current state of adoption and regional considerations
- A summary of adoption costs
- Highlights of the potential economic, environmental, and land use impacts of adopting biodiesel
- A discussion of the dominant ownership and financing models

- Highlights of key policy drivers for biodiesel fuel
- Challenges to extending adoption

TECHNOLOGY CHARACTERIZATION

The process for producing biodiesel can be traced back to the early 1940s. Biodiesel was produced to support wartime efforts for both the manufacture of glycerol, which was used for the production of explosives, and biodiesel which was used to operate tanks and other heavy vehicles (Gerpen, 2005).

Biodiesel Fuel Production

Although there are nuances in the unit operations between the various technologies for producing biodiesel, the overall chemistry of the process is the same and involves the following three operations:

- Pretreatment (degumming and acid esterification)
- Biodiesel production (transesterification)
- Refining (typically distillation)

Pretreatment (Degumming and Acid Esterification)

Before 2010, biodiesel production processes were designed to utilize virgin vegetable oils (generally soybean oil in the United States, palm oil in Southeast Asia, and rapeseed oil in Europe). Due to the increasing costs of these virgin oils, biodiesel plant owners and technology providers have designed and retrofit pretreatment operations to handle lower cost feedstocks such as used cooking oil, tallows, and distillers corn oil, all of which contain significantly greater concentrations of free fatty acids (FFAs) than virgin oils. In 2018, these low-cost, high-FFA feedstocks accounted for 13 percent of total biodiesel feedstock (EIA, 2019b).

Pretreatment, specifically acid esterification, is a necessary step for feedstocks that contain high concentrations of FFAs. The primary reason is that FFAs react with the catalyst used in the transesterification process—typically sodium or potassium methylate—to produce soaps that reduce the biodiesel yield and are difficult and expensive to remove. During the esterification process, FFAs are reacted with methanol, in the presence of an acid catalyst, to convert the FFA to fatty acid methyl ester (FAME) and water. This process is especially pertinent when the feedstock is yellow grease (e.g., used cooking oil) or brown grease (e.g., grease trap waste) that contains especially high FFA concentrations (Costello, R.C., 2018).

The pretreatment process begins with the mixing of waste vegetable oil (WVO) or fats with acid to produce FAME, after which the unreacted methanol and water are removed using a gravity phase separator. Next, the reaction and separation processes are repeated to convert unreacted FFAs from the first reaction step. The resulting pretreated oil or fat product of triglycerides and FAME is nearly FFA-free and can be used in the next processing step—transesterification—without impacting yield or the throughput rate of the facility (Photaworn et al., 2017). Feedstocks that are low in FFAs, such as refined, bleached, and deodorized (RBD) virgin oils (e.g., RBD soy or RBD canola oil), do not require esterification and can proceed directly to transesterification.

Biodiesel Production (Transesterification)

Transesterification is the principal step of the FAME production process to convert triglycerides to crude FAME or “crude” biodiesel. Transesterification is accomplished through the addition of short-chain alcohol molecules in place of the glycerin backbone of the triglyceride molecule. One triglyceride is combined with methanol to produce three FAME molecules and one glycerin molecule. The reaction can utilize ethanol to produce FAME; however, most refiners use methanol due to its lower cost. Crude FAME (crude biodiesel) is then further refined to remove unreacted feedstock, catalyst, and sterol impurities that can cause fuel filter plugging at low temperatures. The refined biodiesel is ready for use in diesel engines, from light-duty vehicles to large freight transport. Transesterification requires minimal energy input, with temperatures slightly above ambient levels to convert the triglycerides in crude oil

or fat into FAME. The transesterification process begins with the heating of the refined oil or fat, methanol, and catalyst prior to a reaction tank where the reaction proceeds with excess catalyst and methanol for 1 to 2 hours. This process converts approximately 90 percent of the triglyceride feed. Following the first reactor, the effluent is fed to a decanter where heavier glycerin is removed from the biodiesel and unreacted triglyceride feedstock. The transesterification and decanting process is repeated. The twin conversion reactor process typically results in nearly 100 percent conversion of the triglyceride feedstock to biodiesel. Throughout these steps, excess methanol and, to a lesser extent, excess catalyst are added to ensure that the reaction proceeds in the correct direction, but is later collected and reused (CIWC, 2016). The complete transesterification process is illustrated in *Exhibit 7-3*.

EXHIBIT 7-3: Transesterification Flow Diagram

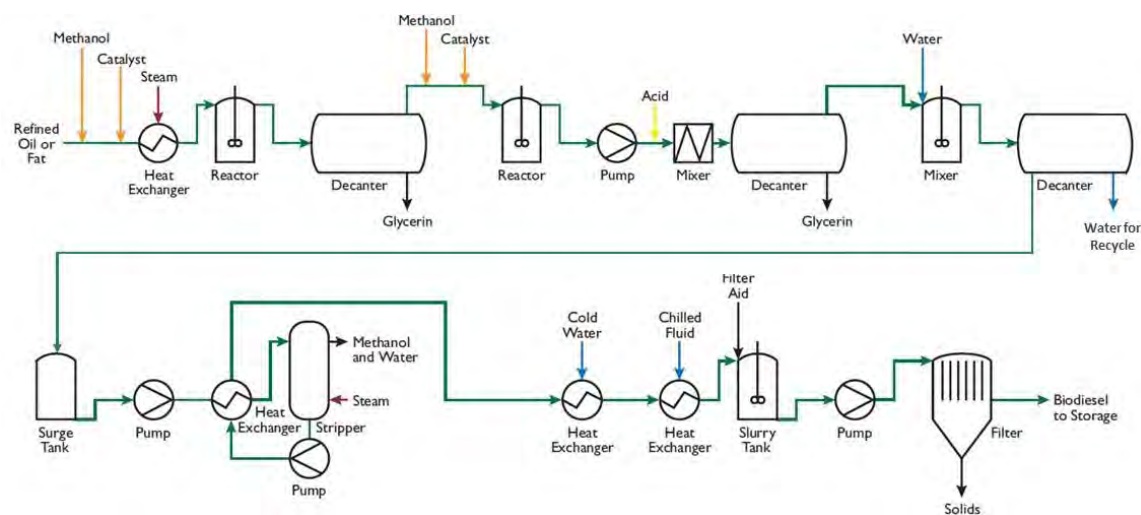

Source: CIWC, 2016.

Refining

Refining, as defined in the U.S. biodiesel sector,²²⁴ refers to the purification process. Most commonly, refining includes the removal of unreacted feedstocks, select contaminants, and sterols. There are two conventional commercial refining techniques currently in use: *wet washing* and *dry washing*. Each of these washing techniques have advantages and disadvantages, which affect the overall yield, quality, and cost of the final biodiesel product (see *exhibit 7-4*) (Atadashi et al., 2011). Following the washing step, most commercial facilities utilize distillation to remove residual sterols that are not removed in the washing process, albeit with 2 percent to 3 percent final product loss in the form of heating oil. Biodiesel refining facilities weigh each of these characteristics when considering the best option for their operation, including feedstock availability, utility costs, water costs, and end-product needs (i.e., cold weather performance). Wet washing followed by distillation is usually the least expensive of the refining options; however, in areas with water or wastewater limitations, dry washing can be the lower cost process.

²²⁴ Asian biodiesel and olefin producers use the term *refining* to refer to the pretreatment process and *distillation* to refer to the purification process.

EXHIBIT 7-4: Comparison of Biodiesel Purification Techniques

Technique	Advantages	Disadvantages
Wet Washing	<ul style="list-style-type: none"> • Superior methanol removal • Reduction of methanol, soap, and free glycerol levels 	<ul style="list-style-type: none"> • Emulsion formation, wastewater treatment, no effect on glycerides • Consumption of water and sodium sulfate (Na_2SO_4), high final product drying cost • Soap and emulsion formation lead to lower yield and higher energy costs
Dry Washing	<ul style="list-style-type: none"> • Adsorbents such as Magnesol® and ion exchange systems can remove free and bonded glycerol, soap, and potassium; can be used to replace water washing • Increased sulfur removal • Can reduce energy requirements and shorten processing time • Reduced water consumption and lower wastewater production 	<ul style="list-style-type: none"> • Generally more expensive than water washing • Methanol must be removed to avoid saturation of the adsorbent • Dry washing process equipment is more complex than water wash equipment

Source: Atadashi et al., 2011.

Renewable Diesel Fuel Production

Renewable diesel differs from biodiesel production in that the final product is not a methyl ester (i.e., it does not contain oxygen) but rather normal paraffins that are chemically identical to fossil diesel. Currently, the main renewable diesel production method is hydrotreating, a conventional petroleum production technology that utilizes hydrogen to remove the oxygen atoms from organic lipids (both triglycerides and FFAs). Hydrotreated renewable diesel is produced from the same feedstocks as biodiesel, but with fewer restrictions in terms of the FFA content. While FFAs negatively impact the yield of the transesterification reaction, the hydrotreating process is unaffected by the presence of FFAs. Hydrotreating FFAs removes the oxygen from the carboxylic acid resulting in fully saturated paraffinic hydrocarbons, which do not experience oxidative deterioration (Yoon, 2011).

While renewable diesel production has distinct capital cost disadvantages at smaller scales (the capital costs for renewable diesel production are approximately three to four times that of biodiesel production) and requires refinery-grade hydrogen, existing petroleum-refining hydrotreating process units can be converted to produce renewable diesel. Because of the larger scales possible with renewable diesel and the efficiencies of leveraging existing refining and hydrogen production infrastructure, several renewable diesel facilities have been constructed as greenfield facilities adjacent to existing refining infrastructure or retrofit into idle or underutilized refineries. The dedicated hydrotreated renewable diesel facilities in the U.S. include the operating Diamond Green Diesel (Valero and Darling) facility in Louisiana; Marathon (formerly Tesoro) facility currently undergoing retrofit in Dickerson, SD; AltAir fuels at the Paramount refinery in California; REG Geismar Biorefinery in Geismar, Louisiana; and East Kansas Agri Energy in Garnett, Kansas. These facilities utilize a combination of scale, leveraging existing infrastructure, GHG reduction programs in California and Oregon, and unlimited blending potential to economically produce renewable diesel.

While there are other production processes that can be used to produce renewable diesel from biomass other than fats and oils, the other processes are typically less commercially mature and/or have cost disadvantages versus the hydrotreating method.

BIODIESEL FEEDSTOCKS

In the United States, biodiesel feedstocks vary by geographic region; however, biodiesel production is overwhelmingly supplied by soybean oil (accounting for more than 50 percent of total feedstocks), followed by corn oil, canola oil, recycled feeds, and animal fats (*exhibit 7-5*). In recent years, the use of distillers corn oil as a biodiesel feedstock has expanded significantly. Ethanol refineries began adopting corn oil recovery technologies in 2012, and the technology has largely been adopted across most ethanol refineries (Schill, 2019). Ethanol plants typically recover 0.8 pounds of corn oil per bushel of corn processed (RFA, 2020).

EXHIBIT 7-5: Feedstock Inputs to U.S. Biodiesel Production, 2018

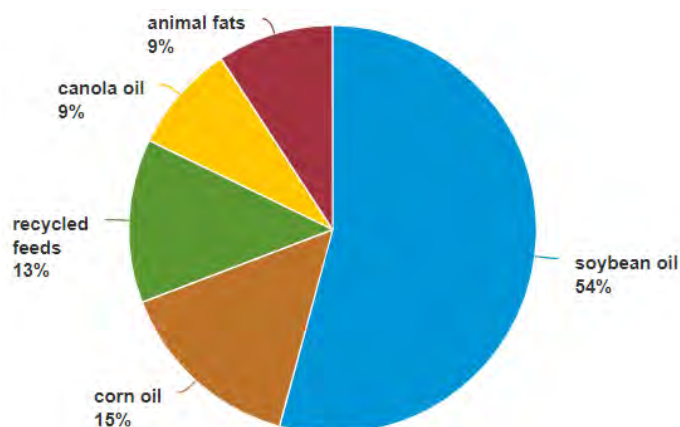

Source: EIA, 2019b.

Biodiesel producers typically size and design their facilities to utilize locally available feedstocks to minimize feedstock acquisition and transport costs. *Exhibit 7-6* illustrates the relationship among soybean production regions (illustrated in green), high protein animal units (orange dots), biodiesel plants (pink dots), transportation infrastructure, and export ports (percentage of export from each region is noted in the yellow boxes). More than half of the U.S. biodiesel capacity is located the Midwest Petroleum Administration for Defense Districts (PADD) 2 region, which overlaps with soybean and corn producing regions (EIA, 2019c). The biodiesel facilities in rural, soybean regions are typically larger in size, while biodiesel facilities in population centers are typically smaller and focus on recycled feeds like used cooking oil.²²⁵

The use of low-carbon intensity feedstocks such as used cooking oil, yellow grease, and byproduct corn oil from ethanol production has increased recently due to the revenues available through the California and Oregon low-carbon fuel programs; however, the availability of these feedstocks is limited, which will constrain production in the near- to medium- term.²²⁶ Yellow grease is a byproduct of animal-processing operations, so production is contingent upon the quantity of meat produced in the country. According to the USDA Economic Research Service (ERS), U.S. beef is projected to increase from approximately 27 billion pounds in 2018 to 29.5 billion pounds in 2029 (USDA, 2020, p. 45). Collection of used cooking oil at restaurants has become universal in populated areas of the United States, so there is limited room for expansion (Wiltsee, 1998, p. 3). The National Renderers Association estimates that 4.4 billion pounds of used cooking oil is collected annually. For reference, one of the largest biodiesel producers, Renewable Energy Group (REG), uses a conversion factor of 8.5 pounds of used cooking oil per gallon of biodiesel (REG, 2020a, p. 33).

²²⁵ Information on biodiesel plant size and location can be found at (Biodiesel Magazine, 2019).

²²⁶ The terms *used cooking oil* and *yellow grease* are used interchangeably by some feedstock suppliers because they share chemical properties; therefore, adjustments need to be made to compare feedstock sourcing metrics from the various reporting agencies.

EXHIBIT 7-6: Overview of Soybean Production, Biodiesel Plant Locations, Soybean Exports, and Transportation Infrastructure in the United States, 2014

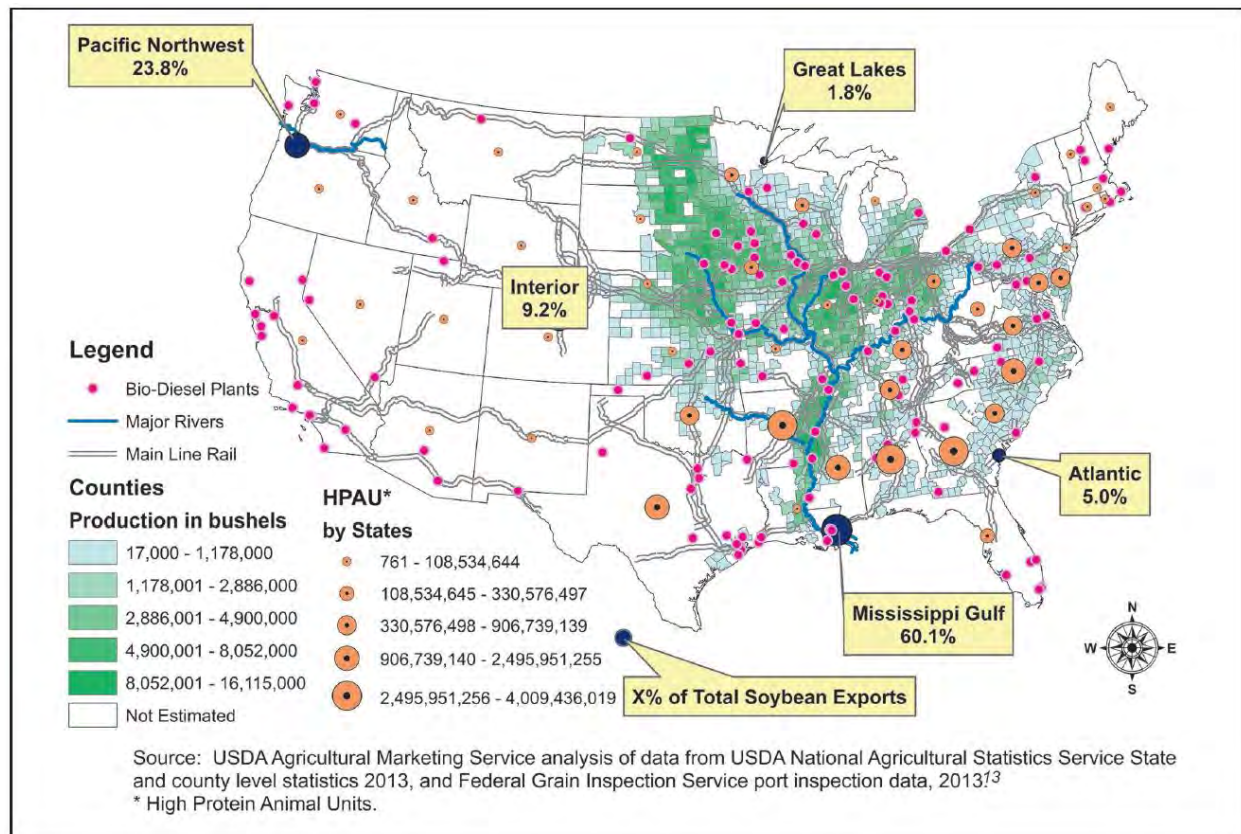

Source: USDA, 2014, p. 6.

Exhibit 7-7 illustrates the gradual increase of total biodiesel feedstocks between 2012 and 2018. Total feedstock inputs for 2018 were approximately 12,500 million pounds, which exceeded the total for 2017 by more than 1,000 million pounds. For the most part, the increase from 2017 to 2018 was due to increases in soybean oil. Soybean oil has remained the highest share of biodiesel feedstock inputs, with an average share of 56 percent from 2012 to 2018, while animal fat from poultry has consistently been the lowest with an average share of 1.6 percent over that time period (EIA, 2019a).

Cottonseed oil represents a minimal contribution due to cost concerns, while palm oil has been effectively shut out of the U.S. market due to the EPA determination that inclusion of indirect land use effects resulted in insufficient GHG reductions to comply with the minimum GHG reduction requirements within the U.S. Renewable Fuel Standard (RFS) (EPA, 2012).

EXHIBIT 7-7: U.S. Biodiesel Feedstock Inputs, 2012–2018

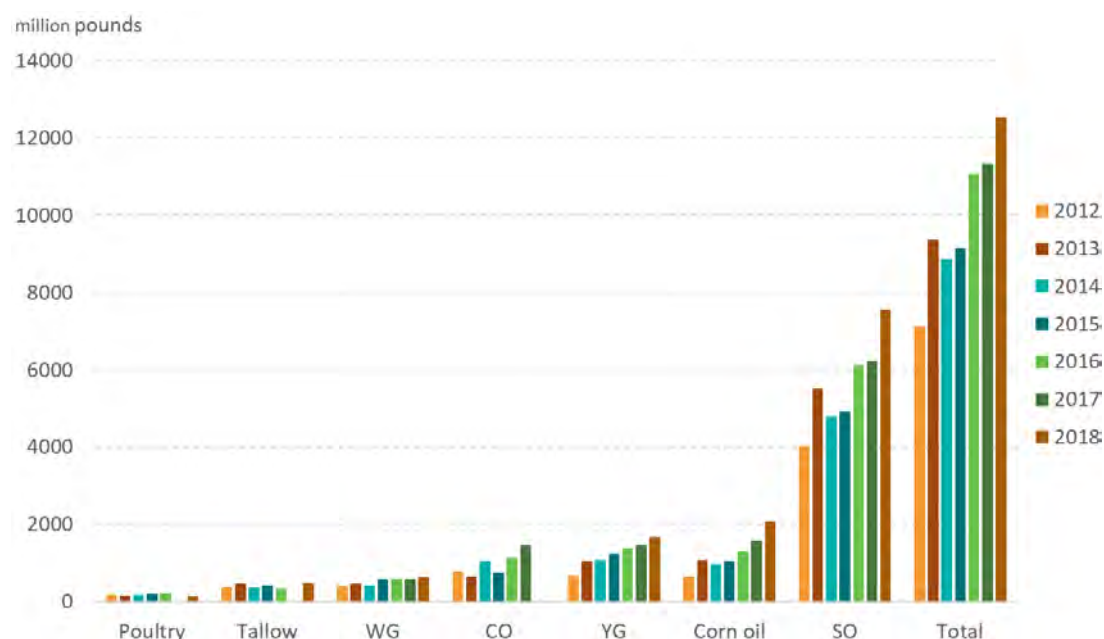

Note: WG: White grease; CO: Canola oil; YG: Yellow grease; SO: Soybean oil

Source: EIA, 2019a.

CURRENT STATE OF ADOPTION AND REGIONAL DISTINCTIONS

The U.S. market for biodiesel and renewable diesel expanded rapidly since the enactment of the RFS program under the Energy Policy Act of 2005 (EPACT 2005). The expansion has become more pronounced since 2010 when the biomass-based diesel category volumetric targets were expanded under the Energy Independence and Security Act of 2007 (which went into effect in 2010). Overall, production of biodiesel increased from 9 million gallons in 2001 to a peak of 1.86 billion gallons in 2018, with a slight decrease in 2019 to 1.7 billion gallons (*exhibit 7-8*). Biomass-based diesel (biodiesel and renewable diesel) capacity in the United States is just over 2.6 billion gallons per year as of 2019 (EIA, 2019c).

U.S. biodiesel consumption has increased steadily but modestly, remaining below 500 million gallons per year between 2001 and 2009. Between 2010 and 2017, a steep increase in consumption resulted in a peak in 2016 of just over 2 billion gallons. Consumption has since declined to just over 1.8 billion gallons in 2019 (*exhibit 7-8*). The United States currently accounts for about 22 percent of global biodiesel consumption, a larger share than any other country (EIA, 2020b). In comparison, Brazil, which consumes the second most biodiesel at 1.0 billion gallons annually, has a 10 percent share of the world total.

The biodiesel production tax credit has historically been an important factor in the profitability of biodiesel and renewable diesel production. While the credit has expired and has been retroactively renewed six times since the inception of the credit in 2005, production at larger facilities has typically continued based on a speculative basis (REG, 2020a, p. 7). Producers received a retroactive extension of the credit through 2017 as part of the 2017 tax reform bill, and as part of the December 2019 Federal budget negotiations, an extension of the tax credit to 2022 (including a retroactive extension through 2018) (Kotrba, 2019). Historically, the biodiesel production tax credit has received bipartisan support (Sapp, 2019).

EXHIBIT 7-8: U.S. Biodiesel Production and Consumption, 2001–2019

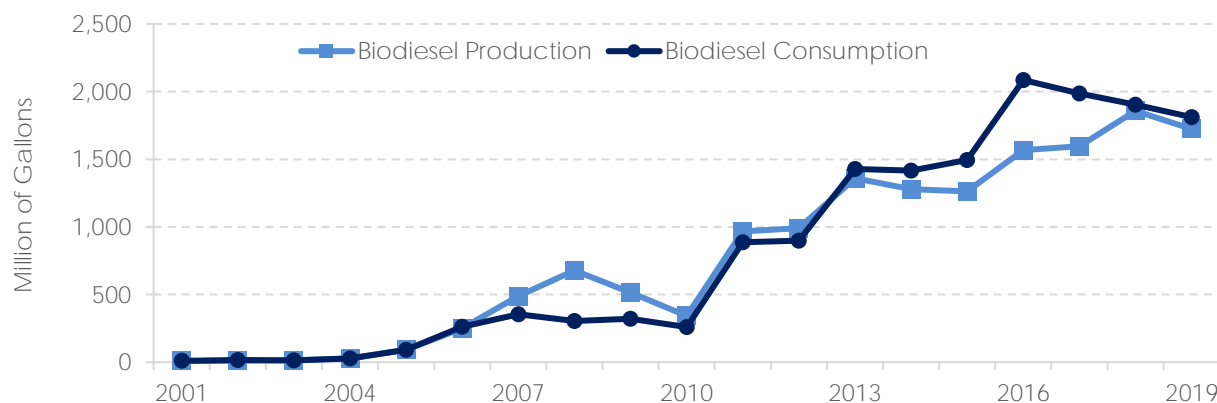

Source: EIA, 2020a, table 10.4.

Exhibit 7-9 shows that biodiesel production capacity is centered in the Midwest. The Midwest has a competitive advantage with respect to feedstock costs (e.g., soybeans, corn oil, animal fats). Soybean prices are lower in rural areas away from population centers, as illustrated by basis maps that document the discount to Chicago Board of Trade (CBOT) market pricing in rural areas versus premiums to CBOT near populated areas (Kansas State University, 2020). Biodiesel is primarily transported to distribution centers across the country by rail or truck. According to the U.S. Energy Information Administration (EIA), biodiesel accounted for approximately 3.6 percent of total U.S. diesel consumption in 2018, and will increase to 4.5 percent in 2020 (EIA, 2019d). U.S.-produced biodiesel is predominantly consumed in the United States (about 93 percent of total production) (EIA, 2020b). The remaining biodiesel is exported, mostly to Canada (88 percent of exports) (EIA, 2019e).

EXHIBIT 7-9: U.S. Biodiesel Production Capacity by Region, 2015–2019

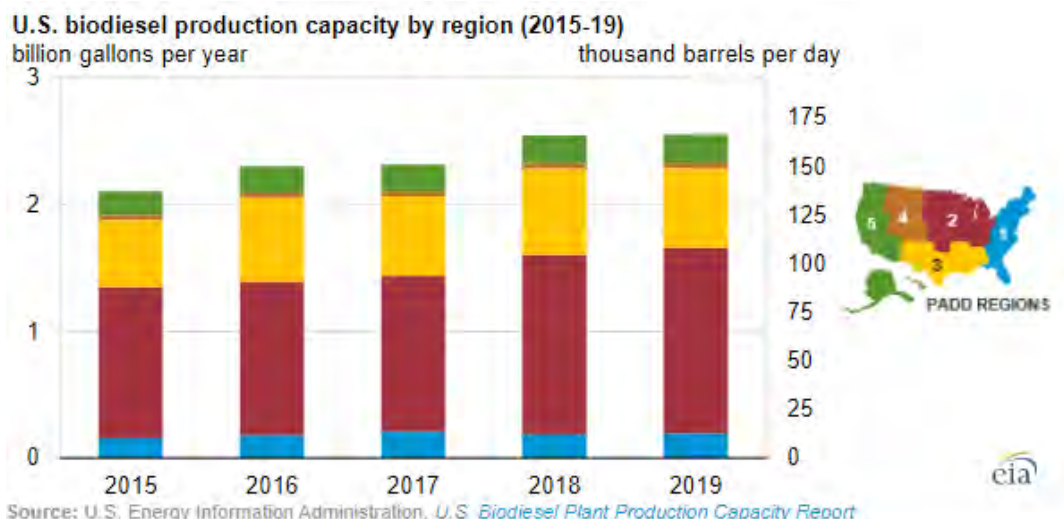

Source: U.S. Energy Information Administration, U.S. Biodiesel Plant Production Capacity Report

Source: EIA, 2019c.

U.S. biodiesel exports to Europe have been severely curtailed due to trade issues. The European Committee for Standardization included a technical requirement within European biodiesel specification EN14214 that limits the iodine number of biodiesel to a maximum of 120 grams of iodine per 100 grams of biodiesel (British Standard, 2010). Technically, the iodine number is a measure of the number of double bonds and oxidative stability of biodiesel. Biodiesel produced from rapeseed oil, the predominant feedstock in Europe, has an iodine number of 94 to 120, while soybean oil has an iodine

number of 120 to 136. European producers have historically noted that the difference is essential to meeting storage and cold weather stability requirements, while U.S. producers have argued that there is not a material performance difference. The Iodine number has been the subject of several disputes at the World Trade Organization and litigation in both the United States and Europe (USDA, 2018).

Production of renewable diesel is a nascent but rapidly growing sector. According to the Alternative Fuels Data Center, total renewable diesel production capacity in 2018 was approximately 356 million gallons, produced from just four commercial facilities. Renewable diesel also is imported into the U.S. market, primarily from Singapore, for use under the California Low Carbon Fuel Standard (LCFS) and the Oregon Clean Fuels Program (OCFP).

As of early 2020, it appears likely that the demand for low-carbon renewable diesel (i.e., made from used cooking oil and corn oil) will continue to grow. In addition to LCFS and OCFP, Puget Sound, Colorado, New York, and a number of Midwest States are considering adopting an LCFS similar to those adopted in California and Oregon (Godwin, 2019; Lane, 2019; Lillian, 2019; New York State Senate, 2019). Additionally, British Columbia has a low-carbon fuel program in place while the Canadian government is in the rulemaking process to implement a nationwide program for liquid renewable fuels by 2022.

ADOPTION COSTS

Total costs associated with the production of biodiesel and renewable diesel are based on the technologies detailed in the previous sections. The literature on biodiesel production costs is more robust and detailed than that for renewable diesel. As a result, biodiesel is the primary focus for this section.

Renewable Diesel

Renewable diesel plants tend to be larger than biodiesel plants. Plant capacity tends to be near or larger than 100 million gallons per year.²²⁷ These larger plants reduce expenses by leveraging economies of scale in production. The largest producer worldwide is Neste, which produces nearly 700 million gallons annually from three separate sites (Finland, Netherlands, and Singapore) (McCormick & Alleman, 2016).

Neste has reported production costs (excluding feedstocks) under \$1/gallon (\$0.56 to \$0.70/gallon) (Loveday, 2011). Valero reports an average of \$1.64/gallon of margin on its renewable diesel production in 2019 (Valero, 2020, p. 17). Existing reports have estimated the costs for renewable diesel from pyrolysis processing at about \$2 per gallon in production (Haq, 2012, p. 6). No commercial renewable diesel refineries from pyrolysis oil have been constructed to date.

Biodiesel

Biodiesel production costs vary based on plant capacity, process efficiencies, feedstock costs, financing structure, and other variables. Production costs, however, are primarily driven by feedstock costs. For soybean oil biodiesel, feedstock can account for more than 80 percent of the total costs for a typical refinery (Irwin, 2019). A model developed by Iowa State University researchers indicates that feedstock accounts for 82 percent of variable costs and 79 percent of total costs, excluding depreciation and interest (Hofstrand, 2019).

²²⁷ For example, the annual capacity of Diamond Green Diesel is 275 million gallons, REG Geismar is 75 million gallons, and Marathon Dickerson is 184 million gallons. World Energy Paramount, which currently has a capacity of 45 million gallons per year, will expand to 306 million gallons per year.

The profitability at biodiesel refineries that use soybean oil as their primary feedstock typically vary seasonally and year to year. *Exhibit 7-10* shows variations in modeled profit margins over time.

Historically, profits have generally increased later in the year (i.e., fourth quarter) as refineries ramp up production to meet RFS compliance deadlines and to take advantage of lower feedstock prices associated with the annual harvest period for soybeans. Variations in profitability are largely driven by changes in soybean prices. For

EXHIBIT 7-10: Variability in Modeled Profit Margins (\$ profit/gallon biodiesel), 2007–2018

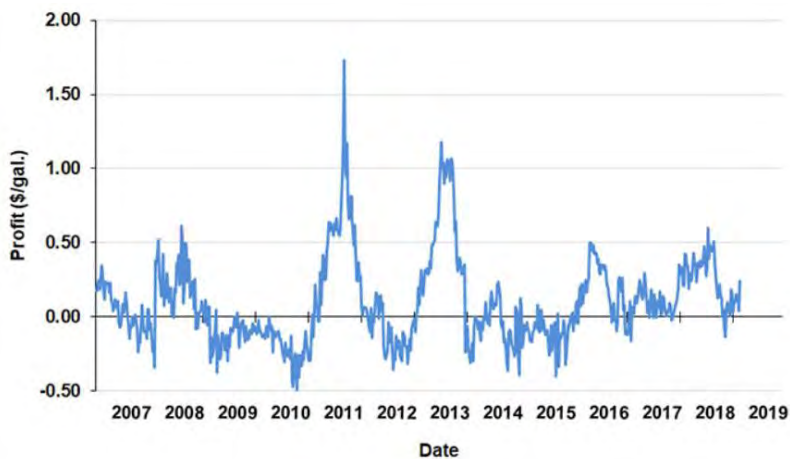

Source: Irwin, 2019.

example, the 2012 drought in the Midwest increased the cost of soybean oil, which resulted in a decrease in profit margins for biodiesel producers (Good, 2013).

Profits for biodiesel plant owners also are generally correlated with the status of the biodiesel production tax credit (Irwin, 2017). From 2005 until the end of 2022, biodiesel and renewable diesel producers have the opportunity to claim a refundable tax credit of \$1.00/gallon under the Biodiesel Production and Blending Tax Credits (DOE, 2019a). Historically, these credits account for more than a third of the representative model revenues. Since the original implementation of the credit in 2005, U.S. Congress has allowed the credit to expire seven times. In each case, Congress later restored the credit and paid producers retroactively for biodiesel produced during the period of expiration (Irwin, 2017; Irwin, 2019).

The remainder of this section presents summarized cost results for a representative soybean oil-fed biodiesel plant based on the Iowa State University model. The representative plant has a nameplate capacity of 30 million gallons, is located in Iowa, was constructed in 2007, and is powered by natural gas and electricity (Hofstrand, 2019). Total and specific component costs associated with producing biodiesel derived using the Iowa State University Biodiesel Profitability Calculator are shown in *Exhibit 7-11*. All costs are presented in terms of dollars per gallon of biodiesel. *Exhibit 7-12*, *Exhibit 7-13*, and *Exhibit 7-14* present more detailed breakdowns of capital, fixed, and other variable costs.

EXHIBIT 7-11: Modeled Production Costs for Biodiesel Production

Period	\$/gallon Biodiesel					Total
	Soybean Oil	Natural Gas	Methanol	Other Variable	Fixed	
5-year average	2.38	0.04	0.13	0.25	0.26	\$3.06
May 2019	2.04	0.04	0.14	0.25	0.26	\$2.73

Source: Hofstrand, 2019.

Capital

Capital costs for constructing a biodiesel facility include site preparation, engineering expenses, permitting, financing, and construction operations. These costs are included within the total installed cost of \$47 million, with the plant operating over an assumed 15-year lifetime. The Iowa State University calculator assumes that the facility is 50 percent financed through a 10-year loan at an 8.25 percent interest rate, which dictates the interest payments (\$0.65/gallon biodiesel). There have been a limited number of biodiesel facilities built in the United States in recent years; however, the costs in the model are generally consistent with the announced costs of biodiesel projects, such as Cargill's new Wichita, KS, \$90 million facility that is to produce 60 million gallons per year of biodiesel (\$1.50 per annual gallon of capacity) (Cargill, 2017).

Operations and Maintenance

Operation and maintenance (O&M) costs for the representative biodiesel production facility include fixed, feedstock inputs, and other (variable and non-fuel) costs.

Fixed and Owners' Expenses

The fixed O&M costs include maintenance materials and services, direct and indirect labor and benefits, operations management, office and lab expenses, training, travel, and professional consulting fees. *Exhibit 7-13* shows these costs on a per gallon of biodiesel basis. Depreciation and interest costs are excluded in *exhibit 7-11*.

Variable Costs

Variable costs, excluding fuel and feedstock costs, represent operational costs that vary with the level of biodiesel production. Non-fuel or feedstock variable costs include methanol, reaction catalyst, reaction acid, miscellaneous process and utility chemicals, transportation, electricity, water, repairs, and maintenance. These costs make up about 10 percent of total production costs (shown as "Other Variable" costs in *Exhibit 7-11*). In the current Iowa State University calculator, feedstock transportation costs account for almost 40 percent of the "Other Variable" costs category. Chemicals and ingredients represent approximately 22 percent. Repairs and electricity each make up 12 percent. *Exhibit 7-14* shows these costs in terms of dollars per gallon of output.

Fuel/Feedstock O&M

Feedstock costs represent the bulk of biodiesel production costs. In the refinery modeled, the May 2019 cost of soybean oil is \$2.04/gallon of biodiesel. Additionally, the plant is heated using natural gas (\$0.04/gallon), and methanol is used in the esterification process (\$0.14/gallon). With soybean oil making up 80 percent of total costs, changes in the market price of biodiesel generally reflect changes in soybean oil prices (with a partial markup for fixed and variable costs) (Irwin, 2019).

EXHIBIT 7-12: Capital Costs From the Representative Model

Capital Cost Component	\$ Millions
Organizational Costs	0.2
Process System	30.0
Land, Site, and Other	7.4
Construction-Related Costs	2.5
Office and Administration	0.9
Inventory & Working Capital	6.0
Total	47.0

Source: Hofstrand, 2019.

EXHIBIT 7-13: Modeled Fixed and Owners' Costs From the Representative Model

Fixed and Owners' Cost Component	\$/gallon
Labor & Management	0.05
Marketing & Procurement	0.04
Property Taxes, Insurance, etc.	0.01
Total	0.10

Source: Hofstrand, 2019.

EXHIBIT 7-14: Modeled Variable Costs From the Representative Model

Variable Cost Category	\$/gallon
Chemicals & Ingredients	0.06
Repairs & Maintenance	0.03
Transportation	0.10
Water	0.01
Electricity	0.03
Other	0.03
Total	0.26

Source: Hofstrand, 2019.

ADOPTION IMPACTS

Beyond its value as a fuel, biodiesel production has an array of potential economic, environmental, and land use impacts. These impacts include the following:

1. Energy security
2. Employment
3. Enhanced engine operation and a reduction in maintenance costs
4. Reduced GHG emissions
5. Potential negative environmental and land use impacts

For several decades, energy security policy in the United States has focused on decreasing the country's dependence on foreign oil. Biofuel production has been largely successful in reducing imports of crude oil to the United States. In every year since 2005, growth in domestic biofuel production has helped to lower total annual net imports of petroleum (EIA, 2019f). Because biodiesel is produced domestically and can either be substituted for, or blended with, conventional diesel, expanding biodiesel production provides energy security to national, State, and local governments by decreasing the need for petroleum imports. In 2018, biomass-based diesel accounted for approximately 3.6 percent of total diesel fuel consumption in the United States (EIA, 2019d). While this accounts for a relatively small share of total U.S. diesel consumption, EIA's 2020 Short-Term Energy Outlook estimates that the share of biomass-based diesel is growing, will continue to rise, and will account for 4.3 percent of diesel consumption by 2021 (EIA, 2020c).

Biodiesel production has significant employment impacts. One study conducted for the National Biodiesel Board in 2019 found that the biodiesel industry supports 61,900 jobs (FTI Consulting, 2018, p. 9).²²⁸ In 2017, the industry consumed more than \$3.4 billion of agricultural feedstocks (e.g., soybean oil, canola oil) and \$0.5 billion of animal fats, waste grease, and waste oil (FTI Consulting, 2018, p. 4). This initial spending by the industry and its supply chain has an economic multiplier effect, which positively impacts other sectors of the economy, including agribusiness, rail and truck services, agricultural equipment manufacturers, and the livestock industry (FTI Consulting, 2018).

Additionally, according to the U.S. Department of Energy (DOE), biodiesel can enhance engine operation by increasing fuel lubricity. Fuels with higher lubricity decrease friction between moving parts and decrease premature engine wear (DOE, n.d.-b). Decreasing wear will benefit consumers by reducing vehicle maintenance costs. While medium- and heavy-duty diesel vehicles are not technically alternative fuel vehicles, almost all can run on biodiesel without engine modification.

Biodiesel and renewable diesel provide a low-carbon, alternative fuel option for the transportation sector. Biomass-based diesel is most applicable as a fuel alternative for medium- and heavy-duty truck and freight transportation. The tailpipe emissions from engines using ultra low sulfur (15 ppm) diesel fuel are comparable to those from biodiesel blends; however, a recent life cycle analysis by Argonne National Laboratory, Purdue University, and USDA found that substituting soy biodiesel for conventional petroleum diesel, achieves a 66-76 percent reduction in GHG emissions (Chen, et al., 2018).²²⁹ This is because the carbon in biodiesel was captured by the soybean plant from the atmosphere, while the carbon within fossil diesel was previously sequestered underground.

There are potential negative environmental and land use impacts associated with growing soybeans for biodiesel (EPA, 2018; EIA, 2019g). These impacts are analogous to those associated with corn ethanol, which are described in Chapter 6, and readers are referred to that discussion. While similar in nature, any negative environmental and land use impacts associated with growing soybeans for biodiesel to date are likely much smaller in magnitude than those associated with growing corn for

²²⁸ This includes employment impacts of the entire biodiesel value chain. The assessment identified 2,300 direct jobs, 34,400 indirect jobs, and 25,200 induced jobs associated with the biodiesel industry.

²²⁹ This percentage does not consider the indirect land use change (ILUC) impacts of increased biofuel production. When the various ILUC cases were considered, researchers found that soy biodiesel could have a 66 percent to 72 percent reduction in overall GHG emissions.

ethanol. First, that is because production of biodiesel occurs on a much smaller scale than production of ethanol. Since 2016, annual production of biodiesel has fluctuated between 1.5 and 2.0 billion gallons (see *EXHIBIT 7-8*) and 46 percent of it has been produced from feedstocks other than soybeans (see *EXHIBIT 7-5*). Second, soybeans are nitrogen fixing plants and so require significantly less applied fertilizer than corn (meaning much less nitrogen leaching and runoff). As with ethanol, the negative land use and environmental impacts associated with growing soybeans for biodiesel would likely increase if production of biodiesel expands significantly in the future.

DOMINANT OWNERSHIP/FINANCING MODEL

Biodiesel refineries and distribution infrastructure in the United States tend to be owned and operated either by large corporations or by small investor groups. ADM, Cargill, and other large grain producers own and operate several large biodiesel production facilities that they use to leverage arbitrage opportunities between vegetable oils and biodiesel (ADM, 2019). Renewable Energy Group, Inc. (REG), the largest biodiesel producer in the United States that focuses solely on the production of biodiesel for its revenues, uses its scale to procure feedstocks at discounted rates and has historically purchased underperforming or distressed assets at favorable purchase prices (REG, 2020b). Valero Energy Corporation has significant investments in biodiesel via its Diamond Green Diesel unit. Outside of the large corporations, there are a number of individually owned biodiesel facilities. Typically, these are locally owned feedstock producers, including vegetable oil, used cooking oil, and animal rendering operations (Svejkovsky, 2014). Due to the volatility of the biodiesel production tax credit, Renewable Identification Number (RIN) values, and the broader fuels market, few of the facilities have conventional project finance debt and are equity owned or have some commercial debt (Biofuels International, 2012).

POLICIES TO ENCOURAGE ADOPTION

Federal and State policies and incentives have played a major role in shaping the growth of the U.S. biodiesel industry over the past several decades, most notably the RFS and biodiesel production and blending tax credits (discussed above) at the Federal level.

Renewable Fuel Standard

Established in 2005 and expanded in 2007, the RFS mandates that U.S. transportation fuels contain an increasing quantity of renewable fuels each year through 2022. The RFS designates renewable fuels as conventional, advanced, or cellulosic biofuel and biomass-based diesel. For a more detailed description of the RFS, refer to the Corn Ethanol chapter (chapter 6).

In order to qualify under the statute and regulations, biomass-based diesel must meet a 50 percent life cycle GHG reduction threshold relative to the 2005 fossil fuel baseline. The current annual volume requirement for biomass-based diesel, which includes both biodiesel and renewable diesel, makes up less than 11 percent of the total RFS volume requirement. The 2019 total volume requirement is set 3 percent higher than the 2018 requirement; however, it is nearly 30 percent lower than the statutory volume standard set forth by the Energy Independence and Security Act of 2007 (EISA 2007) (see the Corn Ethanol chapter, *exhibit 6-12*). EISA did not specify volume targets for 2023 and beyond. These will be set by EPA at a future date under its rule-making process based on the available supply of biofuels during its review process.

Obligated parties under the RFS program are refiners or importers of gasoline or diesel fuel. Obligated parties must obtain credits, called *Renewable Identification Numbers*, or RINs, to comply with EPA-specified *Renewable Volume Obligations* (RVOs) that make up a percentage of the total volume requirements. For a detailed description of RVOs and RINs, see the Corn Ethanol chapter.

RIN prices have fallen considerably since early 2018 due to the small refinery exemptions.²³⁰ RIN prices increased significantly in early 2020 following the Federal 10 Circuit Court of Appeals decision that invalidated the small refinery exemptions granted to the refineries in its jurisdiction (United States Court of Appeals for the 10th Circuit, 2020). The court ruled that the EPA had the authority to extend small-refinery exemptions for those refineries that had exemptions in place but did not have the statutory authority to grant new small refinery exemptions. The decision therefore invalidated the extensions for the refineries in the 10th Circuit jurisdiction because they never had an exemption to extend. One report projected RIN prices to recover in the short term and then gradually decrease over time (FAPRI, 2019, p. 50). *Exhibit 7-15* shows EPA data for RIN trading prices for biomass-based biodiesel (RFS code D4) between 2011 and May 2020.

EXHIBIT 7-15: Biomass-Based Biodiesel (D4) RIN Prices, 2011–2019

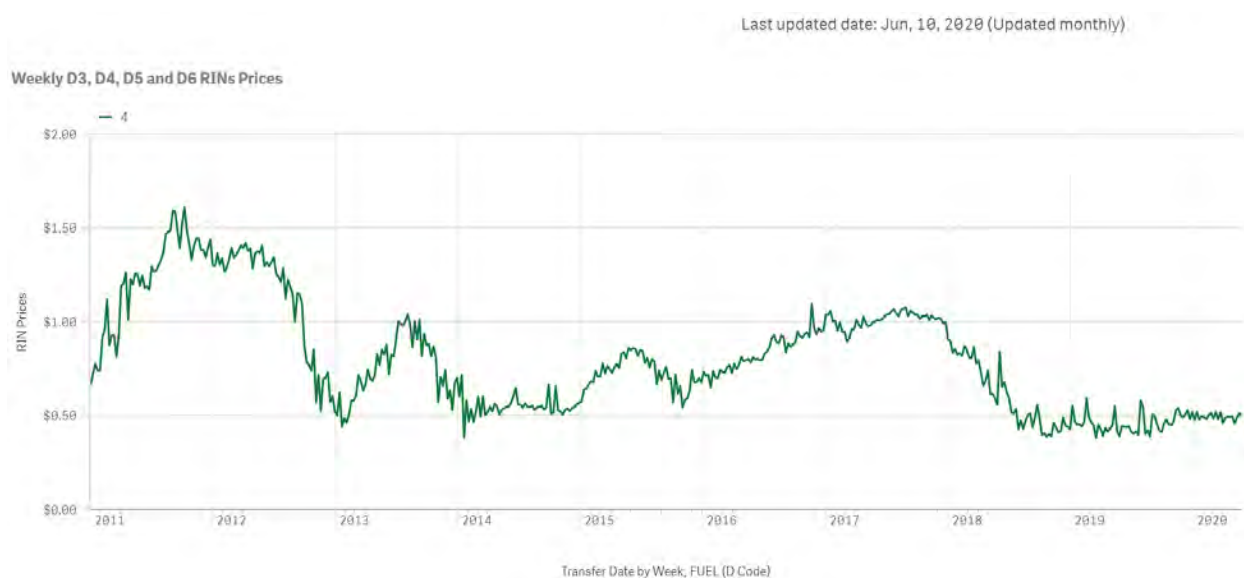

Source: EPA, 2020b.

The RFS appears to have noticeably impacted both U.S. soybean oil production and the share of soybean oil production that is used for biodiesel. As shown in *Exhibit 7-16*, total soybean oil production has increased steadily, while the share of soybean oil used for biodiesel went from about 10 percent in 2010 to 35 percent in 2019.

²³⁰ Under EPA's RFS program, a small refinery may be granted a temporary exemption from its annual RVOs if it can demonstrate that compliance with the RVOs would cause the refinery to suffer disproportionate economic hardship. The definition of *small refinery* is available on the EPA website at <https://www.epa.gov/renewable-fuel-standard-program/renewable-fuel-standard-exemptions-small-refineries>

EXHIBIT 7-16: Total U.S. Soybean Oil Production and Percent Change Used for Biodiesel, 2001–2019

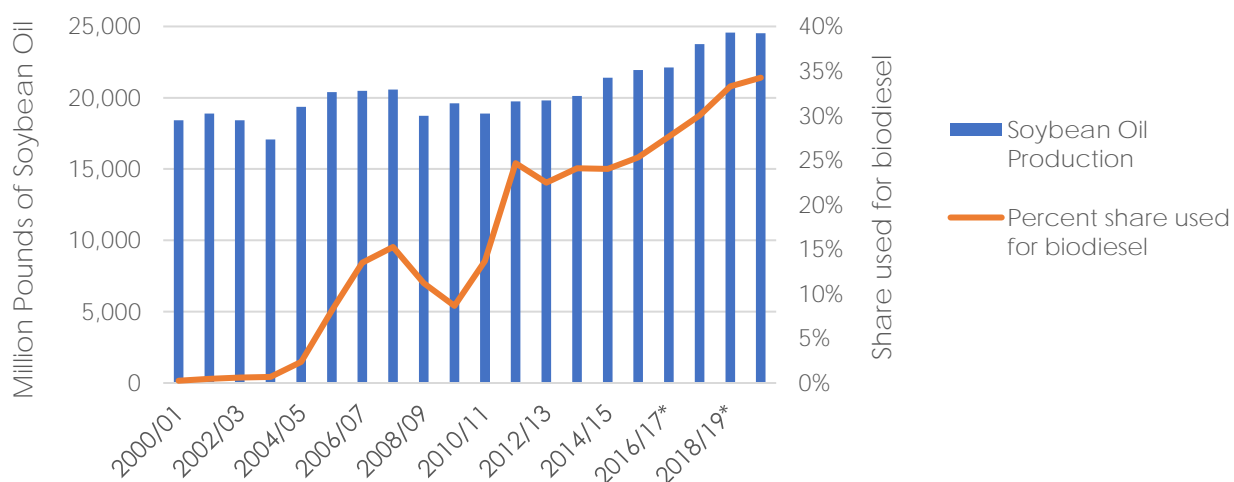

Source: USDA, 2019, table 6.

Other Federal Policies and Incentives

To facilitate the growth of the biodiesel industry, several Federal policies and programs contain financial incentives to help build and maintain the market for biodiesel fuel and vehicles. *Exhibit 7-17* summarizes several national incentive programs that are helping to grow the biodiesel industry.

EXHIBIT 7-17: Federal Financial Incentives for Biodiesel

Federal Incentive Program	Description
Advanced Biofuel Feedstock Incentives	The Biomass Crop Assistance Program (BCAP, section 9010) offers financial support to owners and operators of agricultural land who plan to produce and deliver biomass feedstock crops for advanced biofuel production facilities. Financial assistance comes in two forms: (1) maximum of 50 percent reimbursement for the cost to develop a biomass feedstock crop and annual payments for up to 5 years for herbaceous feedstocks and 15 years for woody feedstocks; and (2) matching payments for the collection, harvest, storage, and delivery of feedstocks to biomass conversion facilities (e.g., E85) for up to 2 years.
Advanced Biofuel Production Grants and Loan Guarantees	The Biorefinery Assistance Program offers loan guarantees up to \$250 million for the development, construction, and retrofitting of commercial-scale biorefinery facilities producing advanced biofuel (e.g., E85). Maximum grant funding is 50 percent of total project costs. Grants for demonstration-scale facilities also are available.
Advanced Biofuel Payment Program	Through this program, producers of advanced biofuels from renewable biomass (other than corn kernel starch) are eligible to receive quarterly payments based on the quantity of biofuel produced and annual incremental payments for producers who increase production from the previous fiscal year.
Advanced Research Projects Agency – Energy	The Advanced Research Projects Agency – Energy (ARPA-E) program is administered by the U.S. DOE and provides funding for research projects that have the potential to radically improve U.S. economic security, national security, and environmental well-being. ARPA-E supports several programs related to transportation fuels and energy conversion.
Improved Energy Technology Loans	Funded by DOE, the Improved Energy Technology Loans Program provides loan guarantees, up to 100 percent of the amount of the loan requested, to support nascent advanced technologies, including biofuels.
Biomass Research and Development Initiative	This program is a collaboration between USDA's National Institute of Food and Agriculture and DOE's Office of Biomass Programs. The Initiative provides grant funding for projects addressing research, development, and demonstration of biofuels and bio-based products and the methods, practices, and technologies for their production.

Federal Incentive Program	Description
Value-Added Producer Grants (VAPGs)	VAPG offers grant and matching funds to independent agricultural producers; farmer and rancher cooperatives; agricultural producer groups; and majority-controlled, producer-based business ventures to support planning activities or capital expenses related to producing and marketing a value-added agricultural product such as biodiesel.
Alternative Fuel Vehicle Conversion and Infrastructure Tax Credit	The Internal Revenue Service provides a 30 percent credit, up to \$30,000, for the cost to install alternative fuel pumps (e.g., E85 fuel pump).

Source: DOE, 2019b.

The national incentive programs currently available are mostly loans, loan guarantees, and project grants. The biodiesel tax credit, which gives producers a \$1.00/gallon tax credit for producing biodiesel or renewable diesel was extended to December 31, 2022, as part of the December 2019 budget negotiations in Congress. This credit, along with the \$0.10 credit for small producers of biodiesel that expired in 2011, are indicated as having greatly influenced the production of U.S. biodiesel as production costs would likely otherwise exceed the retail price for biodiesel (NREL, 2018, p. 32).

State Policies and Incentives

Currently, there are more than 305 active State laws and incentives related to biodiesel (DOE, 2019c). These laws and incentives vary widely; however, several significant policies aim to reduce GHG emissions through a LCFS. Chief among these is California's LCFS. The LCFS allows producers to claim credits for low-carbon fuels that fall below an annual carbon intensity benchmark. Because biodiesel is less carbon intensive than conventional diesel, biodiesel and renewable diesel producers can receive emissions reduction credits based on the difference between the life cycle emissions of the fuels they supply and the carbon intensity standard of petroleum diesel. The carbon intensity of biodiesel varies based on production location, transportation requirements, and feedstock. Using an average low-carbon feedstock such as used cooking oil, biodiesel has a carbon intensity of approximately 25 grams of CO₂ equivalent per megajoule (gCO₂e/MJ). For reference, a gallon of biodiesel contains 126.13 MJ of energy. At the May 2020 LCFS credit trading price of \$205/metric ton of CO₂, this translates to a value of \$1.79/gallon or \$541/metric ton of biodiesel (ANL, 2019; CARB, 2020). Renewable diesel has a similar carbon intensity as biodiesel and earns similar credits when produced from the same feedstock. *Exhibit 7-18* shows the alternative fuel volumes and credit generation by fuel type in the LCFS from 2011 to 2019.

The LCFS has driven higher volumes of biodiesel and renewable diesel. Renewable diesel has seen the largest volume growth of any alternative fuel since 2011 (CARB, 2020). *Exhibit 7-18* also demonstrates the higher value that the LCFS places on fuels with greater GHG reductions. While ethanol makes up the largest amount of alternative fuel on a volume and energy basis, many more LCFS credits were generated by biomass-based diesel fuels due to their lower carbon intensities. Since 2011, the LCFS has reduced the carbon intensity of California's transportation fuel by approximately 4 percent to 5 percent, with the goal of ultimately reaching a 20 percent reduction by 2030.

A summary of State laws and incentives related to biomass-based diesel can be found on DOE's Alternative Fuels Data Center website (DOE, 2019c).

EXHIBIT 7-18: LCFS Alternative Fuel Volumes and Credit Generation, 2011–2019

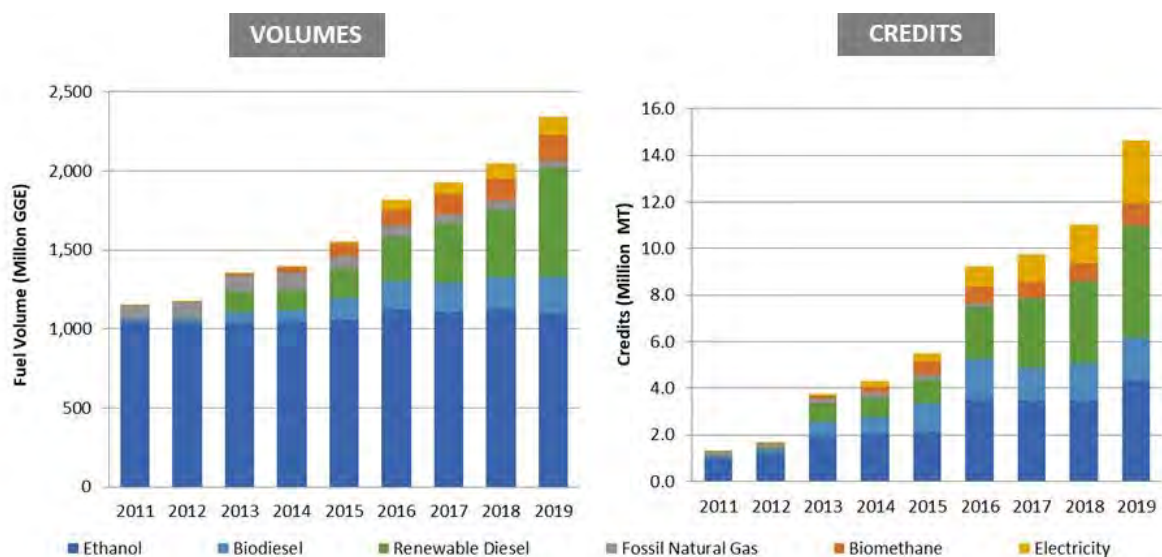

Source: CARB, 2020.

CHALLENGES TO EXTENDING ADOPTION

This section identifies challenges to expanding the market for biodiesel and renewable diesel. The two largest challenges to adoption include infrastructure expansion and end-user demand.

Infrastructure Expansion

Barriers to the expansion of biodiesel and renewable diesel are primarily related to infrastructure compatibility and end use. Retail stations that are interested in selling biodiesel blends above 5 percent must ensure that additional equipment requirements are met. While most existing tanks are compatible with biodiesel blends up to B100, some older tanks and, more generally, equipment at retail stations that move biodiesel from the tank to the vehicle must be upgraded to ensure compatibility with higher blends (DOE, 2020).

Exhibit 7-19 shows the locations of existing biodiesel plants (blue), and alternative fueling stations serving biodiesel blends of B20 and above (in pink). There are currently 621 active biodiesel fueling stations in the United States; however, only 195 (31 percent) are open to the public (DOE, 2019d). Nearly 20 percent of all active biodiesel fueling stations are located in North Carolina; however, more than 90 percent of these stations are private-access service stations used mostly for government or private fleets (EIA, 2018).

EXHIBIT 7-19: Biodiesel Plants and Fueling Stations (B20 and Above)

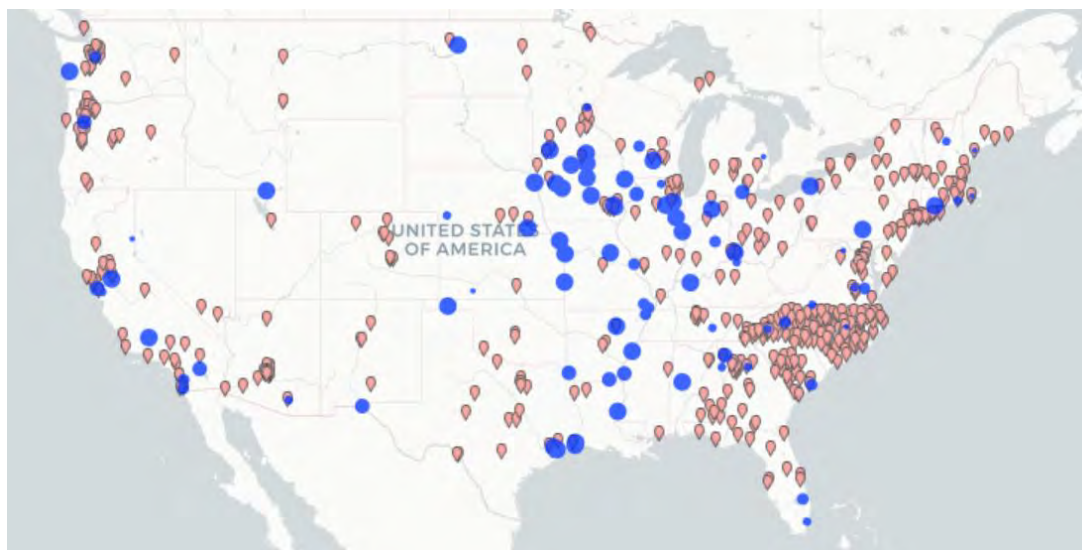

Source: NREL, 2019.

Many of the existing retail stations offering biodiesel are located along major trucking routes. This is because diesel fuel is largely consumed by medium- and heavy-duty trucks and buses as opposed to light-duty vehicles. *Exhibit 7-20* details U.S. transportation energy use by mode and fuel type in 2016. The composition of fuel used by medium- and heavy-duty trucks and buses also contributes to the higher density of stations selling B20 in higher density urban centers and along major highways. The stations outside of these locations are typically private stations serving motor vehicle fleets of the U.S. Department of Defense, other Federal agencies, and local governments (NREL, 2018).

EXHIBIT 7-20: U.S. Transportation Energy Use by Mode and Fuel Type, 2016

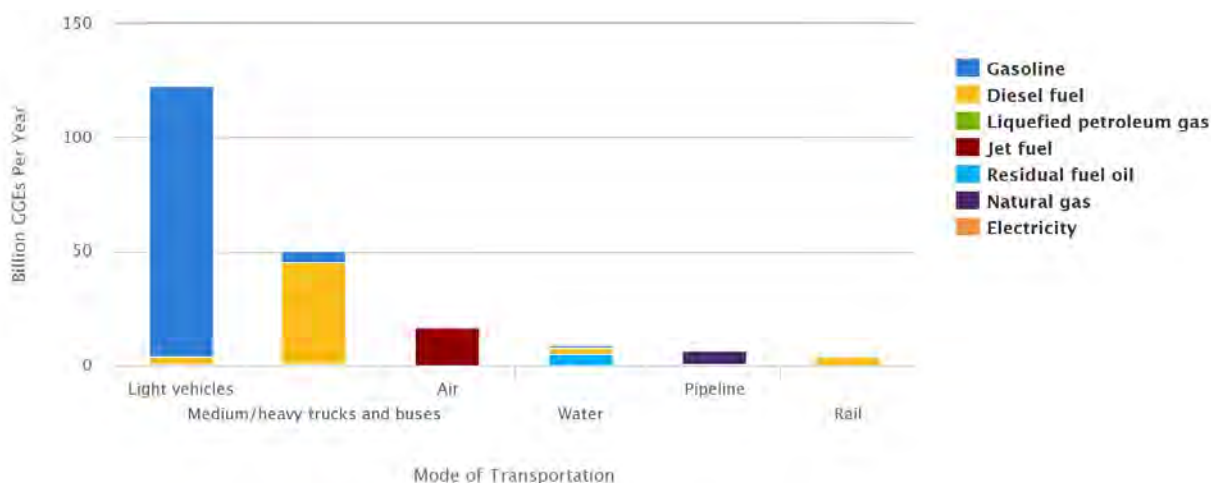

Source: NREL, 2019.

There also are challenges associated with biodiesel storage life and seasonal changeouts between winter and summer diesel. Biodiesel can degrade in 3 to 6 months; however, with proper fuel management, it can be stored for up to 3 years. If biodiesel will be stored for longer than 4 to 5 months, a stability additive is normally used, especially in more southern climates due to increased temperature and humidity (Farm Energy, 2019). Additionally, storage and retail outlets need to switch between summer and winter blends of biodiesel due to performance issues at low temperatures. The Federal Government oversees the codes and standards related to the storage of biodiesel blends. All current

underground storage tank manufacturers have guaranteed that their tanks are compatible with B100; however, many old storage tanks exist that cannot safely store blends above B20 (NREL, 2018).

Progress is being made on the storage of B20 in existing infrastructure. For example, in August 2019, California was the last State to approve the storage of B20 in underground storage tanks (National Biodiesel Board, 2019). However, other restrictions remain for major infrastructure, such as pipelines due to concerns regarding biodiesel's incompatibility with jet fuel (CalEPA, 2018, p. 44).

End Use

There is uncertainty regarding potential technology shifts in the U.S. vehicle market. This includes new demand for battery electric vehicles, as well as compressed natural gas and liquid natural gas vehicles. Sales of light-duty plug-in electric (PEV) and hybrid electric vehicle (HEV) sales have expanded rapidly since 2011. As of 2017, there were more than 340,000 PEVs and HEVs in operation (approximately 280,000 more vehicles than in 2011) (DOE, 2019e).

The demand for biodiesel is heavily reliant on the medium- and heavy-duty trucking industry. This demand appears to be more stable, at least over the next 10 years. There has been a limited shift to electric and natural gas alternative fuels in the medium- and heavy-duty diesel engine market to date, with most detractors referencing range and energy density issues (Kaufmann & Moynihan, 2019). Heavy-truck market analysts indicate that sales of battery electric trucks will be limited in the heavy-duty sector for the foreseeable future due to "cost, range and weight disadvantages when compared to diesel" (IHS Markit, 2018).

REFERENCES

- ADI Analytics. 2020. Regulations to Drive U.S. Renewable Diesel Capacity Growth Through 2025. <https://adi-analytics.com/2020/02/10/regulations-to-drive-u-s-renewable-diesel-capacity-growth-through-2025/> [accessed June 2020].
- ADM. 2019. *2018 Form 10-K*. <https://assets.adm.com/Investors/Shareholder-Reports/2018/ADM-Annual-Report-Letter-to-Stockholders-2019-Proxy-Statement-and-2018-Form-10-K-final-.pdf.PDF> [accessed May 2020].
- ANL, A. N. (2019). GREET Model. <https://greet.es.anl.gov/> [accessed June 2020].
- Atadashi, et al. 2011. Refining technologies for the purification of crude biodiesel. *Applied Energy*: 88 (12), 4239-4251. Atadashi, I., Aroua, M., Abdul Aziz, A., & Sulaiman, N. <https://doi.org/10.1016/j.apenergy.2011.05.029> [accessed June 2020].
- Biodiesel Magazine. 2019. U.S. Biodiesel Plants. Biodiesel Magazine. <http://www.biodieselmagazine.com/plants/listplants/USA/page:1/sort:capacity/direction:desc> [accessed June 2020].
- Biofuels International. 2012. *The project finance market - is it open for biofuels?* Biofuels Finance. <https://cdn2.hubspot.net/hub/14164/file-13246683-pdf/docs/finance.pdf> [accessed June 2020].
- British Standard. 2010. *Automotive fuels - Fatty acid methyl esters (FAME) for diesel engines - Requirements and test methods*. Agrifuels. <http://agrifuelsqcs-i.com/attachments/1598/en14214.pdf> [accessed May 2020].
- CalEPA, 2018. *CalEPA Fuels Guidance Document*. California Environmental Protection Agency. https://ww2.arb.ca.gov/sites/default/files/2018-10/CalEPA_Fuels_Guidance_Document_10-2-18.pdf [accessed June 2020].
- CARB. 2020. Low Carbon Fuel Standard - Data Dashboard. California Air Resources Board. <https://ww3.arb.ca.gov/fuels/lcfs/dashboard/dashboard.htm> [accessed June 2020].
- Cargill. 2017. Cargill to build state-of-the-art biodiesel plant in Wichita, Kansas. <https://www.cargill.com/2017/cargill-to-build-state-of-the-art-biodiesel-plant-in-wichita-ks> [accessed July 2019].
- Cascone, R., & Slome, S. 2019. FAME is fleeting: FAEE as a more sustainable option for biodiesel in the US. *Biofuels Digest*. <https://www.biofuelsdigest.com/bdigest/2019/08/13/fame-is-fleeting-faee-as-a-more-sustainable-option-for-biodiesel-in-the-us> [accessed June 2020].
- Chen et al. 2018. Life cycle energy and greenhouse gas emission effects of biodiesel in the United States with induced land use change impacts. *Bioresource Technology*, 251, 249-258. Chen, R., Qin, Z., Han, J., Wang, M., Taheripour, F., Tyner, W., . . . Duffield, J. <https://www.sciencedirect.com/science/article/pii/S0960852417321648?via%3Dihub> [accessed July 2019].
- CIWC. 2016. *Biodiesel*. Crown Iron Works Company. <http://www.crowniron.com/wp-content/uploads/2018/01/BiodieselMain.pdf> [accessed August 2019].
- Costello, R.C. 2018. Esterification - Biodiesel Part 3. <https://rccostello.com/wordpress/biodiesel/esterification-biodiesel-part-3/> [accessed August 2019].
- DOE. 2016. *2016 Billion-Ton Report – Advancing Domestic Resources for a Thriving Bioeconomy*. U.S. Department of Energy. https://www.energy.gov/sites/prod/files/2016/12/f34/2016_billion_ton_report_12.2.16_0.pdf. [accessed August 2019].
- DOE. 2019a. Expired, Repealed, and Archived Incentives and Laws. Alternative Fuels Data Center. <https://afdc.energy.gov/laws/5831> [accessed June 2020].
- DOE. 2019b. Biodiesel Law and Incentives in Federal. Alternative Fuels Data Center. <https://afdc.energy.gov/fuels/laws/BIOD?state=US> [accessed June 2020].
- DOE. 2019c. Federal and State Laws and Incentives. Alternative Fuels Data Center. <https://afdc.energy.gov/laws> [accessed August 2019].
- DOE. 2019d. Biodiesel Fueling Station Locations. Alternative Fuels Data Center. https://afdc.energy.gov/fuels/biodiesel_locations.html#/find/nearest?fuel=BD [accessed August 2019].
- DOE. 2019e. Maps and Data: Vehicles. Alternative Fuels Data Center. <https://afdc.energy.gov/data/10581> [accessed June 2020].
- DOE. 2020. Biodiesel Equipment Options. Alternative Fuels Data Center. https://afdc.energy.gov/fuels/biodiesel equip_options.html [accessed May 2020].
- DOE. (n.d.-a). Renewable Hydrocarbon Biofuels. Alternative Fuels Data Center. https://afdc.energy.gov/fuels/emerging_hydrocarbon.html [accessed May 2020].

- DOE. (n.d.-b). Diesel Fuels Using Biodiesel. Alternative Fuels Data Center. <https://afdc.energy.gov/vehicles/diesel.html> [accessed May 2020].
- EIA. 2018. North Carolina State Energy Profile. U.S. Energy Information Administration, DOE. <https://www.eia.gov/state/print.php?sid=NC#84> [accessed June 2020].
- EIA. 2019a. Monthly Biodiesel Production Report. U.S. Energy Information Administration, DOE. <https://www.eia.gov/biofuels/biodiesel/production/> [accessed June 2020].
- EIA. 2019b. Biodiesel. U.S. Energy Information Administration, DOE. <https://www.eia.gov/energyexplained/biofuels/biodiesel-in-depth.php> [accessed June 2020].
- EIA. 2019c. EIA releases plant-level U.S. biodiesel production capacity data. U.S. Energy Information Administration, DOE. <https://www.eia.gov/todayinenergy/detail.php?id=41314> [accessed August 2019].
- EIA. 2019d. EIA expects stable U.S. biofuels production, consumption, and trade through 2020. U.S. Energy Information Administration, DOE. <https://www.eia.gov/todayinenergy/detail.php?id=38532> [accessed August 2019].
- EIA. 2019e. Petroleum & Other Liquids – Exports by Destination. U.S. Energy Information Administration, DOE. https://www.eia.gov/dnav/pet/pet_move_expc_a_EPOORDB_EEX_mbb1_a.htm [accessed June 2020].
- EIA. 2019f. Oil: Crude and Petroleum Products Explained - Oil Imports and Exports. U.S. Energy Information Administration, DOE. https://www.eia.gov/energyexplained/index.php?page=oil_imports [accessed August 2019].
- EIA. 2019g. Biomass Explained: Biomass and the Environment. U.S. Energy Information Administration, DOE. <https://www.eia.gov/energyexplained/biomass/biomass-and-the-environment.php#:~:text=Energy%20Information%20Administration%20-%20EIA%20-%20Official%20Energy,impacts%20of%20producing%20and%20using%20biomass%20for%20energy> [accessed August 2020].
- EIA. 2020a. Monthly Energy Review. U.S. Energy Information Administration, DOE. <https://www.eia.gov/totalenergy/data/monthly/#renewable> [accessed July 2019].
- EIA. 2020b. Biofuels Explained: Use of Biodiesel. U.S. Energy Information Administration, DOE. <https://www.eia.gov/energyexplained/biofuels/use-of-biodiesel.php> [accessed June 2020].
- EIA. 2020c. Short-Term Energy Outlook Data Browser. U.S. Energy Information Administration, DOE. <https://www.eia.gov/outlooks/steo/data/browser/#/?v=3&f=A&s=0g> [accessed July 2019].
- EPA. 2012. Notice of Data Availability Concerning Renewable Fuels Produced from Palm Oil Under the RFS Program. Federal Register/ <https://www.federalregister.gov/documents/2012/01/27/2012-1784/notice-of-data-availability-concerning-renewable-fuels-produced-from-palm-oil-under-the-rfs-program> [accessed June 2020].
- EPA. 2018. *Biofuels and the Environment: The Second Triennial Report to Congress*. U.S. Environmental Protection Agency. https://cfpub.epa.gov/si/si_public_record_report.cfm?Lab=IO&dirEntryId=341491 [accessed August 2020].
- EPA. 2020a. *Inventory of U.S. Greenhouse Gas Emissions and Sinks: 1990-2018*. U.S. Environmental Protection Agency. <https://www.epa.gov/sites/production/files/2019-04/documents/us-ghg-inventory-2019-main-text.pdf> [accessed April 2020].
- EPA. 2020b. RIN Trades and Price Information. U.S. Environmental Protection Agency. <https://www.epa.gov/fuels-registration-reporting-and-compliance-help/rin-trades-and-price-information> [accessed May 2020].
- FAPRI. 2019. *U.S. Baseline Outlook: Projections for Agricultural and Biofuel Markets (FAPRI-MU Report #01-19)*. University of Missouri. <https://www.fapri.missouri.edu/wp-content/uploads/2019/04/2019-US-Baseline-Outlook.pdf> [accessed June 2020].
- Farm Energy. 2019. Transportation and Storage of Biodiesel. eXtension Farm Energy. <https://farm-energy.extension.org/transportation-and-storage-of-biodiesel/#:~:text=If%20biodiesel%20will%20be%20stored,to%20increased%20temperature%20and%20humidity.> [accessed June 2020].
- Firdaus, M. Y. 2014. Comparison of Fatty Acid Methyl and Ethyl Esters as Biodiesel Base Stock: A Review on Processing and Production Requirements. *Journal of the American Oil Chemists' Society*, 525-531.
- FTI Consulting. 2018. *The Biodiesel Industry: Impacts on the Economy, Environment and Energy Security*. https://www.fticonsulting.com/~/_media/Files/us-files/insights/reports/biodiesel-industry-impacts-economy-environment-energy-security.pdf [accessed June 2020].
- Gerpen, J. 2005. *Biodiesel processing and production*. *Fuel Processing Technology*. 86(10), 1097-1107.
- Godwin, J. 2019. Groups Exploring Potential Midwest LCFS Collaborative. Governors' Biofuels Coalition <https://www.governorsbiofuelscoalition.org/groups-exploring-potential-midwest-lcfs-collaborative/> [accessed July 2019].
- Good, D. 2013. Corn and Soybean Prices Continue to Retrace 2012 Drought Rally. *farmdoc daily*, 3, 96. Department of Agricultural and Consumer Economics, University of Illinois at Urbana-Champaign.

- <https://farmdocdaily.illinois.edu/2013/05/corn-soybean-prices-retrace-2012-rally.html#:~:text=Corn%20and%20Soybean%20Prices%20Continue%20to%20Retrace%202012%20Drought%20Rally,-Darrel%20Good&text=Corn%20and%20soybean%20prices%20rallied,as%20U.S.%20drought%20conditions%20unfolded.&text=That%20contract%20is%20currently%20trading,above%20the%20pre%2Ddrought%20level.> [accessed June 2020].
- Haq, Z. 2012. *Advanced Biofuels Cost of Production*. U.S. Department of Energy. https://www.energy.gov/sites/prod/files/2014/03/f14/aviation_biofuels_haq.pdf [accessed August 2019].
- Hofstrand, D. 2019. Biodiesel Profitability. Iowa State University. <https://www.extension.iastate.edu/agdm/energy/html/d1-15.html> [accessed May 2020].
- IHS Markit. 2018. *Reinventing the Truck - Analyzing the impact of electrification, alternative fuels, and autonomy advances on fleets, OEMs and suppliers*. <https://cdn.ihs.com/www/pdf/RTT-Whitepaper.pdf> [accessed June 2020].
- Irwin, S. 2017. *Blender and Producer Sharing of Retroactively Reinstated Biodiesel Tax Credits: Time for a Change?* Department of Agricultural and Consumer Economics, University of Illinois at Urbana-Champaign. *farmdoc daily*, 7, 62. <https://farmdocdaily.illinois.edu/2017/04/blender-and-producer-sharing-retroactively.html> [accessed July 2019].
- Irwin, S. 2019. *Biodiesel Production Profitability in 2018: Did Headwinds or Tailwinds Dominate?* *farmdoc daily*, 9, 54. Department of Agricultural and Consumer Economics, University of Illinois at Urbana-Champaign. <https://farmdocdaily.illinois.edu/2019/03/biodiesel-production-profitability-in-2018-did-headwinds-or-tailwinds-dominate.html> [accessed June 2020].
- Kansas State University. 2020. Grain Marketing. AgManager. <https://www.agmanager.info/grain-marketing/grain-basis-maps> [accessed June 2020].
- Kaufmann, J., & Moynihan, R. 2019. Electric trucks like the Tesla Semi are 'pointless both economically and ecologically,' according to a vehicle-tech expert. Business Insider. <https://www.businessinsider.com/this-expert-says-tesla-semi-is-economically-and-ecologically-pointless-2019-2> [accessed June 2020].
- Knothe, G. 2010. *Biodiesel and renewable diesel: A comparison*. *Progress in Energy and Combustion Science*, 36(3), 364-373.
- Kotrba, R. 2019. Historic 5-year extension of biodiesel tax credit signed into law. *Biodiesel Magazine*. <http://biodieselmagazine.com/articles/2516870/historic-5-year-extension-of-biodiesel-tax-credit-signed-into-law> [accessed May 2020].
- Lane, J. 2019. Puget Sound unveils new regional Low Carbon Fuel Standard. *Biofuels Digest*. <https://www.biofuelsdigest.com/bdigest/2019/10/16/puget-sound-unveils-new-regional-low-carbon-fuel-standard/> [accessed May 2020].
- Lillian, B. 2019. Colorado Looks into Establishing Low Carbon Fuel Standard. *Next-Gen Transportation News*. <https://ngtnews.com/colorado-looks-into-establishing-carbon-fuel-standard> [accessed May 2020].
- Loveday, E. 2011. World's largest renewable diesel refiner says cost of fuel is way more than anticipated. *AutoBlog*. <https://www.autoblog.com/2011/09/28/worlds-largest-renewable-diesel-refiner-says-cost-of-fuel-is-wa/> [accessed August 2019].
- McCormick, R., & Alleman, T. 2016. *Renewable Diesel Fuel*. National Renewable Energy Laboratory. https://cleancities.energy.gov/files/u/news_events/document/document_url/182/McCormick___Alleman_RD_Overview_2016_07_18.pdf [accessed August 2019].
- National Biodiesel Board. (n.d.). The Biodiesel Standard (ASTM D 6751). *Biodiesel*. <https://www.biodiesel.org/using-biodiesel/oem-information> [accessed June 2020].
- National Biodiesel Board. 2019. California Approves B20 Biodiesel in Underground Storage Tanks. *Biodiesel*. <https://www.biodiesel.org/news-resources/biodiesel-news/2019/08/25/California-Approves-B20-Biodiesel-in-Underground-Storage-Tanks> [accessed June 2020].
- New York State Senate. 2019. Senate Bill S4003A. <https://www.nysenate.gov/legislation/bills/2019/s4003/amendment/a> [accessed June 2020].
- NREL. 2018. *2016 Bioenergy Industry Status*. National Renewable Energy Laboratory. https://afdc.energy.gov/files/u/publication/2016_bioenergy_status_rpt.pdf [accessed June 2020].
- NREL. 2019. The Biofuels Atlas. National Renewable Energy Laboratory. https://maps.nrel.gov/biofuels-atlas/?aL=b_Fr2K%255Bv%255D%3Dt%26Axnsht%255Bv%255D%3Dt%26Axnsht%255Bd%255D%3D1&bL=clight&cE=0&IR=b_Fr2K.1%255Ba%255D%3Df&mC=39.232253141714885%2C-95.185546875&zL=4 [accessed June 2020].
- Photaworn, et al. 2017. Process development of two-step esterification plus catalyst solution recycling on waste vegetable oil possessing high free fatty acid. (M. O. Coppens, Ed.) *Chemical Engineering and Processing: Process Intensification*, 118, 1-8. Photaworn, S., Tongurai, C., & Kungsanunt, S. <https://www.sciencedirect.com/journal/chemical-engineering-and-processing-process-intensification/vol/118/suppl/C> [accessed August 2019].

- REG. 2020a. *Annual report pursuant to Section 13 and 15(d)*. Renewable Energy Group. <https://investor.regi.com/sec-filings/annual-reports/content/0001628280-20-003141/0001628280-20-003141.pdf> [accessed June 2020].
- REG. 2020b. *Growing our Company and the Biodiesel Industry*. Renewable Energy Group. <https://www.regi.com/about/company/history> [accessed June 2020].
- RFA. 2020. *Ethanol Co-Products*. Renewable Fuels Association. <https://ethanolrfa.org/co-products/> [accessed June 2020].
- Sapp, M. 2019. *More than 20 congress members sign letter urging immediate biodiesel tax credit extension*. Biofuels Digest. <https://www.biofuelsdigest.com/bdigest/2019/06/10/more-than-20-congress-members-sign-letter-urging-immediate-biodiesel-tax-credit-extension/> [accessed August 2019].
- Schill, S. R. 2019. *Pounds That Pay*. Ethanol Producer Magazine. <http://www.ethanolproducer.com/articles/16690/pounds-that-pay> [accessed May 2020].
- State of California. 2020. *State Water Board - Underground Storage Tank Biodiesel Regulations*. California Water Boards. https://www.waterboards.ca.gov/water_issues/programs/ust/adm_notices/bio_regs/ [accessed June 2020].
- Svejkovsky, C. 2014. *Locally Owned Renewable Energy Facilities*. ATTRA Sustainable Agriculture. <https://attra.ncat.org/viewhtml/?id=314#ref> [accessed June 2020].
- United States Court of Appeals for the 10th Circuit. 2020. *Renewable Fuels Association v. EPA*. <https://www.ca10.uscourts.gov/opinions/18/18-9533.pdf> [accessed June 2020].
- USDA. 2014. *Soybean Transportation Profile*. U.S. Department of Agriculture. <https://www.ams.usda.gov/sites/default/files/media/Soybean%20Transportation%20Profile.pdf> [accessed July 2019].
- USDA. 2018. *EU Biofuels Annual 2018*. U.S. Department of Agriculture. https://apps.fas.usda.gov/newgainapi/api/report/downloadreportbyfilename?filename=Biofuels%20Annual_The%20Hague_EU-28_7-3-2018.pdf [accessed June 2020].
- USDA. 2019. *U.S. Bioenergy Statistics*. U.S. Department of Agriculture. <https://www.ers.usda.gov/data-products/us-bioenergy-statistics/us-bioenergy-statistics/> [accessed May 2020].
- USDA. 2020. *USDA Agricultural Projections to 2029*. U.S. Department of Agriculture. <https://www.ers.usda.gov/webdocs/outlooks/95912/oce-2020-1.pdf?v=52.8> [accessed June 2020].
- Valero. 2020. *Basics of Renewable Diesel*. Valero. <http://www.investorvalero.com/static-files/0d76f91b-1de3-400d-8af6-a8f6aebb3327> [accessed June 2020].
- Wiltsee, G. 1998. *Urban Waste Grease Resource Assessment*. National Renewable Energy Laboratory. <https://www.nrel.gov/docs/fy99osti/26141.pdf> [accessed August 2019].
- Yoon, J. J. 2011. *What's the Difference between Biodiesel and Renewable (Green) Diesel*. Advanced Biofuels USA. https://advancedbiofuelsusa.info/wp-content/uploads/2011/03/11-0307-Biodiesel-vs-Renewable_Final-3_-JJY-formatting-FINAL.pdf [accessed August 2019].

8. Agriculture and Forestry Energy Crops

INTRODUCTION

This chapter discusses the potential application of the short-rotation woody crops poplar and shrub willow,²³¹ and purpose-grown grasses Miscanthus and switchgrass as renewable energy resources. While woody biomass and other agricultural wastes (e.g., corn stover [corn stalks, leaves, and cobs], wheat straw, rice husks, and other crop residues) may be used as renewable energy resources, they are byproducts of other activities and not grown specifically for this purpose, and, consequently, not addressed in this chapter. Rather, this chapter focuses on plants that are “purpose-grown” as feedstocks to generate renewable energy.^{232,233} While the energy crops discussed in this chapter play a relatively minor role in current bioenergy production, their roles are much more prominent in long-run visions of the United States moving to a bioeconomy (DOE, 2016a; USGOV, 2016; Scarlet et al., 2015). For this reason, and for completeness, we include them as a chapter in this report.

Globally, wood and grasses have been used as energy feedstocks for heat, light, and cooking for centuries. In the United States, grasses have been used as an energy source since the late 1880s, when they were called “prairie coal” and burned in prairie regions with low access to wood (Biomass Center, 2017). In the past, however, grasses and wood were not purposely grown as renewable energy resources, and the technologies for processing these crops to generate fuel and electricity have been developed relatively recently (Jackson, 2018, pp. 66-67).

Both poplar and shrub willow have traits that make them good candidates for woody biomass production, including fast growth/regrowth and the ability to grow in a wide range of areas in the United States. However, short-rotation woody crops are currently only used in niche markets with few purpose-grown acres due to lack of infrastructure, high harvesting costs, and high start-up costs that result in high breakeven values (Chudy, 2019, pp. 114–124; USDA, 2019a; Kells & Swinton, 2014, pp. 397–406). Similarly, both Miscanthus and switchgrasses have traits that make them excellent candidates for fuel feedstocks; however, high production costs and lack of source-specific infrastructure and markets have resulted in them only being used in niche bioenergy markets (EIA, 2019a; USDA, 2017, p. 1; Brancourt-Hulmel, 2014).

Recent production and use data demonstrate how small these markets are:

- Based on the U.S. Department of Agriculture's (USDA) Census of Agriculture data, approximately 1,200 acres of willow and between 300 and 640 acres of hybrid poplar were in commercial production for bioenergy production in 2016 (USDA, 2019c; Volk et al., 2018, p. 2). The U.S. Department of Energy's (DOE) Billion-Ton Report estimated that 2,554 acres of hybrid poplar were in production in 2014 (DOE, 2016b, p. 28).
- With respect to the grasses, about 5,400 acres of Miscanthus and about 1,000 acres of switchgrass were grown in 2017 (USDA, 2019i; USDA, 2019j).

These production totals may be compared with approximately 37 million acres of corn used for ethanol and 21 million acres of soy grown for biodiesel during the same period (USDA, 2019b; USDA, 2019c; USDA, 2019d; Volk et al., 2018).²³⁴

²³¹ Short-rotation woody crops are tree species that have been bred and selected to have extremely high rates of growth, allowing them to be harvested after a short growing period (Genera, 2020).

²³² “Purpose-grown” feedstocks are plants that are grown with the sole purpose of generating renewable energy. Corn and soybeans are not considered purpose-grown feedstocks as they are also grown for animal feed, food, and other purposes.

²³³ “Woody biomass” is defined as “the by-product of management, restoration, and hazardous fuel reduction treatments, as well as the product of natural disasters, including trees and woody plants (limbs, tops, needles, leaves, and other woody parts, grown in a forest, woodland, or rangeland environment)” (USDA, 2020a).

²³⁴ Corn and soybean acreage were calculated by multiplying total acres grown by the percentage used for corn ethanol (95 million acres x 40 percent) and soybean biodiesel (85 million x 25 percent) (USDA, 2019b; USDA, 2019c; USDA, 2019d; Volk et al., 2018).

In 2018, about 2 percent of total U.S. annual energy consumption was from wood and wood waste (EIA, 2019b).²³⁵ This energy consumption is equivalent to approximately 1.6 million acres of timberland.²³⁶ Of this, an estimated 150,000 acres of production from timberland were used for renewable power generation. Similarly, Miscanthus and switchgrass currently make up a negligible portion of the U.S. biomass energy portfolio, with 6,246 tons of switchgrass and 41,557 tons of Miscanthus harvested in 2017 (USDA, 2019i; USDA, 2019j). These figures may be compared to an estimated 665 million tons of coal consumed in 2017, of which approximately 93 percent (618 million tons) was used for electricity production²³⁷ (EIA, 2019a; USDA, 2017; DOE, 2016b; Brancourt-Hulmel, 2014).

The six most important themes about agriculture and forestry energy crops for the U.S. agricultural and forestry sectors are the following:

1. Nationwide, production of short-rotation woody crops and purpose-grown grasses has been limited in past years; however, increased interest in low and zero net carbon energy resources and feedstocks for biofuels has prompted added interest in these as renewable energy feedstocks.
2. Short-rotation woody crops and purpose-grown grasses for use as energy crops can be grown in many areas of the United States on marginal lands and in poor soils, including idle, retired, and low-productivity cropland.
3. Once planted, energy crops typically require minimal inputs (i.e., added nutrients) and little maintenance.
4. Harvesting can be scheduled to fit in with other crop harvesting schedules. Poplar and willow can be harvested and stored whole or as chips. Miscanthus and switchgrass can be harvested with standard farm equipment and, once harvested, may be stored outside until required. Alternatively, they may be left in the field to overwinter before harvesting which may reduce ash content but also reduce overall yield.
5. In addition to their use as a bioenergy feedstock, these crops can provide other environmental benefits, including soil stabilization, riparian buffering, and carbon sequestration.
6. Compared with traditional agricultural crops, purpose-grown grasses and short-rotation woody crops have significantly lower replanting costs (most are perennials), higher biomass production and carbon storage rates, and additional contaminant uptake and biodiversity benefits.

These six themes are discussed further in this chapter, which includes the following:

- A brief description of each bioenergy crop and its use as a source of renewable energy
- Availability and current production volumes
- Favorable locations for production
- Production and use costs and potential environmental and land use impacts

²³⁵ This category includes biomass from all types of trees (not just poplar and willow), including bark, sawdust, wood chips, wood scrap, and paper mill residues.

²³⁶ Total U.S. consumption of wood and wood-derived fuels in the United States in 2018 was 2,380 trillion British thermal units (TBtu), of which 221 TBtu were used for electricity production (EIA, 2010, tables 10.1 and 10.2c). Assuming 8,600 Btu/dry pound (Missouri, 2017), these are equivalent to 138.4 million tons and 12.9 million tons, respectively, for total wood consumed and wood used for electricity generation. Assuming that average wood production when clearcutting is 87 tons/acre, these would be equivalent to approximately 1.6 million acres of total wood consumed and approximately 150,000 acres used for electric power generation (Forest2Market, 2020). Similarly, if the wood was derived from tree trimmings only, the average is 32 tons/acre, this would be equivalent to approximately 4.3 million acres of tree trimming used for total consumption, and approximately 400,000 acres of tree trimming used for power generation (Forest2Market, 2020).

²³⁷ The U.S. Energy Information Administration does not currently track the amount of energy produced from Miscanthus or switchgrass. Using the conservative conversion that 1 ton of biomass = 80 gallons of ethanol, approximately 500,000 gallons of ethanol could have been produced from the 6,246 tons of switchgrass harvested in 2017, and approximately 3.3 million gallons of ethanol could have been produced from the 41,557 tons of Miscanthus harvested in 2017 (USDA, 2019i; USDA, 2019j).

BIOENERGY CROPS AND THEIR RENEWABLE ENERGY USES

This section provides an overview of the short-rotation woody crops poplar and willow, and the purpose-grown grasses switchgrass and Miscanthus, and their uses in the production of renewable energy.

EXHIBIT 8-1: Summary of Bioenergy Crop Characteristics

	Short-Rotation Woody Crops		Purpose-Grown Grasses	
	Poplar	Willow	Switchgrass	Miscanthus
Areas of Cultivation	Can grow in a wide range of areas, including Eastern States and the northern Pacific Coast.	Can grow on a wide range of Eastern States.	Native to the United States and can be grown throughout the country.	Native to Asia and grows best east of the Mississippi River.
Characteristics and Uses ¹	Fast growth (growth cycles of 3 to 13 years), high cellulose, and low lignin content (more energy and easier to extract). Can be grown as forestry trees or coppiced. ²³⁸	Fast growth (growth cycles of 3 to 4 years) and low ash content, usually coppiced.	Can be used for cellulosic ethanol and generation of heat and electricity through direct combustion, gasification, and pyrolysis.	Can be used for cellulosic ethanol, as well as to generate heat (including pelletized Miscanthus) and electricity.
Harvesting and Storage	Harvesting is similar to other small trees. Can be stored whole or as chips.	Harvesting is similar to other small trees. Can be stored whole or as chips.	Cut and baled using standard farm equipment. Can be stored as bales or allowed to overwinter in the field before cutting.	Cut and baled using standard farm equipment. Can be stored as bales or allowed to overwinter in the field before cutting.
Yields ²	Yields range from 1.25 to 8.6 dry tons/acre per year.	Yields range from 1.6 to 6.3 dry tons/acre per year.	Yields of 2 to 8 tons/acre, depending on the type.	Yields of 7 to 11 tons/acre.

¹ The term "fast growth" as used here is growth when compared to other temperate trees and woody shrubs. Trees and woody shrubs that are fast growth can produce significant biomass in a short period of time.

² Yields can vary significantly depending on many factors, including location, soil type, plant variety, harvesting time of year, and plant age before harvesting. Additionally, grass yields also can vary significantly depending on whether grasses are overwintered in the field before harvesting and, for switchgrass, the type of grass (lowland or upland) grown.

Short-Rotation Woody Crops

Poplar

Poplar (*Populus spp.*) trees consist of 25 to 35 species and are one of the fastest growing temperate trees, achieving growth rates of 5 to 10 feet/year (USDA, 2019a).²³⁹ Since first being commercially planted in the Pacific Northwest in the 1800s, poplars have been grown for pulp and paper; lumber; windbreaks; environmental improvements (e.g., soil carbon sequestration, sediment reduction, phytoremediation); and, more recently, for biofuel production (USDA, 2019a; DOE, 2016b). Current poplar research has focused on developing poplar hybrids with increased yield, resistance to pests, increased tolerance to diverse environments and conditions, and improved biomass quality for biofuel production (Stanton et al., 2019; USDA, 2019a; Volk et al., 2018, pp. 2 and 10).

Key characteristics that make poplar an excellent bioenergy crop candidate include the following:

²³⁸ Coppicing involves cutting the stand down just above the ground after 1 year to promote rapid growth of smaller side stems that can be harvested every 3 years over a 20-year period (Williams et al., 2018). "Coppiced" describes a shrub or tree that has been cut back to ground level.

²³⁹ Growth rates vary based on genetic differences among varieties and environmental conditions.

- Fast growth
- Chemical composition that allows for high production and easy extraction for liquid fuel production²⁴⁰
- Straightforward vegetative propagation
- Minimal input requirements
- Ability to grow in poor soils, including idle, retired, or low-productivity cropland
- Flexibility in harvesting time throughout the year and between harvests;²⁴¹ stands can be re-harvested multiple times before replanting (USDA, 2019a)

Poplar (including wood chips) can be used as a bioenergy feedstock for multiple types of energy production, including direct combustion to produce heat or generate electricity in power plants, and as a feedstock for liquid biofuels through hydrolysis and pyrolysis (USDA, 2019a; Ewanick & Bura, 2016, pp. 4378–4384). Examples of these uses include the following:

- A power plant in upstate New York where poplar hog fuel is being used to generate electricity (Townsend, et al. 2018, pp. 15–16)²⁴²
- A poplar biorefinery established in Boardman, OR, that produces acetic acid, ethyl acetate, and ethylene (AHBN, 2019)

Poplar grown for biomass is generally planted as a cutting²⁴³ (rooted or unrooted) taken from a healthy tree and is either grown as one main tree stalk or coppiced (see exhibit 8-2). Coppicing results in high energy yields per acre, maximized growth potential, and increased harvesting frequency compared with short-rotation forestry (Williams et al., 2018; Dou et al., 2017, p. 2). Depending on the energy conversion process, different growth practices, harvest timings, and poplar hybrids may be used to produce feedstocks. For example, for biofuel production, leaf removal before extraction results in a significant improvement in sugar recovery (Dou et al., 2017, p. 1).

Willow

Willows (*Salix spp.*) are comprised of more than 200 species of small to large perennial, broadleaf, water-loving plants in the Northern Hemisphere. Willows used for biomass production are fast-growing woody shrubs that can be converted into a range of bioenergy, biofuels, and bioproducts, while also providing multiple environmental benefits, such as soil remediation, riparian buffering, and carbon sequestration (Townsend, et al. 2018, p. 8; Volk et al., 2016, p. 8; Watts & Associates, 2011, p. 23). Originally considered as a potential biomass crop in the mid-1970s in Sweden, willow biomass trials have been conducted in 15 States throughout the United

EXHIBIT 8-2: Poplar Coppice



Source: USDA, 2011.

EXHIBIT 8-3: Coppiced Willow



Source: Townsend, et al. 2018, p. 7.

²⁴⁰ The poplar composition of high cellulose and low lignin provides the high levels of carbohydrates needed to produce energy for liquid fuels (high cellulose) with relative ease of extraction (low lignin) (USDA, 2019a).

²⁴¹ Depending on site-specific conditions, planting density, production practices, tree variety, and desired wood characteristics, poplars may be harvested every 2 to 13 years (USDA, 2019a).

²⁴² Hog fuel is a wood residue and waste product that is processed through a chipper or mill, and produces coarse chips and clumps that can be used for fuel.

²⁴³ A piece of poplar stem that has been cut from a healthy tree to provide vegetative propagation and continuity of the genetic strain. The cutting may be planted without roots or may be grown to develop roots before planting.

States since the late 1980s (Volk et al., 2016, p. 2). Current research on shrub willows includes breeding for increased yield and disease resistance, determining best management practices, and improving the biomass production pathway for biofuels (Volk et al., 2014).

Shrub willow characteristics that make them well suited for biomass production include the following:

- Fast growth/high yields in 3- to 4-year rotations²⁴⁴
- Straightforward vegetative propagation²⁴⁵
- Low ash content
- Ability to grow on marginal lands with few inputs
- Flexibility in harvesting time throughout the year (Volk et al., 2014)

Willows (including wood chips) can be used directly or co-fired to generate biopower, heat, and electricity, as well as to produce liquid biofuels (Townsend, et al. 2018, p. 24; Volk et al., 2014). Facilities in the United States currently using willow biomass include the following:

- ReEnergy Holdings, LLC, which uses shrub willow biomass at its ReEnergy Black River generating plant (see the following text box) and used shrub willow in its Lyonsdale 22 MW bio power facility in New York that was closed in 2019 (ReEnergy Holdings, 2019; USDA, 2019e).
- Attis Innovations, which recently announced that it will retool a Sunoco ethanol plant outside of Fulton, NY, to process biomass, including willow (Oswego County, 2019).

Internationally, shrub willow wood chips are used for a small amount for energy production in the United Kingdom, and multiple countries in the European Union (Germany, Latvia, Lithuania, Poland, and Sweden) have grown shrub willow for biomass energy production and bioremediation case studies (Ericsson & Werner, 2016, pp. 57–65; Rokwood, 2015, p. 79).²⁴⁶

Biomass Plant Partially Fired With Shrub Willow: ReEnergy Black River Plant

The ReEnergy Black River plant is located at the Fort Drum U.S. Army installation near Watertown, NY. The retooled, formerly coal-burning, facility produces approximately 422,000 net megawatt-hours of electricity each year, with a plant rating of 60 megawatts (ReEnergy Holdings, 2019). When signed in 2014, the contract was the largest renewable energy procurement contract in the history of the U.S. Army. Under the 20-year contract, the Black River facility provides 100 percent of the electricity used at Fort Drum, selling additional electricity to the regional grid. Eighty percent of the facility's wood fuel is forest residue from logging operations; the remainder is recovered construction and demolition wood, willow, and tire-derived fuel (USDA, 2019e).

To supply sufficient willow chips, the facility contracted with local farmers who established approximately 1,200 acres of shrub willow in 2013. By 2016, the Black River facility received about 1,160 tons of willow chips (Heavey et al., 2016, p. 1). During willow harvest years, ReEnergy expects that shrub willow could comprise up to 5 percent of the power plant's fuel supply (Renewable Energy World, 2013). Over the course of the current 11-year contract with farmers, ReEnergy expects to receive approximately 75,000 green tons of willow biomass for use in this and its other facilities (USDA, 2019e).



Example willow biomass harvest. Source: Eisenbies et al., 2014.

²⁴⁴ Willow biomass is typically grown using coppice management. Harvests can take place every 3 years, with between 7 to 10 harvest cycles occurring before yields start to decrease (Volk et al., 2014).

²⁴⁵ Typically, this propagation is from dormant hardwood cuttings.

²⁴⁶ The bioremediation case studies examined the use of coppiced willow to remediate a range of effluents, including municipal wastewater, landfill leachates, and industrial effluents (Rokwood, 2015, p. 79).

Purpose-Grown Grasses

Switchgrass

Switchgrass (*Panicum virgatum*) is a warm-season grass native to most of the continental United States (USDA, 2019f) (see *exhibit 8-4*). Key characteristics that make switchgrass an excellent bioenergy crop candidate include the following:

- Straightforward establishment from seed
- Grows well on marginal lands across most of the United States (see *exhibit 8-5* for range)
- Relatively high biomass yields compared with other crops
- Minimal input requirements
- Resistance to most pests
- Can be grown and harvested using conventional farming equipment
- Established seed industry (USDA, 2019f; USDA, 2017; DOE, 2016c)

There are two main types of switchgrass—upland and lowland. Upland varieties of switchgrass grow in areas typically above 200 meters (660 feet), while lowland varieties grow at lower elevations and in some areas that are flooded. While lowland types produce higher yields, upland varieties are better suited for most of the available production area in the United States (Lee et al., 2018, p. 699). Biomass field trials have found average relative maximum annual yields of 5.8 tons/acre per year for upland types and 9.8 tons/acre per year for lowland types (Lee et al., 2018, p. 704).

Switchgrass (including pelletized switchgrass, as seen in *exhibit 8-6*) can be used as a bioenergy feedstock for multiple types of energy production, including cellulosic ethanol and generation of heat and electricity through direct combustion, gasification, and pyrolysis (USDA, 2019f). Switchgrass has a similar composition to other feedstocks; however, depending on the growth environment, genetics, and harvest timing, it can have higher ash content (Mitchell et al., 2014, p. 4).²⁴⁷ While use of switchgrass as a feedstock is not currently economically viable at full commercial scale, there have been several demonstration projects using switchgrass as a bioenergy feedstock in the United States. These demonstration projects include the following:

EXHIBIT 8-4: Switchgrass



EXHIBIT 8-5: Native Range of Switchgrass in North America

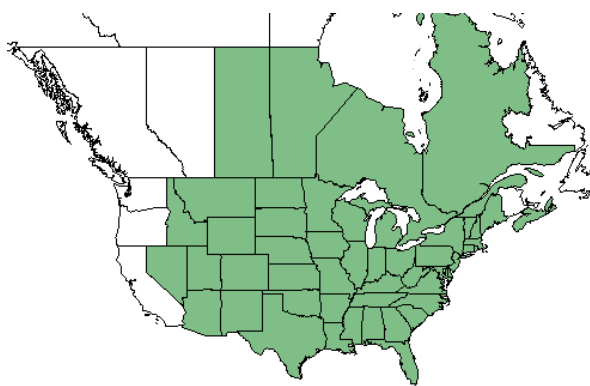

Source: USDA, 2019c.

EXHIBIT 8-6: Switchgrass Pellets



Source: USDA, 2010.

²⁴⁷ Switchgrass ash content varies greatly depending on harvest timing. Ash levels are lower after a late autumn harvest, a killing frost, or if the crop is overwintered in the field. Overwintering, however, can result in losing 25 percent to 30 percent of the total yield (USDA, 2018a; Mitchell et al., 2014, p. 4).

- Abengoa Bioenergy and Mid-Kansas Electric Company, LLC project developing the Nation's first commercial-scale hybrid cellulosic ethanol and power plant in Stevens County, Kansas (Mid-Kansas Electric, 2010)
- Alliant Energy project co-firing switchgrass at its power generating station in Ottumwa, Iowa (Biomass Magazine, 2019; Prairie Lands, 2006)
- Case study farm production of switchgrass pellets, Wood Crest Farm in Wapwallopen, PA (Penn State Extension, 2014)

Switchgrass is used as an energy feedstock in other countries. In Denmark, DONG Energy is a global leader in cellulosic biomass energy production and has recently been expanding feedstocks to include switchgrass (Inbicon, 2012). Unlike the United States, Canada has a developed market for switchgrass pellet production and specialized pellet stoves for decentralized home heating systems (Gemco Energy, 2020; USDA, 2018a). Producing switchgrass pellets for use in decentralized home heating systems is well developed, and pellet stoves are selling to individual homeowners as supplemental heating sources. These are similar to the "corn stoves" that burn waste or surplus corn or wood-waste pellets sold in the United States.

Miscanthus

Miscanthus (*Miscanthus x giganteus*) is a warm-season, sterile, tall perennial hybrid grass of subtropical origin (Brancourt-Hulmel, 2014). It is usually planted using rhizomes (roots) or plugs, and can be grown for 10 to 20 years, with peak growth occurring in 2 to 5 years (Brancourt-Hulmel, 2014).²⁴⁸ Exhibit 8-7 shows a Miscanthus plug and rhizome/root. Recent field trials across the United States demonstrated biomass yields of between 7 and 11 tons/acre per year of dry weight (Lee et al., 2018, 698–716). Exhibit 8-8 shows a map of Miscanthus yield potentials across the United States, with red dots indicating the location of field trial centers.

Key characteristics that make Miscanthus an excellent bioenergy crop candidate include the following:

- Ability to grow with limited nutrients and water
- Capacity to restore carbon and nitrogen to depleted soils
- Rapid growth rates and high potential biomass yields
- Sterile and non-invasive
- 20-year lifespan
- No native pests or diseases in the United States (Witzel and Finger, 2016, p. 26; Brancourt-Hulmel, 2014)

EXHIBIT 8-7: Miscanthus Plug (left) and Rhizome (right)



Source: Boersma & Heaton, 2011, p. 1.

²⁴⁸ Plugs are seedlings that have been germinated and grown in trays, usually in greenhouses.

EXHIBIT 8-8: Biomass Yield Potential for Miscanthus

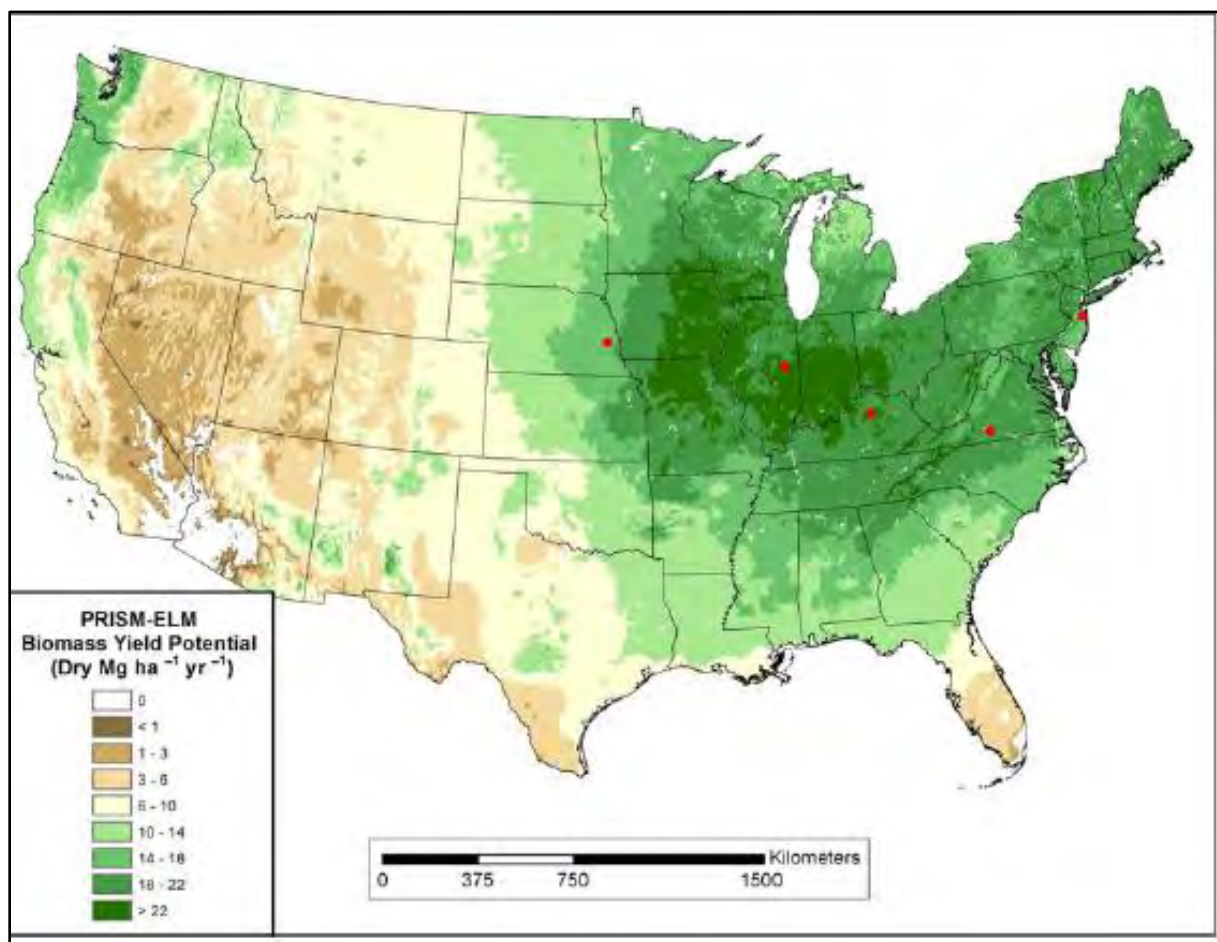

Source: Lee et al., 2018, p. 707, figure 4.

Miscanthus can be used to produce cellulosic ethanol, as well as to generate heat (including pelletized Miscanthus) and electricity (USDA, 2019g; Brancourt-Hulmel, 2014).²⁴⁹ Depending on growth conditions, the energy content of Miscanthus is comparable to wood,²⁵⁰ meaning that Miscanthus could be used as a substitute for woody biomass. However, due to a lack of infrastructure for harvesting and processing, limited markets for its sale and use, and high start-up costs compared with other energy sources, Miscanthus is not currently grown as a commercial biomass fuel crop in the United States (USDA, 2018b; Hoque, 2014, pp. 1–8; Jacobson, 2013). There are pilot projects, such as the University of Iowa biomass fuel project, that are using Miscanthus as a fuel.

Internationally, Miscanthus has been investigated as a biomass energy source in the European Union since the early 1990s (Heaton et al., 2010, p. 92). Recently funded research to improve the supply chain and use Miscanthus as a biomass energy source (e.g., the GRACE project)²⁵¹ has resulted in the successful testing of 30 tons of Miscanthus as a feedstock for lignocellulosic sugars and ethanol in Germany (Advanced Biofuels USA, 2019). Other demonstration projects include three large-scale field trials (in the United Kingdom, Germany, and Ukraine) to test different varieties of Miscanthus and to, among other tests, quantify energy use in densification (pellet) technologies with a range of hybrids with differences in stem wall properties. However, as in the United States, high production costs and lack of infrastructure have

²⁴⁹ Other uses of Miscanthus include animal bedding, pulp and paper, cellulose fibers, and biocomposites (Hedrick, 2017, pp. 1–14).

²⁵⁰ Miscanthus has an energy content of ~19 megajoules/dry kilogram (≈16 gigajoules/dry ton or ≈15.5 million Btu/dry ton) (OMAFRA, 2020, table 1).

²⁵¹ "Growing advanced industrial crops on marginal lands for bio-refineries" (GRACE, 2019).

limited the wide-scale use of Miscanthus as a biomass source in the European Union (Lewandowski et al., 2016, p. 1).

University of Iowa Biomass Fuel Project

The biomass fuel project is part of the university's 2020 Sustainability Vision to achieve 40 percent renewable energy by 2020 and a coal-free campus by 2025 (University of Iowa, 2019a). By transitioning the local solid fuel boilers at the main power plant from coal to biomass, the goals of the project are to (1) develop a diverse renewable fuel portfolio, which will allow the university to buy local solid fuel; and (2) potentially return more than \$10 million annually to the local rural economy.

To ensure access to sufficient Miscanthus biomass, the university is partnering with farmers within 50 miles of Iowa City to grow Miscanthus. Since 2013, more than 1,200 acres of Miscanthus have been planted with the goal of 2,500 planted acres by 2020 that will produce 22,500 tons of biomass annually (University of Iowa, 2019b; Iowa Now, 2017). This amount of Miscanthus biomass will account

for approximately 25 percent of the university's energy production (University of Iowa, 2019; Iowa Now, 2017).



Source: Iowa Now, 2019.

AVAILABILITY AND CURRENT PRODUCTION OF BIOENERGY CROPS

In this section, information is provided on the levels of production of short-rotation woody crops and purpose-grown grasses. There is limited recent data on the availability and production volumes of these crops due to their relative rarity in the U.S. agricultural and forestry industries. The data that are available from the USDA Census of Agriculture (USDA, 2020b) and the Billion-Ton Report (DOE, 2016c) can show significant variances. According to the USDA Census, some data are not reported "to avoid disclosing data for individual operations," and the Billion-Ton Report notes that "these acres are underestimated; producers often do not report plantings of unique crops because they are not enrolled in Federal commodity programs, or the crops are grown on non-private agricultural lands (e.g., public universities, regional extension farms)" (DOE, 2016b, p. 28). It should also be noted that the USDA Census data are based on actual census returns from farmers and others, while the Billion-Ton Report data are estimates "based on the best available, but very limited, field-based data and expert judgment" (Volk et al., 2018, p. 2). With these caveats, the information presented below provides an indication of the overall volumes of these bioenergy crops.

Short-Rotation Woody Crops

Poplar

According to USDA Census of Agriculture data, around 640 acres of hybrid poplar were in production as short-term woody crops in 2014, producing nearly 29 tons/acre of green wood (USDA, 2019c). The number of poplar acres harvested decreased from 734 in 2009 (worth approximately \$2 million) to 133 in 2014 (worth approximately \$310,000), but the number of operations in production remained relatively constant, with 15 in 2009 and 14 in 2014 (USDA, 2019c).²⁵² These acreages vary from the Billion-Ton Report, which estimates that 2,554 acres of hybrid poplar were grown in November 2014, but does note that "hybrid poplar acres in production increased from 211 acres in August 2014 to 2,554 acres in November 2014" (DOE, 2016b, p. 28). A separate estimate in 2018 indicated that 300 acres of hybrid poplar were grown for commercial energy production in 2018 (Volk et al., 2018, p. 2). Exhibit 8-9 provides a summary of poplar production data.

²⁵² In part, this reported reduction in hybrid poplar acres harvested between 2009 and 2014 was due to the cyclic nature of harvesting. It was also due to the limited data reported by some farmers and other growers.

EXHIBIT 8-9: USDA Census Data for Hybrid Poplar Production in 2009 and 2014

Year	Acres in Production	Acres Harvested	Number of Operations With Areas in Production	Production in Tons (green basis)	Sales in \$
2009	D ¹	734	15	D ¹	1,977,720
2014	639	133	14	18,951	310,500

¹ D = Data withheld during the USDA Census to avoid disclosing data for individual operations.

Source: USDA, 2019c.

Exhibit 8-10 shows a map of hybrid poplar acres in production as short-term woody crops by State in 2014, with each State color coded by the number of acres grown.

EXHIBIT 8-10: Hybrid Poplar Acres in Production in 2014 by State From USDA Census Data

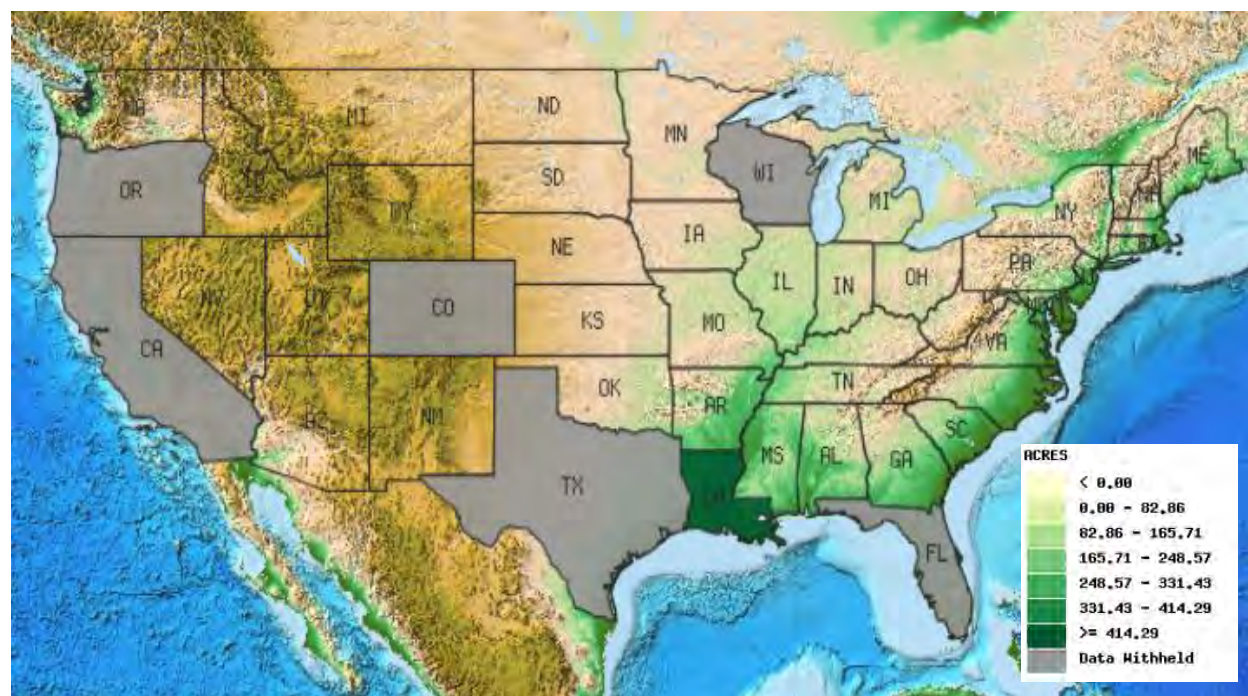

Source: USDA, 2019h.

Willow

There is currently no comprehensive data collection on the number of acres of willow grown for biofuel production. However, it is estimated that approximately 1,200 acres of shrub willow were grown for commercial energy in 2018 and that more than 1,300 acres of shrub willow were grown on private lands in upstate New York (Townsend, et al., 2018, p. 15; Volk et al., 2018, p. 2).

Purpose-Grown Grasses

Switchgrass

Switchgrass production decreased from 2012 to 2017 (USDA, 2019i). *Exhibit 8-11* shows the number of switchgrass acres harvested, the tons of switchgrass produced, and the number of operations growing switchgrass in 2012 and 2017.

Source: USDA, 2019i.

EXHIBIT 8-11: USDA Census Data for Switchgrass Production in 2012 and 2017

Year	Acres Harvested	Production (tons)	Number of Operations That Harvested Switchgrass
2012	3,082	11,795	41
2017	978	6,246	21

does not include acres for the Ottumwa (Iowa) Generating Station discussed in the adjacent text box (Biomass Magazine, 2019).

EXHIBIT 8-12: USDA Census of Agriculture Switchgrass Acres Harvested by State in 2017

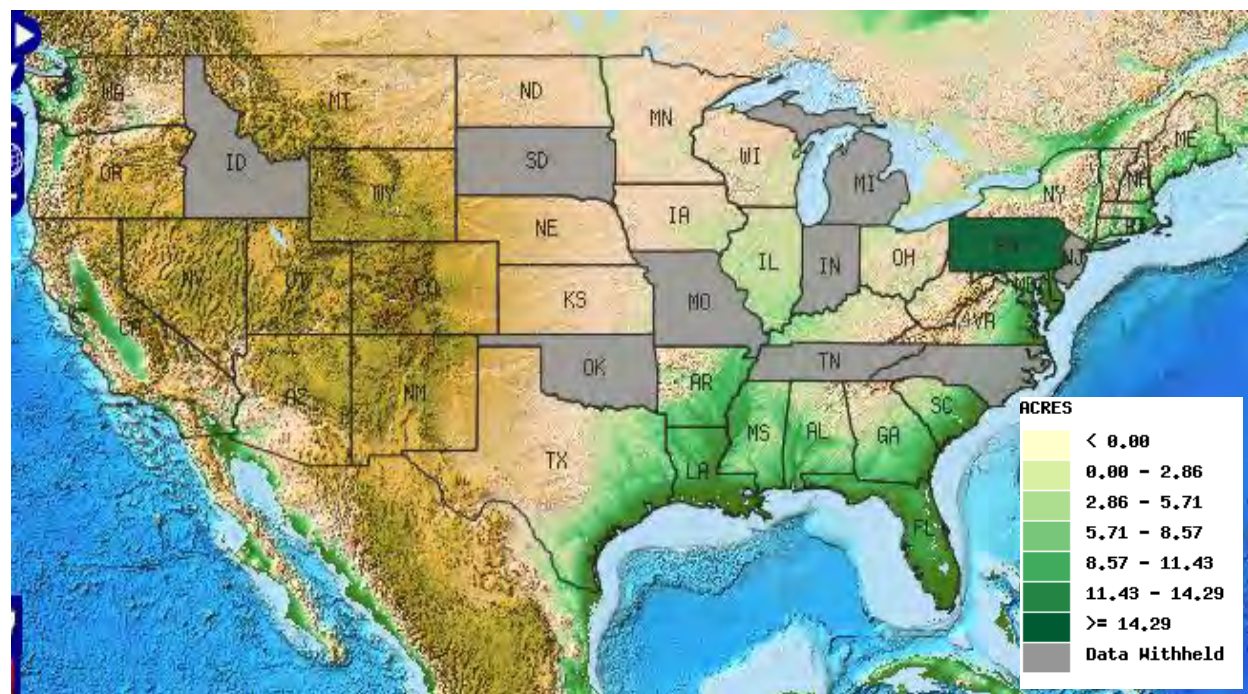

Source: USDA, 2019h.

Co-Firing With Switchgrass: Alliant Energy Corp. Plant in Ottumwa, Iowa

Alliant Energy Corp. in Ottumwa, IA, is gearing up to co-fire coal with 5 percent switchgrass to produce a total of 726 megawatts (MW) of electricity annually (35 MW of which would be generated by switchgrass) (Biomass Magazine, 2019). Approximately 40,000 to 50,000 acres are needed to produce the 200,000 tons of switchgrass required to feed the plant annually (USDA, 2018a). Production is estimated to begin in the next 2 to 3 years (Biomass Magazine, 2019).

Miscanthus

Miscanthus production increased from 2012 to 2017 (USDA, 2019j). Exhibit 8-13 shows the number of Miscanthus acres harvested, the tons of Miscanthus produced, and the number of operations growing Miscanthus in 2012 and 2017.

Exhibit 8-14 shows a map of Miscanthus acres harvested by State, with each State color coded by the number of acres grown.

EXHIBIT 8-13: USDA Census Data for Miscanthus Production in 2012 and 2017

Year	Acres Harvested	Production (tons)	Number of Operations That Harvested Miscanthus
2012	D ¹	D ¹	5
2017	5,400	41,557	50

¹ D = Data withheld to avoid disclosing data for individual operations.

Source: USDA, 2019j.

EXHIBIT 8-14: USDA Census of Agriculture Miscanthus Acres Harvested by State in 2017

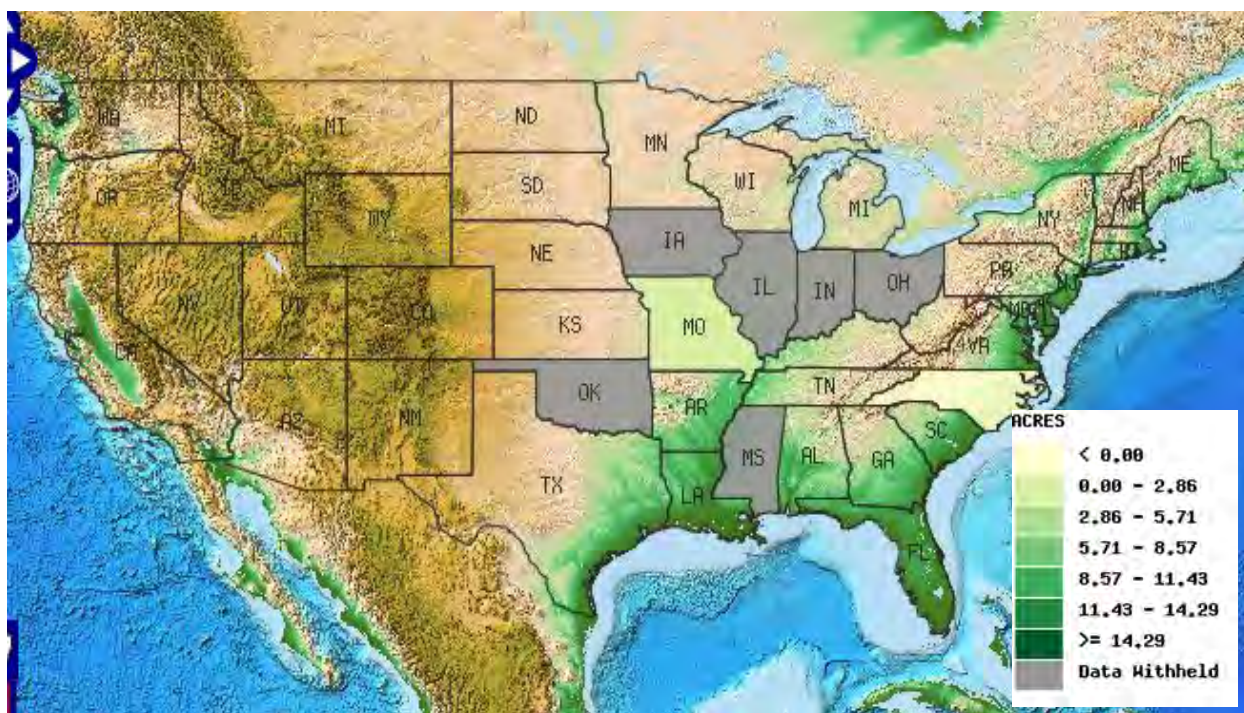

Source: USDA, 2019h.

FAVORABLE LOCATIONS FOR PRODUCTION

This section presents the areas within the United States that are favorable for potential production of both short-rotation woody crops and purpose-grown grasses.

Short-Rotation Woody Crops

Poplar

Poplars can grow throughout the continental United States and Alaska, and tend to grow best in areas with high moisture and full sun (USDA, 2019a). Active research in developing new hybrid varieties is increasing yield and expanding potential production to areas where there is less moisture and sun within the United States (USDA, 2019a).

In terms of potential future production, data from field trials combined with computer mapping indicate that the Eastern half of the United States (i.e., east of the Mississippi River) and the Northwest

region are most likely to produce the highest yield rates for dried poplar given current varieties (Volk et al., 2018, p. 9).

In addition to favorable production areas, poplar plantations for biomass production will also need to be in close proximity to potential biorefineries and/or biopower facilities in order to limit transportation costs (AHBN, 2019; USDA, 2019a; DOE, 2016b).

Willow

All current willow biomass trials have been conducted in the Eastern portion of the United States (see the red dots in *exhibit 8-15*). In terms of potential future production, data from field trials combined with computer mapping indicate that the Eastern half of the United States (i.e., east of the Mississippi River) contains areas most likely to produce the highest willow yields for existing varieties (Volk et al., 2018, p. 9).

EXHIBIT 8-15: Potential Shrub Willow Biomass Yields in the United States

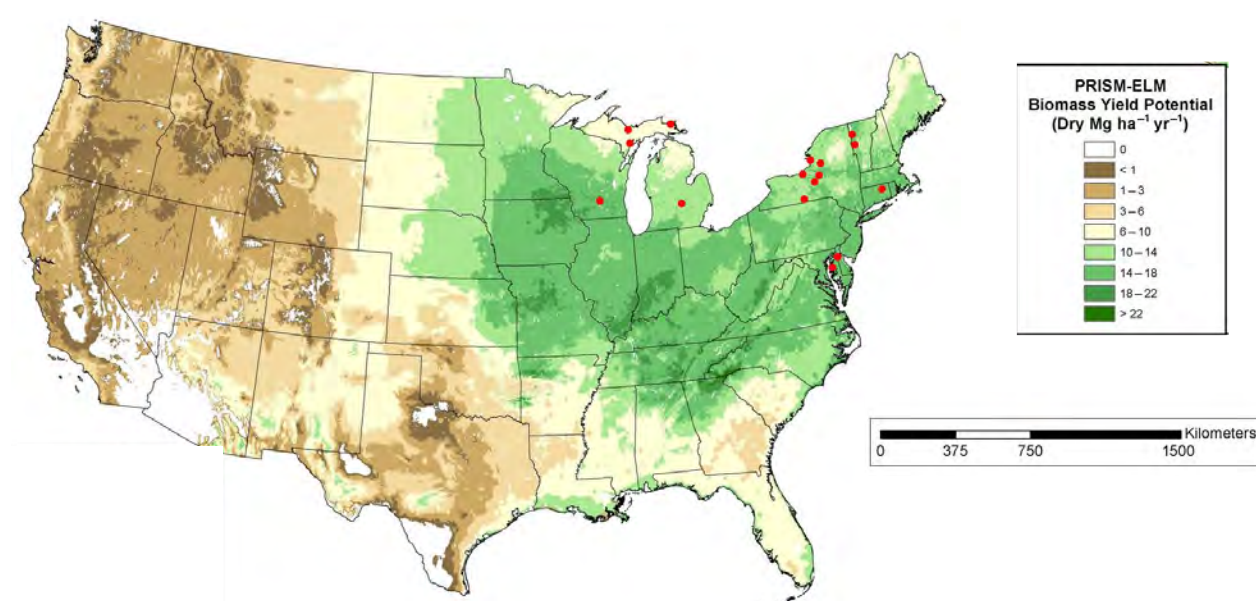

Source: Volk et al., 2018, p. 10, figure 5.

Purpose-Grown Grasses

Switchgrass

While there currently is no commercial switchgrass grown for bioenergy feedstock, the Midwest is considered to be a prime location for future switchgrass production. Marginal lands currently enrolled in the Conservation Reserve Program (CRP)²⁵³ could be used to grow switchgrass for energy production without impacting land currently used to grow other crops (USDA, 2018a; USDA, 2019f). Most acreage enrolled in the CRP is in the Midwest region.

Increased use of switchgrass for energy production is dependent upon increasing switchgrass yields and lowering production costs through improving genetics and conducting multi-year field trials (Lee et al., 2018; USDA, 2019h; USDA, 2018a). Research centers working to increase switchgrass-based bioenergy production are located throughout the United States (USDA, 2018a).

²⁵³ The Conservation Reserve Program (CRP) is a voluntary program aimed at conserving soil, water, and wildlife resources by removing highly erodible and environmentally sensitive lands from agricultural production and installing resource-conserving practices. The program is administered by USDA's Farm Service Agency (USDA, 2020c).

Miscanthus

As with switchgrass, there currently is no commercial production of Miscanthus for bioenergy production. Areas with greater than 30 inches of rain per year, however, are considered to be prime locations for future Miscanthus production (USDA, 2019g). Lands currently enrolled in the CRP and marginal lands that are currently in crop production are the most likely lands that would be used to grow Miscanthus for bioenergy purposes (USDA, 2019g; Lee et al., 2018, 698–716).

PRODUCTION AND USE COSTS AND POTENTIAL ENVIRONMENTAL AND LAND USE IMPACTS

This section provides an overview of the costs for growing, harvesting, transporting, and processing bioenergy crops as well as potential environmental and land use impacts if production of these crops increased significantly. There is limited data available on production costs due to the limited growth and production of bioenergy crops in the United States. Hence, the available information should be viewed as indicative of actual costs. Where appropriate, cost data have been adjusted to 2020 dollars.

All short-rotation woody crops and purpose-grown grasses used as biomass energy sources incur costs for planting, harvesting, transporting, and processing the feedstock.²⁵⁴ Depending on the end-use of the biomass, they may also incur storage costs. Wood or wood chips may need to be stored to reduce moisture content (USDA, 2019e). Switchgrass and Miscanthus may be stored or overwintered in the field before use. Storage and overwintering can reduce the high ash levels of these feedstocks as natural leaching reduces the silica and chloride content; however, storage increases costs and overwintering and storage can both reduce yields resulting from loss of some combustible products due to partial decomposition (USDA, 2018a; USDA, 2018b; Mitchell et al., 2014, p. 4).

Exhibit 8-16 provides a summary of the cost data that are available.^{255,256}

EXHIBIT 8-16: Comparison of Typical \$/MMBtu Delivered Biofuel Costs (All Prices Adjusted to 2020 Dollars)

	Poplar	Willow	Switchgrass		Miscanthus	
State	MN	IL	IA	IA	IL	IA
Original Data Year	2007 ¹	2016 ²	2008 ³	2005 ⁴	2003 ⁵	2014 ⁶
Production*	\$5.33	\$6.22	\$5.71	\$3.36	\$3.73 – 5.71	\$2.50
Transportation to Storage*	\$0.73		\$0.42	–	\$0.41 – 1.99	–
Storage*			\$1.16	–	–	–
Transportation to Plant*	\$3.92	*\$1.52	\$0.60	\$0.78	–	–
Handling and Grinding*			–	\$1.25	–	–
Process Facility Costs*	\$0.07	\$0.00	\$0.00	\$0.78	–	–
Total Costs	\$10.05	\$7.74	\$7.89	\$6.17	\$4.14 – 7.70	\$2.50

* All costs are shown in \$/MMBtu, assuming 8,500 Btu/dry pound, and are adjusted to 2020 dollars.

Data Sources:

¹ CEE, 2007, p. 39, figure III-14; ² Ssegane et al., 2016, p. 785; ³ Duffy, 2008, p. 4; ⁴ Walling, 2005, p. 25; ⁵ Khanna, 2008, pp. 482–493; ⁶ Hoque, 2014, pp. 4–8.

²⁵⁴ Note that some poplar is processed into woodchips during harvesting, in which case, harvesting and processing are one combined cost (USDA, 2019e).

²⁵⁵ Because cost data were published for different years, for comparison purposes, all were converted to 2020 dollars using the U.S. Bureau of Labor Statistics (BLS), Consumer Price Index (CPI) Inflation Calculator (<https://data.bls.gov/cgi-bin/cpicalc.pl>). Price escalation was calculated from the middle of the year of the data to February 2020. This resulted in the following aggregate escalation rates: 2003 – 41 percent; 2005 – 33 percent; 2007 – 24 percent; 2008 – 18 percent; 2014 – 9 percent.

²⁵⁶ Because some data were available only as costs per dry ton while others were available as costs per MMBtu, all have been adjusted to costs per MMBtu, assuming energy content is 8,500 Btu/dry pound.

The following provides a brief summary of the additional limited cost and comparative data that are available for each of these energy crops.

Costs for Short-Rotation Woody Crops

Poplar

For poplar, harvesting and transportation can account for 39 percent to 60 percent of all production expenses (Elbheri et al., 2008, p. 56). However, harvesting coppice trees can be cheaper, and new harvesting methods may increase yields and reduce prices (USDA, 2019a; DOE, 2017, p. 32).

A study of typical fuel costs in Minnesota provides a cost comparison of poplar compared with other potential fuel sources. When estimating the costs of different energy sources per MMBtu in 2007, it was found that hybrid poplar was the most expensive at \$8.11/MMBtu, followed by switchgrass at \$6.20/MMBtu, logging residues at \$5.01/MMBtu, and coal at \$1.08 – \$2.60/MMBtu (CEE, 2007, p. 39, figure III-14). Exhibit 8-17 shows the breakdown in costs of the four different potential fuels in 2020 dollars.

EXHIBIT 8-17: Comparison of Typical Delivered Fuel Costs in Minnesota (2007 Prices Adjusted to 2020 Dollars)²⁵⁷

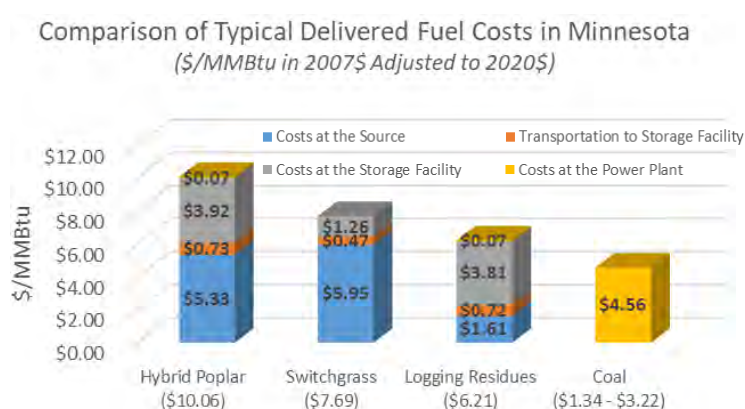

Source: CEE, 2007, p. 39, figure III-14.

Another study looking at pricing for hybrid poplar for four tree plantations in the Western States found that to make positive returns, all four required prices over two and a half times (approximately \$110/dry ton) the current market price (approximately \$42/dry ton) (Chudy et al., 2019, pp. 114–124). While cost breakdowns varied by site, on average, land acquisition was the largest component of total cost over the 22-year investment period (39 percent); followed by harvest and transport (30 percent); plant material (20 percent); and operational, administrative, and property management expenses (11 percent). To date, high planting and harvesting costs, limited markets, and insufficient policy and regulatory support have been key barriers to developing commercial poplar biomass markets (Townsend, et al. 2018, p. 18).

Willow

Studies on willow production also indicate that harvesting is the largest component of production costs (DOE, 2017). A shrub willow budget developed by Penn State estimated harvesting at approximately 70 percent of total annual cash expenses for peak stand harvesting years (tree ages 7–22 years) (Jacobson, 2014, p. 2).²⁵⁸ The Penn State budget estimated total costs of \$3,513/acre and total revenues of \$3,780/acre over a 22-year period, resulting in a net income of \$267/acre over the budget period and a breakeven payback period of about 7 years. Assuming a 4 percent discount rate (i.e., opportunity cost interest rate), the annualized net present value (NPV) of this income is –\$16/acre per year (Jacobson, 2014, p. 3). The EcoWillow model covering New York State estimates a breakeven payback of 13 years, with harvesting comprising 32 percent of costs; establishment comprising 23 percent of costs; land rent comprising 16 percent of costs; and crop removal, administration, and fertilizers comprising the remaining costs (29 percent) (DOE, 2017). Modeling of willow production in Indiana found that regardless of the

²⁵⁷ Cost data were in 2007 dollars in the report. For EXHIBIT 8-17, data were converted to 2020 dollars using the BLS CPI Inflation Calculator (<https://data.bls.gov/cgi-bin/cpicalc.pl>), which increased prices by an aggregate 24 percent between June 2007 and February 2020.

²⁵⁸ Harvesting is comprised of cutter, shipper, and wagon costs.

mode of cropping, business practices, or landscape design, growing shrub willows was unlikely to provide positive revenues (Ssegane et al., 2016, p. 1). Models project revenues of –\$67 to –\$303/hectare per year at a biomass price of \$46.30/wet metric ton (Ssegane et al., 2016, p. 1).

Similar to poplar, current models indicate that without carbon and nutrient credit trading programs, integration of willow into existing markets, and/or long-term policy support at the Federal and State level, it is unlikely that willow biomass will become economically viable (Townsend, et al. 2018, p. 25).

Costs for Purpose-Grown Grasses

Switchgrass

As there is currently no commercial energy production from switchgrass, there are limited data for actual costs. In one multi-State study, switchgrass production costs were established by growing switchgrass on 10 commercial-scale fields between Northern North Dakota through Southern Nebraska for 5 years. Overall, average costs were \$59/dry ton biomass at an average yield of 2.2 tons/acre per year (Perrin et al., 2008, p. 4). At the lower end of cost, farmers were able to produce switchgrass at \$47/dry ton, with projected 10-year rotation costs of \$42/ton (Perrin et al., 2008, p. 4).

More detailed price information is available from modeled and actual costs (exhibit 8-18). In terms of modeled costs, based on 2007 prices and switchgrass yields in Iowa, an academic model estimated the costs of producing and transporting switchgrass to a facility producing ethanol (Duffy, 2008, pp. 1–8).²⁶⁰ For actual costs, the Ottumwa Generating Station demonstration project (see text box on page 8-11) provides a more complete picture of costs associated with co-firing switchgrass biomass with coal. The data indicates that more than half of the costs (approximately 54 percent) are from switchgrass production (Walling, 2005, p. 25).

Currently, the costs associated with producing and using switchgrass as a biomass fuel source are higher than for other fuel sources. For example, in 2019, Alliant Energy estimates that they would pay \$55 to \$65/ton for switchgrass in addition to paying \$20/ton for processing the biomass for energy use (Biomass Magazine, 2019). For comparison, coal costs less than \$20/ton delivered, and woodchips cost \$100 to \$200/ton delivered (Biomass Magazine, 2019; Energy Pellets, 2019; Forest2Market, 2018). It will likely require government incentives (e.g., tax credits, cost sharing, loan guarantees) or significantly different energy market conditions to make switchgrass a competitive fuel source (Biomass Magazine, 2019).

EXHIBIT 8-18: Breakdown of Modeled and Actual Costs for Switchgrass for Use in Biomass Energy Generation – Iowa (All Prices Adjusted to 2020 Dollars)

Cost Categories for Using Switchgrass for Biomass Energy Production*	Duffy Model	Ottumwa Generation Station Demonstration Project
Original Data Year	2008 ¹	2005 ²
Production	\$97.03	\$57.19 ²⁵⁹
Transportation to Storage	\$7.20	–
Storage	\$19.67	–
Transportation to Plant	\$10.21	\$13.30
Handling and Grinding	–	\$21.28
Process Facility Ownership Costs	–	\$13.30
Total Costs	\$134.11	\$105.07

* Costs shown in \$/dry ton adjusted to 2020 Dollars.

Data Sources: ¹ Duffy, 2008, p. 4; ² Walling, 2005, p. 25.

²⁵⁹ Ottumwa Generating Station switchgrass total production costs include the combined value of closed-loop producer ownership costs (\$13) and production costs to the edge of the field (\$30).

²⁶⁰ Some of the assumptions include an \$80/acre land charge, switchgrass yield of 4 tons/acre, 100 pounds of nitrogen per acre is used, fall harvesting, hoop-type structure for bale storage, and a 30-mile trip to the energy plant. For more information on assumptions, visit <https://www.extension.iastate.edu/agdm/crops/pdf/a1-22.pdf>.

Miscanthus

Major differences in costs/benefits between growing Miscanthus and switchgrass are the following:

1. The rhizomes or plugs used to plant Miscanthus, are more costly to purchase and plant than switchgrass seeds.
7. Miscanthus yields can be approximately three to six times higher than switchgrass yields, resulting in lower overall breakeven costs despite higher initial start-up costs (Khanna, 2008, pp. 482–493).

As with switchgrass, there is currently no commercial energy production from Miscanthus. There are, however, some model-derived cost estimates for Miscanthus used in co-firing with coal to produce electricity. One study combined estimated Miscanthus yields with estimated production and transportation costs to determine breakeven prices for Miscanthus co-fired with coal to produce energy across Illinois (Khanna, 2008, pp. 482–493). The largest portion of the breakeven cost for Miscanthus was harvesting. Another study estimated the costs of planting and growing a 20-year Miscanthus stand in Iowa (Hoque, 2014, pp. 4–8). The model indicates high upfront costs for preparing (\$445/acre) and planting fields (\$1,130/acre).

EXHIBIT 8-19: Breakdown of Modeled Costs for Miscanthus for Use in Biomass Energy Generation (All Prices Adjusted to 2020 Dollars)

Cost Categories for Using Miscanthus for Biomass Energy Production*	Khanna (2008) Illinois	Hoque (2014) Iowa
Original Data Year	2003 ¹	2014 ²
Production	\$63.45 – 90.24	\$42.51 ²⁶¹
Transportation to Plant	\$7.05 – 33.84	–
Total Costs	\$70.50 – 124.08	\$42.51

* Costs shown in \$/dry ton adjusted to 2020 dollars.

Data Sources: ¹ Khanna, 2008, pp. 482–493; ² Hoque, 2014, pp. 4–8.

Looking at Miscanthus breakeven prices based on the type of energy produced in the Northeastern United States, it was found that pellet energy had the lowest breakeven price (\$9.2/gigajoule [GJ]), followed by biofuel production (\$27.9/GJ) and biopower (\$45.5/GJ) (Liu et al., 2017, p. 17).

Currently, the costs associated with producing and using Miscanthus as a biomass fuel source are higher than some other fuel sources. For example, the delivered cost per unit of heat energy of Miscanthus in Illinois is between \$2.45/GJ and \$4.42/GJ. For comparison, the delivered cost of coal energy is \$1.123/GJ. As with switchgrass, it will likely require incentives (such as carbon credits) to make Miscanthus a competitive fuel source (Khanna, 2008, pp. 482–493).

Potential Environmental and Land Use Impacts

Increased use of forestry and agriculture energy crops in biomass power generation systems is likely to reduce greenhouse gas (GHG) emissions compared to fossil fuel generating technologies, as long as sustainable crop management practices are followed. The Adoption Impacts section of Chapter 3 describes these GHG impacts and provides example calculations.

There are also, however, potential negative impacts if energy crop volumes rise significantly (EIA, 2019c). For example, the combustion of energy crops in biomass power generation systems creates non-carbon air emissions and causes nitrogen deposition that can acidify soils and waters and, thereby, affect species composition. There may also be negative environmental issues associated with increased fertilizer applications and increased withdrawals of irrigation water. Finally, while Miscanthus and switchgrass can grow well on marginal agricultural lands, significantly scaling up production may create local and regional conflicts associated with shifting lands now in production of other crops, grasslands, forests, and other uses into production of these energy crops.

²⁶¹ Value is based on an annual cost per acre of \$393/acre per year and a projected yield of 10 dry tons/acre per year.

REFERENCES

- Advanced Biofuels USA. 2019. Clariant Successfully Concludes Testing of Energy Crop Miscanthus at Straubing Plant for GRACE Project. <https://advancedbiofuelsusa.info/clariant-successfully-concludes-testing-of-energy-crop-miscanthus-at-straubing-plant-for-grace-project/> [accessed March 2020].
- AHBN. 2019. Questions & Answers. Advanced Hardwood Biofuels Northwest. <https://hardwoodbiofuels.org/about/faq/> [accessed March 2020].
- Biomass Center. 2017. Grass Energy Basics. <https://www.biomasscenter.org/resource-library/fact-sheets/grass-energy-basics> [accessed March 2020].
- Biomass Magazine. 2019. Switchgrass Pioneers. <http://biomassmagazine.com/articles/1255/switchgrass-pioneers> [accessed March 2020].
- Boersma, N., & Heaton, E. 2011. *Giant Miscanthus – Rhizomes v. Plugs*. Iowa State University Extension and Outreach. <https://store.extension.iastate.edu/product/13726> [accessed March 2020].
- Brancourt-Hulmel. 2014. Miscanthus Genetics and Agronomy for Bioenergy Feedstock. *Cellulosic Energy Cropping Systems*, 43–73. Brancourt-Hulmel, M., Demay, C., Rosiau, E., Ferchaud, F., Bethencourt, L., Arnoult, S., ... & Boizard, H.
- CEE. 2007. *Identifying Effective Biomass Strategies: Quantifying Minnesota's Resources and Evaluating Future Opportunities*. The Center for Energy and Environment. <https://www.mncee.org/getattachment/Resources/Resource-Center/Technical-Reports/Identifying-Effective-Biomass-Strategies-Quantify/Identifying-Effective-Biomass-Strategies.pdf.aspx> [accessed June 2020]
- Chudy et al. 2019. *The Economics of Dedicated Hybrid Poplar Biomass Plantations in the Western US*. *Biomass and Bioenergy*, Volume 124. Chudy, R. P., Busby, G. M., Binkley, C. S., & Stanton, B. J.
- DOE. 2016a. *Future Bioeconomy Supported by More Than One Billion Tons of Biomass Potential*. U.S. Department of Energy. <https://www.energy.gov/eere/articles/future-bioeconomy-supported-more-one-billion-tons-biomass-potential> [accessed May 2020].
- DOE. 2016b. *2016 Billion-Ton Report: Advancing Domestic Resources for a Thriving Bioeconomy*, Volume 1: Economic Availability of Feedstock. U.S. Department of Energy, Oak Ridge National Laboratory. Langholtz, M. H., Stokes, B. J., & Eaton, L. M. (Leads). ORNL/TM-2016/160. doi: 10.2172/1271651. <http://energy.gov/eere/bioenergy/2016-billion-ton-report> [accessed March 2020].
- DOE. 2016c. *Regional Feedstock Partnership Summary Report: Enabling the Billion-Ton Vision*. U.S. Department of Energy. Owens, Vance N., Karlen, Douglas L., & Lacey, Jeffrey A. doi: 10.2172/1332062. <https://www.osti.gov/servlets/purl/1332062> [accessed March 2020].
- DOE. 2017. *Improved Advanced Biomass Logistics Utilizing Woody Feedstocks in the Northeast and Pacific Northwest*. Volk, Timothy. U.S. Department of Energy, Bioenergy Technologies Office. https://www.energy.gov/sites/prod/files/2017/05/f34/fsl_volk2_123108.pdf [accessed March 2020].
- Dou et al. 2017. Can We Use Short Rotation Coppice Poplar for Sugar Based Biorefinery Feedstock? Bioconversion of 2-Year-Old Poplar Grown as Short Rotation Coppice. *Biotechnology for Biofuels*, June 5, Issue 10, Article144. Dou, C., Marcondes, W. F., Djaja, J. E., Bura, R., & Gustafson, R. <https://doi.org/10.1186/s13068-017-0829-6> [accessed February 2020].
- Duffy, M. 2008. Estimated Costs for Production, Storage and Transportation of Switchgrass. *Ag Decision Maker*. Iowa State University, University Extension. <https://www.extension.iastate.edu/agdm/crops/pdf/a1-22.pdf> [accessed March 2020].
- EIA. 2019a. Biomass Explained. U.S. Energy Information Administration, DOE. https://www.eia.gov/energyexplained/index.php?page=biomass_home [accessed May 2020].
- EIA. 2019b. *Biomass Explained: Wood and Wood Waste*. U.S. Energy Information Administration, DOE. <https://www.eia.gov/energyexplained/biomass/wood-and-wood-waste.php> [accessed March 2020].
- EIA. 2019c. Biomass Explained: Biomass and the Environment. U.S. Energy Information Administration, DOE. <https://www.eia.gov/energyexplained/biomass/biomass-and-the-environment.php#:~:text=Energy%20Information%20Administration%20-%20EIA%20-%20Official%20Energy,impacts%20of%20producing%20and%20using%20biomass%20for%20energy> [accessed August 2020].
- EIA. 2020. Total Energy – Monthly Energy Review. U.S. Energy Information Administration, DOE. <https://www.eia.gov/totalenergy/data/monthly/#renewable> [accessed March 2020].
- Elbheri et al. 2008. *The Economics of Biomass Feedstocks in the United States: A Review of the Literature*. Biomass Research and Development Board. Elbheri, A., Coyle, W., Dohlman, E., Kmak, H., Ferrell, J., Haq, Z., ... & Patton-Mallory, M. https://www.biomassboard.gov/pdfs/feedstocks_literature_review.pdf [accessed March 2020].
- Energy Pellets. 2019. Energy Pellets of America. <https://www.energypelletsamerica.com/product/1-ton-pallet-fuel-pellets/> [accessed March 2020].

- Ericsson, K., & Werner, S. 2016. The Introduction and Expansion of Biomass Use in Swedish District Heating Systems. *Biomass and Bioenergy*, Volume 94, 57–65. <https://core.ac.uk/reader/82814720> [accessed March 2020].
- Ewanick, S., & Bura, R. 2016. A New Approach to Using Dried Hybrid Poplar as a Potential Commodity Feedstock for Sugar Production. *ACS Sustainable Chemistry & Engineering*, Volume 4, Issue 8: 4378–4384.
- Forest2Market. 2018. Chip & Pulpwood Price Trends in the US South & PNW. <https://www.forest2market.com/blog/chip-pulpwood-price-trends-in-the-us-south-pnw> [accessed March 2020].
- Forest2Market. 2020 How Many Tons of Wood Are on an Acre of Land? <https://www.forest2market.com/blog/how-many-tons-of-wood-are-on-an-acre-of-land> [accessed March 2020].
- Genera. 2020. Short Rotation Woody Crops. <https://generainc.com/short-rotation-woody-crops/> [accessed February 2020].
- GRACE. 2019. Growing Advanced Industrial Crops on Marginal Lands for Bio-Refineries. GRACE Project, University of Hohenheim. <https://www.grace-bbi.eu/project/> [accessed March 2020].
- Heaton et al. 2010. Miscanthus: A Promising Biomass Crop. *Advances in Botanical Research*, Volume 56, pp. 75–137. Heaton, Emily A., Dohleman, Frank G., Miguez, A. Fernando, Juvik, John A., Lozovaya, Vera, Widholm, Jack, Zobotina, Olga A., et al. Academic Press, 2010.
- Heavey. 2016. *Annual Report 2016: Project Area 10: New York State Shrub Willow*. Biomass Crop Assistance Program, U.S. Department of Agriculture. Heavey, J., Volk, T., & Buckley, M. <https://www.esf.edu/willow/documents/2016WillowBCAPAnnualReport.pdf> [accessed March 2020].
- Hedrick, T. 2017. *Mechanical Planting & Alternative Uses in the "Miscanthus Field."* Repeve Renewables. <http://www.ncagr.gov/bioenergy/Highlights.htm> [accessed March 2020].
- Hoque. 2014. *Estimated Cost of Establishment and Production of Miscanthus in Iowa*. Iowa State University Extension and Outreach Ag Decision Maker, A1–28. Hoque, M., Artz, G., & Hart, C. <https://www.extension.iastate.edu/agdm/crops/pdf/a1-28.pdf> [accessed March 2020].
- Inbicon. 2012. *Inbicon Biomass Refinery: Cellulosic Ethanol Technology Platforms, Growth and Sustainability Through Biomass Refining, CHP: Technology Review*. https://www.eia.gov/biofuels/workshop/pdf/paul_kamp.pdf [accessed March 2020].
- Iowa Now. 2017. UI Announces It Will Be Coal-Free by 2025. University of Iowa – Iowa Now. <https://now.uiowa.edu/2017/02/ui-announces-it-will-be-coal-free-2025> [accessed March 2020].
- Iowa Now. 2019. UI moves to next step in exploring public-private partnership with utility system. University of Iowa – Iowa Now. <https://now.uiowa.edu/2019/07/next-step-p3> [accessed June 2020].
- Jackson. 2018. Woody Biomass Processing: Potential Economic Impacts on Rural Regions. *Energy Policy*, Volume 115, 66–77. Jackson, R. W., Neto, A. B. F., & Erfanian, E.
- Jacobson, M. 2013. *Miscanthus Budget for Biomass Production*, Renewable and Alternative Energy Fact Sheet. Penn State Cooperative Extension. <https://extension.psu.edu/miscanthus-budget-for-biomass-production> [accessed March 2020].
- Jacobson, M. 2014. *Shrub Willow Budget for Biomass Production*, Renewable and Alternative Energy Fact Sheet. Penn State Cooperative Extension. https://extension.psu.edu/downloadable/download/sample/sample_id/686/ [accessed March 2020].
- Kells, B. J., & Swinton, S. M. 2014. Profitability of Cellulosic Biomass Production in the Northern Great Lakes Region. *Agronomy Journal*, Volume 106, Issue 2. <https://access.onlinelibrary.wiley.com/doi/pdf/10.2134/agronj2013.0397> [accessed March 2020].
- Khanna. 2008. Costs of Producing Miscanthus and Switchgrass for Bioenergy in Illinois. *Biomass and Bioenergy*, Volume 32, Issue 6, 482–493. Khanna, M., Dhungana, B., & Clifton-Brown, J.
- Lee et al. 2018. Biomass Production of Herbaceous Energy Crops in the United States: Field Trial Results and Yield Potential Maps From the Multiyear Regional Feedstock Partnership. *Global Change Biology*, No. 10, 698–716. Lee, Do Kyoung, Aberle, Ezra, Anderson, Eric K., Anderson, William, Baldwin, Brian S., Baltensperger, David, Barrett, Michael, et al. <https://onlinelibrary.wiley.com/doi/pdf/10.1111/gcbb.12493> [accessed March 2020].
- Lewandowski et al. 2016. Progress on Optimizing Miscanthus Biomass Production for the European Bioeconomy: Results of the EU FP7 Project OPTIMISC. *Frontiers in Plant Science*, Volume 7, Article 1620. Lewandowski, I., Clifton-Brown, J., Trindade, L. M., van der Linden, G. C., Schwarz, K. U., Müller-Sömann, K., ... & Farrar, K. https://pdfs.semanticscholar.org/59ad/72de392f9f1619225121dfaab2b94722b6e8.pdf?_ga=2.38095845.730790991.1585851197-1777513571.1585764446 [accessed March 2020].
- Liu et al. 2017. Economic and Life Cycle Assessments of Biomass Utilization for Bioenergy Products. *Biofuels, Bioproducts and Biorefining*, Volume 11, No. 4, 633–647. Liu, Weiguo, Wang, Jingxin, Richard, Tom L., Hartley, Damon S., Spataro, Sabrina, & Volk, Timothy A.
- Mid-Kansas Electric. 2010. Abengoa Bioenergy and Mid-Kansas Electric Reach Agreement Concerning First Commercial-Scale Hybrid Cellulosic Ethanol and Power Plant in U.S. Partnership to Diversify Kansas' Electric Generation and Promote

- Energy Independence. Global Newswire. <http://www.globenewswire.com/fr/news-release/2010/01/19/412515/182207/en/Abengoa-Bioenergy-and-Mid-Kansas-Electric-Reach-Agreement-Concerning-First-Commercial-Scale-Hybrid-Cellulosic-Ethanol-and-Power-Plant-in-U-S.html> [accessed March 2020].
- Missouri. 2017. *Wood Fuel for Heating*. University of Missouri Extension. <http://extension.missouri.edu/publications/DisplayPrinterFriendlyPub.aspx?P=g5450> [accessed March 2020].
- Mitchell et al. 2014. *Switchgrass*. University of Nebraska – Lincoln/USDA, Agriculture Research Service. Mitchell, Robert B., Lee, D. K., & Casler, Michael. https://digitalcommons.unl.edu/usdaarsfacpub/1438?utm_source=digitalcommons.unl.edu%2Fusdaarsfacpub%2F1438&utm_medium=PDF&utm_campaign=PDFCoverPages [accessed March 2020].
- OMAFRA. 2020. *Biomass Burn Characteristics*. Ontario Ministry of Agriculture, Food and Rural Affairs. <http://www.omafra.gov.on.ca/english/engineer/facts/11-033.htm> [accessed March 2020].
- Oswego County. 2019. *Attis CEO: Volney Ethanol Plant an "Incredible Opportunity" for Both Company and Community*. Oswego County News Now. https://www.oswegocountynewsnow.com/columnists/attis-ceo-volney-ethanol-plant-an-incredible-opportunity-for-both/article_005b7e54-9367-11e9-934c-47bb41d0c931.html [accessed March 2020].
- Penn State Extension. 2014. *On-Farm Production of Biomass Grass Pellets: A Case Study*. <https://extension.psu.edu/on-farm-production-of-biomass-grass-pellets-a-case-study> [accessed March 2020].
- Perrin et al. 2008. *Farm-Scale Production Cost of Switchgrass for Biomass*. *BioEnergy Research*, Volume 1, Issue 1, 91–97. Perrin, R., Vogel, K., Schmer, M., & Mitchell, R. <https://link.springer.com/article/10.1007/s12155-008-9005-y> [accessed March 2020].
- Prairie Lands. 2020. *Prairie Lands Biomass Project: Home Grown Energy*. <https://www.iowaswitchgrass.com/about.html> [accessed March 2020].
- Renewable Energy World. 2013. *Is Shrub Willow a Viable Biomass Feedstock for the US?* Dorminey, B. November 14, 2013. <https://www.renewableenergyworld.com/2013/11/14/is-shrub-willow-a-viable-biomass-feedstock-in-the-us/> [accessed March 2020].
- Rokwood. 2015. *Energy Crops in Europe: Best Practice in SRP Biomass From Germany, Ireland, Poland, Spain, Sweden & UK*. <https://www.cse.org.uk/downloads/reports-and-publications/renewables/energy-crops-in-europe-rokwood-2015.pdf> [accessed March 2020].
- Scarlat et al. 2015. *The Role of Biomass and Bioenergy in a Future Bioeconomy: Policies and Facts*. European Commission, Joint Research Centre, Via E. Fermi 2749—TP 450,21027 Ispra, VA, Italy. Scarlat, N., Dallemand, J-F., Monforti-Ferrario, F., & Nita, V. <https://www.sciencedirect.com/science/article/pii/S2211464515000305> [accessed May 2020].
- Ssegane et al. 2016. *The Economics of Growing Shrub Willow as a Bioenergy Buffer on Agricultural Fields: A Case Study in the Midwest Corn Belt*. *Biofuels, Bioproducts and Biorefining*, Volume 10, Issue 6, 776–789. Ssegane, H., Zumpf, C., Cristina Negri, M., Campbell, P., Heavey, J. P., & Volk, T. A. <https://onlinelibrary.wiley.com/doi/pdf/10.1002/bbb.1679> [accessed March 2020].
- Stanton et al. 2019. *The Economics of Rapid Multiplication of Hybrid Poplar Biomass Varieties*. Stanton, Brian J., Kathy Haiby, Carlos Gantz, Jesus Espinoza, and Richard A. Shuren. *Forests* 10, No. 5 (2019): 446. <https://www.mdpi.com/1999-4907/10/5/446/htm> [accessed March 2020].
- Eisenbies et al. 2014. *Development and Deployment of a Short Rotation Woody Crops Harvesting System Based on a Case New Holland Forage Harvester and SRC Woody Crop Header*. State University of New York College of Environmental Science and Forestry. Eisenbies, M., Volk, T., Abrahamson, L., Shuren, R., Stanton, B., Posselius, J., McArdle, M., Karapetyan, S., Patel, A., Shi, S., Zerpa, J. <https://www.osti.gov/servlets/purl/1164395> [accessed February 2021].
- Townsend, et al. 2018. *A Roadmap for Poplar and Willow to Provide Environmental Services and to Build the Bioeconomy*. Washington State University Extension. Townsend, P., Haider, N., Boby, L., Heavey, J., Miller, T. A., Volk, T. <https://research.wsulibs.wsu.edu/xmlui/handle/2376/13222> [accessed June 2020].
- University of Iowa. 2019a. *Biomass Fuel Project*. <https://sustainability.uiowa.edu/campus-initiatives/energy/biomass-fuel-project> [accessed March 2020].
- University of Iowa. 2019b. *Renewable Energy*. <https://www.facilities.uiowa.edu/energy-environment/renewable-energy> [accessed March 2020].
- USDA, 2010. *Pennsylvania Natural Resources Conservation Service Flickr*. <https://www.flickr.com/photos/pa-nrcs/15257727546/in/photolist-pfgQQ3-dkM2kr-dkM4oA-dkM2pX-2946wh-Vu9gmJ-VSJNP4-8MZTgV-UMXYvJ-UQH2ZZ/> [accessed February 2021].
- USDA, 2011. *Coppice Regrowth*. U.S. Department of Agriculture National Institute of Food and Agriculture. <https://hardwoodbiofuels.org/resources/gallery/coppice-regrowth/> [accessed February 2021].
- USDA. 2017. *Dedicated Energy Crops and Competition for Agricultural Land*. U.S. Department of Agriculture, Economic Research Service, ERR-223. Sands, Ronald D., Malcolm, Scott A., Suttles, Shellye, A., & Marshall, Elizabeth. <https://www.ers.usda.gov/webdocs/publications/81903/err-223.pdf?v=0> [accessed March 2020].

- USDA. 2018a. Switchgrass. U.S. Department of Agriculture. <https://www.agmrc.org/commodities-products/biomass/switchgrass> [accessed March 2020].
- USDA. 2018b. Miscanthus Profile. U.S. Department of Agriculture. <https://www.agmrc.org/commodities-products/biomass/miscanthus-profile> [accessed March 2020].
- USDA. 2019a. Poplar (*Populus spp.*) Trees for Biofuel Production. U.S. Department of Agriculture, National Institute of Food and Agriculture. <https://farm-energy.extension.org/poplar-populus-spp-trees-for-biofuel-production/> [accessed March 2020].
- USDA. 2019b. U.S. Department of Agriculture, National Agricultural Statistics Service. <https://quickstats.nass.usda.gov/results/C77C3D76-7B56-3B06-8D11-EC34BC546404> [accessed March 2020].
- USDA. 2019c. U.S. Department of Agriculture, National Agricultural Statistics Service. <https://quickstats.nass.usda.gov/results/70819994-86C1-3C64-96EF-2965BD92C9C6> [accessed March 2020].
- USDA. 2019d. *Oil Crops Yearbook*, U.S. Department of Agriculture, Economic Research Service. <https://www.ers.usda.gov/data-products/oil-crops-yearbook/> [accessed March 2020].
- USDA. 2019e. *ReEnergy Holdings: Offering Markets for Biomass in the Northeast*. U.S. Department of Agriculture, National Institute of Food and Agriculture. <https://farm-energy.extension.org/reenergy-holdings-offering-markets-for-biomass-in-the-northeast/> [accessed March 2020].
- USDA. 2019f. *Switchgrass (*Panicum virgatum*) for Biofuel Production*. U.S. Department of Agriculture, National Institute of Food and Agriculture. <https://farm-energy.extension.org/switchgrass-panicum-virgatum-for-biofuel-production/> [accessed March 2020].
- USDA. 2019g. *Miscanthus (*Miscanthus x giganteus*) for Biofuel Production*. U.S. Department of Agriculture, National Institute of Food and Agriculture. <https://farm-energy.extension.org/miscanthus-miscanthus-x-giganteus-for-biofuel-production/> [accessed March 2020].
- USDA. 2019h. U.S. Department of Agriculture National Agricultural Statistics Service. <https://quickstats.nass.usda.gov/data/maps/72D17BCE-0350-3FC9-BAAA-159D32EE3D74> [accessed March 2020].
- USDA. 2019i. U.S. Department of Agriculture, National Agricultural Statistics Service. https://quickstats.nass.usda.gov/13C6E1A4-EAFA-382A-A861-66BE98A68CEF?long_desc__LIKE=switchgrass [accessed March 2020].
- USDA. 2019j. U.S. Department of Agriculture, National Agricultural Statistics Service. https://quickstats.nass.usda.gov/13C6E1A4-EAFA-382A-A861-66BE98A68CEF?long_desc__LIKE=miscanthus [accessed March 2020].
- USDA. 2020a. *Woody Biomass Utilization and the WBUG*. U.S. Department of Agriculture, Forest and Rangelands. <https://www.forestsandrangelands.gov/woody-biomass/overview.shtml> [accessed March 2020].
- USDA. 2020b. U.S. Department of Agriculture, National Agricultural Statistics Service, Census of Agriculture. <https://www.nass.usda.gov/AgCensus/> [accessed May 2020].
- USDA. 2020c. Conservation Reserve Program, U.S. Department of Agriculture, Farm Service Agency. <https://www.fsa.usda.gov/programs-and-services/conservation-programs/conservation-reserve-program/> [accessed May 2020].
- USGOV. 2016. *United States Mid-Century Strategy for Deep Decarbonization*. The White House. https://unfccc.int/files/focus/long-term_strategies/application/pdf/mid_century_strategy_report-final_red.pdf [accessed June 2020].
- Volk et al. 2014. *Shrub Willow Renewable Energy Environmental Benefits*. The Research Foundation for the State University of New York, College of Environmental Science and Forestry, Syracuse, NY. Volk, Timothy A., & Heavey, Justin P. <https://www.esf.edu/willow/> [accessed May 2020].
- Volk et al. 2016. *Advances in Shrub-Willow Crops for Bioenergy, Renewable Products, and Environmental Benefits*. State University of New York, College of Environmental Science and Forestry, Syracuse, NY. Volk, Timothy A., Heavey, Justin P., & Eisenbies, Mark H. <https://onlinelibrary.wiley.com/doi/epdf/10.1002/fes3.82> [accessed May 2020].
- Volk et al. 2018. *Poplar and Shrub Willow Energy Crops in the United States: Field Trial Results From the Multiyear Regional Feedstock Partnership and Yield Potential Maps Based on the PRISM-ELM Model*. *GCB Bioenergy*, Volume 10, No. 10, 735–751. Volk, Timothy A., Berguson, Bill, Daly, Christopher, Halbleib, Michael D., Miller, Raymond, Rials, Timothy G., Abrahamson, Lawrence P., et al. <https://onlinelibrary.wiley.com/doi/pdf/10.1111/gcbb.12498> [accessed March 2020].
- Walling, G. A. 2005. *Global Climate & Energy Project*. Advanced Coal Workshop, March 15 & 16. http://gcep.stanford.edu/pdfs/RxsY3908kaqwVPacX9DLcQ/walling_coal_mar05.pdf [accessed March 2020].
- Watts & Associates. 2011. *Data Collection Report for Woody Biomass Products and a Feasibility Research Report for Insuring Fast Growing Trees (Such as Poplar & Willow) and Other Woody Biomass Products – Deliverable 1: Data Collection Report for Woody Biomass Products*. <https://legacy.rma.usda.gov/pubs/2011/biomass.pdf> [accessed March 2020].



Williams et al. 2018. Preprocessing and Hybrid Biochemical/Thermochemical Conversion of Short Rotation Woody Coppice for Biofuels. *Frontiers in Energy Research*, July 2018, Volume 6, Article 74. Williams, C. L., Emerson, R. M., Hernandez, S., Klinger, J. L., Fillerup, E. P., & Thomas, B. J. <https://www.frontiersin.org/articles/10.3389/fenrg.2018.00074/full> [accessed March 2020].

Witzel, C. P., & Finger, R. 2016. Economic Evaluation of Miscanthus Production – A Review. *Renewable and Sustainable Energy Reviews*, Volume 53, 681–696. <https://doi.org/10.3929/ethz-b-000108799> [accessed March 2020].

9. Wood Pellets and Wood Chips

INTRODUCTION

This chapter discusses the use of wood chips and wood pellets as feedstocks to produce renewable heat and power. Wood has been used for cooking, heat, and light for thousands of years and was the primary source of energy in the world until the mid-1800s. In 2018, approximately 2 percent of energy in the United States was supplied from wood and wood waste (EIA, 2019).

Wood chips and wood pellets are derived from basically the same resource. Virtually all wood chips used for energy are combusted, either directly or after conversion to pellets. A small proportion of chips are used as feedstock for various liquid and gaseous fuels. Wood pellets also are combusted directly to generate heat, steam, and/or power.

Key Takeaways on Wood Chips

1. Most wood chips produced in the United States are either used for paper and other manufactured wood products, or for wood pellets. Roughly half of the portion not used for paper production are used for pellets.
2. The market for chips for the paper industry is likely to shrink in the near term, while the market for chips for utility pellet production will likely increase.
3. As with wood pellets, the production levels of wood chips are highest in the Southeast.
4. With respect to energy production, most wood chips are directly combusted. A small amount of wood chips are converted to liquid and gaseous fuels; however, these products are not yet fully commercialized.

Key Takeaways on Wood Pellets

1. There are two distinct markets for wood pellets in the United States—one for fuel in residential heating stoves and the other for combustion in utility-scale facilities to produce heat, steam, and power for grid or industrial uses.
2. Virtually all utility-grade pellets produced in the United States are exported. The export market is expected to expand over time.
3. At present, there is little excess utility-grade pellet production capacity; however, there may be some excess seasonal production capacity for mills that produce residential heating pellets.
4. Most utility-grade pellets are produced in large facilities in the Southeastern United States, while heating pellet production is more widely distributed throughout the country.

This chapter describes the uses of wood chips and wood pellets; their availability; locations favorable to availability; and production costs and potential environmental impacts.

RENEWABLE ENERGY USES

Wood Chips

Wood chips are small to medium-sized pieces of residual wood formed by cutting or chipping larger pieces of wood and wood waste. The predominant uses of wood chips in the United States are for paper, wood products, and wood pellets (Edwards, 2019). Approximately half of all wood chips in the United States not used for paper production are used for pellets. The demand for wood chips used for pellet manufacturing is growing and will soon surpass other wood chip demands (Edwards, 2019).

Wood chips are generally produced from round wood (i.e., logs stripped of bark), wood residues (i.e., logging residues, wood from forest thinning operations, stumps, roots, and other wood waste), and construction debris; however, limited information is available about the quantities or quality from these sources. Raw material is mechanically processed into chips using chippers either on-site (i.e., in the forest); in dedicated chip manufacturing facilities; or in saw, pulp, paper, or pellet mills. *Exhibit 9-1* is a large industrial mobile chipper.

Chips are produced to have somewhat uniform thickness and certain maximum overall dimensions, which can be varied with knife adjustments and chip screening, depending on end-use. For example, chips used for Kraft pulping and other chemical processes are typically less than 0.75 to 1 inch in width and length, and 0.12 inch thick.²⁶² Such processes require relatively uniform chip thickness to allow uniform chemical penetration (BERC, 2019). Wood chips used for combustion might be as large as 3 inches by 3 inches by 0.5 inches thick, depending on the fuel handling system and the combustion equipment.

Wood chips can be utilized as a renewable energy source through direct combustion, and to a more limited extent, conversion to liquid and gaseous fuels (i.e., diesel, ethanol, jet fuel, and biomethane). The following sections provide a brief overview of some of those conversion technologies and their relative level of maturity.

Direct Combustion

Wood chips can be burned directly for heat in wood chip burners for residential or industrial use. More commonly, wood chips are used in solid fuel boilers to produce heating steam, processing steam, and/or power for industrial applications. Traveling and vibrating grate boilers are typical boiler types that are used for this type of solid fuel. Wood chips can also be converted to wood pellets that can be directly combusted. Both residential and industrial wood combustion are mature and fully commercialized technologies. An example of typical pulpwood chips is depicted in *exhibit 9-2*.

Other Conversion Processes

There are several processes at various stages of maturity that can convert biomass to liquid and gaseous fuels or fuel precursors. These can be chemical, thermal, and/or biological processes such as hydrothermal liquefaction, pyrolysis, gasification with gas to liquid conversion (both catalytic and biological), and hydrothermal catalytic gasification for the production of bioethanol, jet fuel, diesel, gasoline, and renewable natural gas. These processes are described briefly below. More details are provided in chapter 7, *Biodiesel and Renewable Diesel*, of this report.

EXHIBIT 9-1: Mobile Forest Chipper Used to Create Wood Chips



Source: USDA, 2016.

EXHIBIT 9-2: Typical Pulpwood Chips



²⁶² Kraft pulping is a chemical process for the production of wood pulp that employs a caustic soda and sodium sulfide liquor to cook pulpwood in order to separate lignin from wood fibers.

Gasification

Biomass can be converted to a fuel through a biomass gasification process, which involves partial oxidation of the feedstock at a high temperature (> 800 degrees Celsius [°C]). This gas, commonly called “producer gas” or “syngas,” contains hydrogen, carbon monoxide, carbon dioxide, methane, and trace amounts of higher hydrocarbons (e.g., ethane). Syngas can be used as boiler, engine, and turbine fuels, or for conversion to liquid fuels and chemicals such as methanol, ethanol, gasoline, diesel and jet fuel, and high-value wax. There are currently some gasification liquid fuel conversion technologies that are in the early-stage commercial or pioneer facility stage of maturity. There are others that are in the pilot stage of development.

Pyrolysis

Pyrolysis is the thermal decomposition of wood in the absence of oxygen, which occurs between 400°C and 800°C. Pyrolysis breaks down wood to condensable vapors, non-condensable gases (pyrolysis gas), and char. The pyrolysis gas contains carbon monoxide, carbon dioxide, hydrogen, methane, and higher hydrocarbons. The condensable vapors are cooled to form a liquid known as “bio-oil” or “pyrolysis liquid,” which contains a wide range of oxygenated chemicals and water. All of these products are combustible for energy. Pyrolysis has long been applied in a variety of industrial applications. Pyrolysis for conversion of wood chips to fuels is in the early-stage commercial or pioneer facility stage of maturity.

Hydrothermal Liquefaction and Catalytic Hydrothermal Gasification

Hydrothermal liquefaction (HTL) is also a thermal decomposition process to convert wet biomass, including shredded wood, into a substance referred to as “biocrude.” The process occurs at a moderate temperature (~300°C) and high pressure (> 2,500 pounds per square inch). Water is separated from the biocrude, which is then upgraded to diesel-range fuel. The residual water can be processed with catalytic hydrothermal gasification (CHG) to convert the organics remaining in the water to methane, which can be directly burned or further purified for injection into a natural gas pipeline. HTL and CHG processes have been demonstrated at laboratory and pilot scales but are not yet commercially available (Billing et al., 2017).

Hydrolysis

Hydrolysis of wood and woody biomass is the conversion of cellulose and hemicellulose to fermentable sugars. The sugars can then be converted directly to ethanol or other chemicals via fermentation. Hydrolysis of feedstocks such as corn stover is well-developed, while the conversion of wood has not yet proven to be economical due to the relatively high dosing rates of enzymes required to drive the process.²⁶³

EXHIBIT 9-3: Pellets Made From Dried, Shredded, and Compressed Wood That Can Be Used as a Fuel

Wood Pellets

Wood pellets are a solid fuel made from dried, shredded, and compressed wood that can be used for residential and utility or industrial applications. *Exhibit 9-3* depicts both pellets and one common form of wood from which pellets can be made. For residential applications, wood pellets are generally combusted in a stove designed to produce heat for comfort and, in some cases, heat for cooking. Utilities or industrial facilities may use wood pellets in solid-fuel boilers to produce steam for heating, process steam, or power. Feedstocks may consist of recycled wood chips



²⁶³ For more information on corn stover and hydrolysis, see chapters 6 and 8, respectively, in this report.

or residues captured from other wood product manufacturing processes (i.e., saw dust from lumber mills, forest residuals, and from logs). An increasingly large percentage of these residual feedstocks are sourced from tree farms specifically stocked with fast-growing trees and managed to supply biomass to the energy, paper, and harvested wood product markets.

Residential Heating Pellets

As of September 2018, U.S. residential heating pellet capacity was 5.5 million metric tons (6.1 million short tons) per year (Portz, 2018). Facilities that manufacture residential heating pellets are typically smaller in scale (i.e., have annual production capacities of less than 150,000 metric tons [165 short tons]) than facilities that manufacture utility-grade pellets. Additionally, plants that produce residential heating pellets generally operate at 55 percent to 60 percent of capacity due to seasonal fluctuations in demand (Portz, 2018). This means that the industry could scale up production by using existing facilities more intensely should the demand for residential wood pellets increase.

As shown in *Exhibit 9-4*, several States have put in place programs and/or policies that incentivize the demand for residential wood pellets.

EXHIBIT 9-4: State and Local Agency Pellet Stove Incentives

State	Incentive Name	Incentive Details
Maine	<i>Biomass Boilers and Furnaces</i>	Homeowners are eligible for a rebate of one-third of project costs up to \$6,000 for eligible biomass boilers and furnaces with enough capacity for at least 2 weeks of unattended operation (Efficiency Maine, 2019).
Maryland	<i>Clean Burning Wood and Pellet Stove Grant Program</i>	Homeowners are eligible for a rebate of up to \$500 for a new wood-burning stove and up to \$700 for a new pellet-burning stove that displaces electric, non-natural gas fossil fuel heating systems, or old woodstoves (Maryland Energy Administration, 2019).
Massachusetts	<i>Commonwealth Woodstove Change-Out</i>	Homeowners are eligible for a rebate of \$500 to \$1,750 (standard) or \$2,000 to \$3,250 (low-income) to change out old woodstoves that are currently operational and non-U.S. Environmental Protection Agency (EPA) certified to an EPA-certified stove that meets emission requirements (Massachusetts Clean Energy Center, 2019).
Montana	<i>Energy Tax Credits, Biomass (Wood) Stoves</i>	A Montana State credit of up to \$500 per taxpayer exists for appliances that meet EPA standard 40 Code of Federal Regulations 60.533. Any new wood pellet stove qualifies for the \$500 Montana credit (Montana Department of Environmental Quality, 2017).
New York	<i>Residential Pellet Stove, Incentives and Financing</i>	Homeowners are eligible for an incentive of \$1,500 for the purchase of a new pellet stove with the recycling of an existing wood, pellet stove, or insert (with firebox) in a primary residence. Households with an income up to 80 percent of the State or county median (whichever is greater) may qualify for an incentive of up to \$2,000 for the purchase of a new pellet stove in a primary residence, and an additional \$500 if an existing wood, pellet stove, or insert (with firebox) is recycled (NYSERDA, 2019).
Vermont	<i>Renewable Energy Resource Center/Clean Energy Development Fund (RERC/CEDF) Wood Stove Incentive</i>	Homeowners are eligible for \$1,000 for a new pellet stove or \$800 for a new cord wood stove that replaces a non-EPA certified stove. Customers are also eligible for a \$100 incentive to replace the catalyst in an existing EPA-certified wood stove (Vermont Energy Investment Corporation, 2018).
	<i>Efficiency Vermont and CEDF, Residential Rebates and Incentives</i>	Homeowners are eligible for a \$3,000 purchase rebate and a \$3,000 installer incentive for high-efficiency wood pellet furnaces and boilers installed as a primary central heating system in spaces of up to 5,000 square feet (Efficiency Vermont, 2019).
	<i>Windham County Wood Pellet Heat Program</i>	Homeowners can trade in their old wood stove, or propane or kerosene heater and receive \$2,000 to \$4,000 toward the cost of a clean-burning, energy-efficient pellet stove (Windham & Windsor Housing Trust, 2019).
Washington	<i>Puget Sound Wood Stove Program</i>	Residents of King, Kitsap, Pierce, and Snohomish counties are eligible to receive \$350 for recycling a wood stove manufactured before 2000 or which is not EPA certified. Residents are eligible for a \$1,500 discount toward the purchase of new heating equipment, including pellet stoves (Puget Sound Clean Air Agency, 2019).

At the Federal level, there was also the 2014 Biomass Heating Tax Credit to incentivize residential pellet fuel, which has expired and has not been renewed. This Federal measure provided a \$300 tax credit for residential biomass heating equipment (Energy Star, 2018).

In addition to Federal and State incentives, U.S. demand for residential wood pellets has been driven by its regional competitive price advantages versus fuel oil, propane, and natural gas as a substitute for heating oil. Unlike with utility-grade pellets, there is greater geographic diversity in residential pellet manufacturing, with States in the Mid-Atlantic, Midwest, and Northeast leading production. In recent years, however, growth in these regional markets has been limited by the expansion of the natural gas pipeline network (which, has made natural gas a cost-competitive alternative to wood pellets as a heating fuel).

Utility-Grade Pellets

Utility-grade pellets are produced primarily from whole logs, forest residues, thinnings, treetops and limbs, and low-quality fiber that lack other markets. Industrial-grade utility pellet mills are typically larger than residential pellet facilities, with capacities of 150,000 metric tons (165,350 short tons) per year or greater, and almost all operate at or near full capacity (Portz, 2018). In general, the industrial-grade pellet mills have pellet off-take contracts that were put in place to obtain investor and bank funding to build the facilities.

The primary consumers of U.S. pellets are export markets, which accounted for more than two-thirds of U.S. production in 2015 (Idaho National Laboratory, 2017). In recent years, the global market for utility-grade pellets has grown about 10 percent per year. This trend is expected to continue, at least in the near term (Canadian Biomass Magazine, 2017). The key factor driving increasing demand for utility-grade pellets is the Renewable Energy Directive of the European Union (EU), which mandates that a **percentage of each Member State's energy be generated using renewable sources**. The original directive (2009/28/EC) required the EU to fulfill at least 20 percent of its total energy needs with renewables by 2020. It specified national renewable energy targets for each country, taking into account its starting point and overall potential for renewable energy use. These targets ranged from a low of 10 percent in Malta to a high of 49 percent in Sweden (Abt et al., 2014). This directive resulted in more than a fourfold increase in overall U.S. wood pellet production and export between 2008 and 2013 (Abt et al., 2014). The directive, however, is an ongoing process and there have been follow-on proposals to extend and increase the renewable energy mandate through 2030. In December 2018, a revised Renewable Energy Directive (2018/2001/EU) entered into force, establishing a new binding renewable energy target of 32 percent for the EU by 2030 (European Commission, 2020). This revised mandate is likely to increase European demand for U.S. wood chips and pellets. U.S. production could increase to meet this demand by expanding production capacity, most likely in the Southeast. Without additional Federal, State, or other incentives, and new regulations that motivate utilities and industry to switch to pellet fuel, there will be little growth in domestic demand for pellets.

Exhibit 9-5 shows global consumption (domestic production and imports), along with exports of wood pellets for specific countries in calendar year 2015–2016 (Thrän, et. al., 2018).

EXHIBIT 9-5: Global Domestic Consumption (Domestic Production and Import) and Exports per Country for Chosen Countries in 2015–2016*

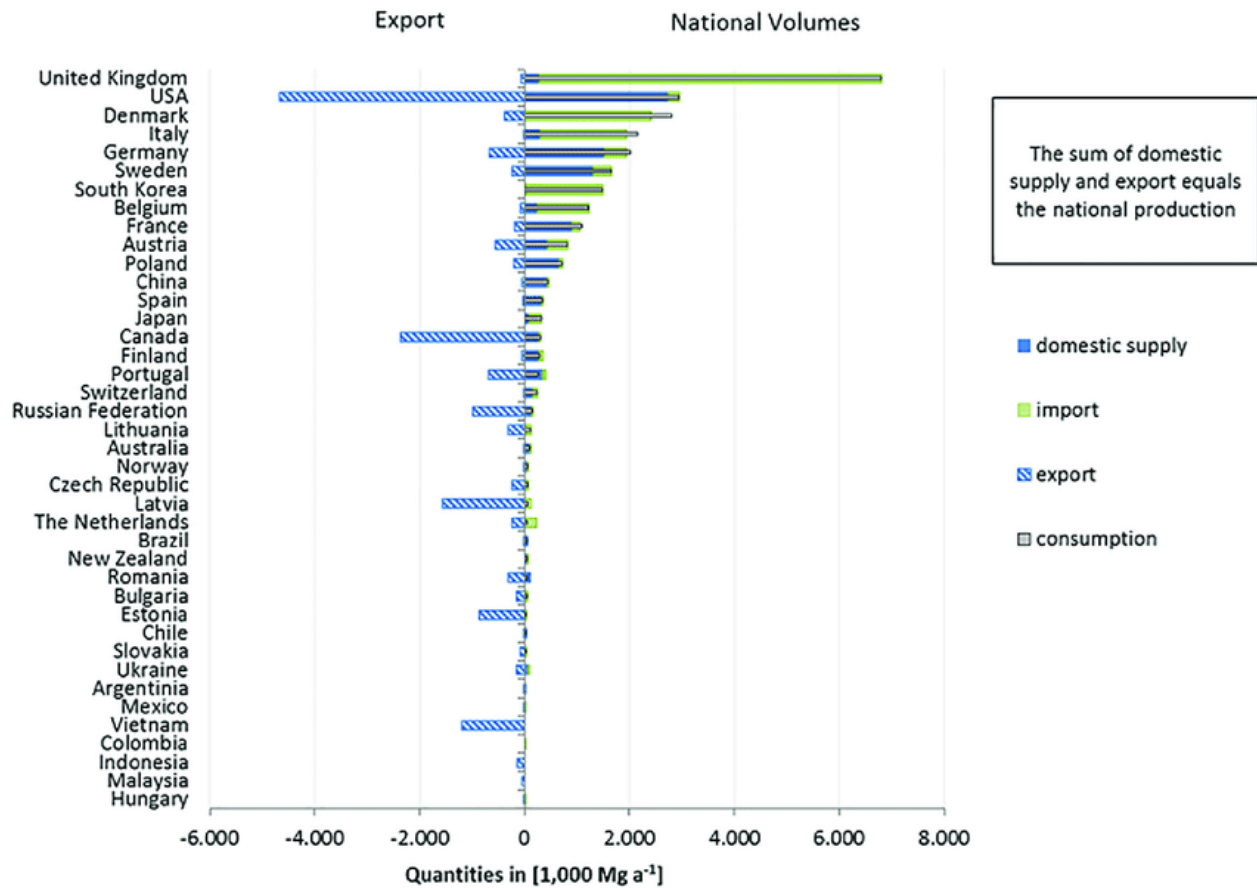

* Country exports and imports reflect calendar year 2015–2016; values are reported in metric tons. Source: Thrän, et. al., 2018.

Exhibit 9-6 shows global consumption of industrial and residential wood pellets, and exports of wood pellets by country for calendar year 2015–2016. It shows that U.S. domestic consumption of industrial pellets is virtually zero, and again highlights the U.S. role as the leading exporter of wood pellets. The three largest importers of U.S. pellets are the United Kingdom, Belgium, and Denmark.

EXHIBIT 9-6: Wood Pellet Consumption and Exports for 2015–2016

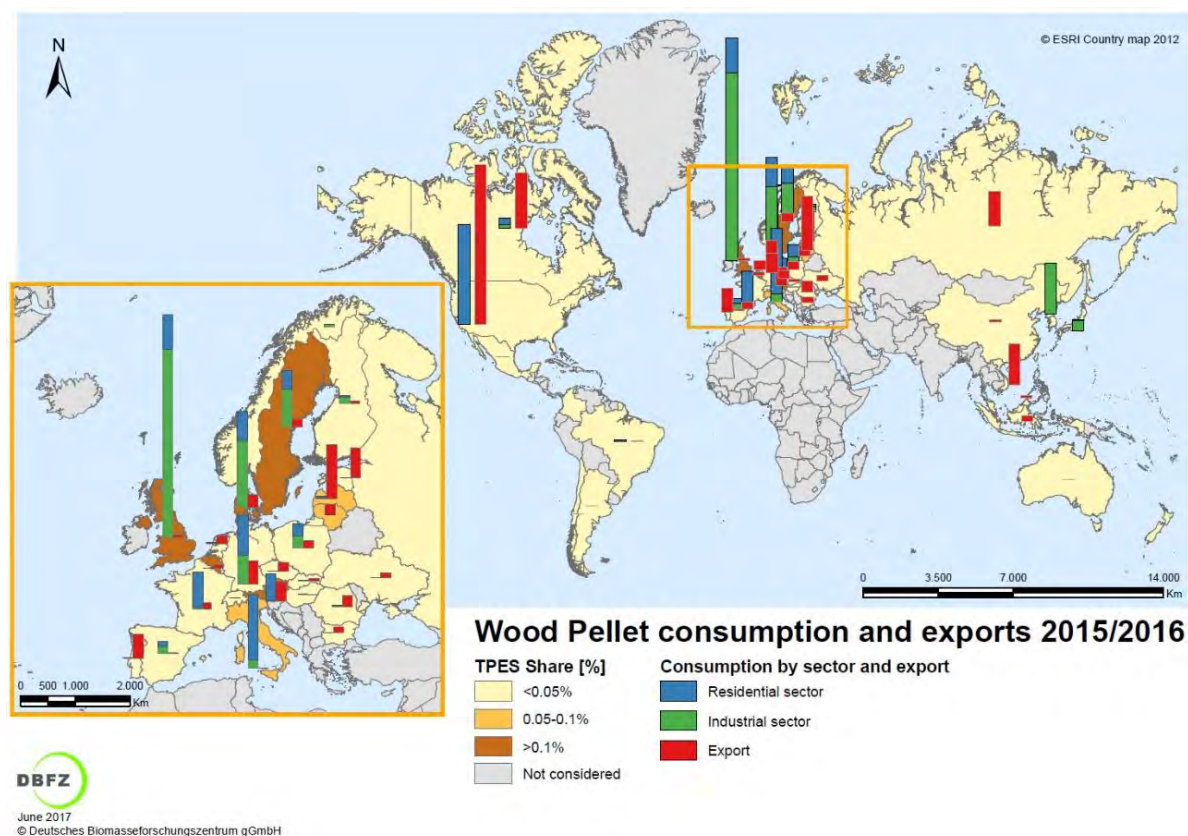

TPES: Total Primary Energy Supply
Source: DBFZ, 2017.

AVAILABILITY OF WOOD PELLETS AND WOOD CHIPS

The geographic distribution of wood chip and wood pellet production coincides with regional resource availability. Since wood chips and wood pellets are derived from essentially the same resource, the following discussion related to the availability of woody biomass feedstocks is pertinent to both products.

Wood production is scattered throughout the United States but has historically been greatest in the Pacific Northwest and the Southeast. *Exhibit 9-7* shows projected forest resources for 2040 for a roadside price of \$60/dry ton or less. The projection assumes a scenario where production is from both Federal and private lands. The roadside price does not include transportation from the point of harvest to the end-user.

According to the 2016 Billion-Ton Report from the U.S. Department of Energy (DOE), there are currently 31 million short tons/year of unused wood chips at a cost of greater than \$100/ton that may be available as a feedstock. The report indicates that unused chip availability is expected to grow to 84 million tons/year in the long term. The DOE quantified potential forest woody biomass resources. At prices of up to \$60/dry ton, the report projected that 103 million and 97 million tons/year of biomass resources are potentially available from forestlands in 2017 and 2040, respectively, in a “base-case scenario” (i.e., all timberland, including Federal lands) (DOE, 2016).

EXHIBIT 9-7: Forest Resource Totals, 2040 (< \$60/dry ton [dt] Roadside Price)

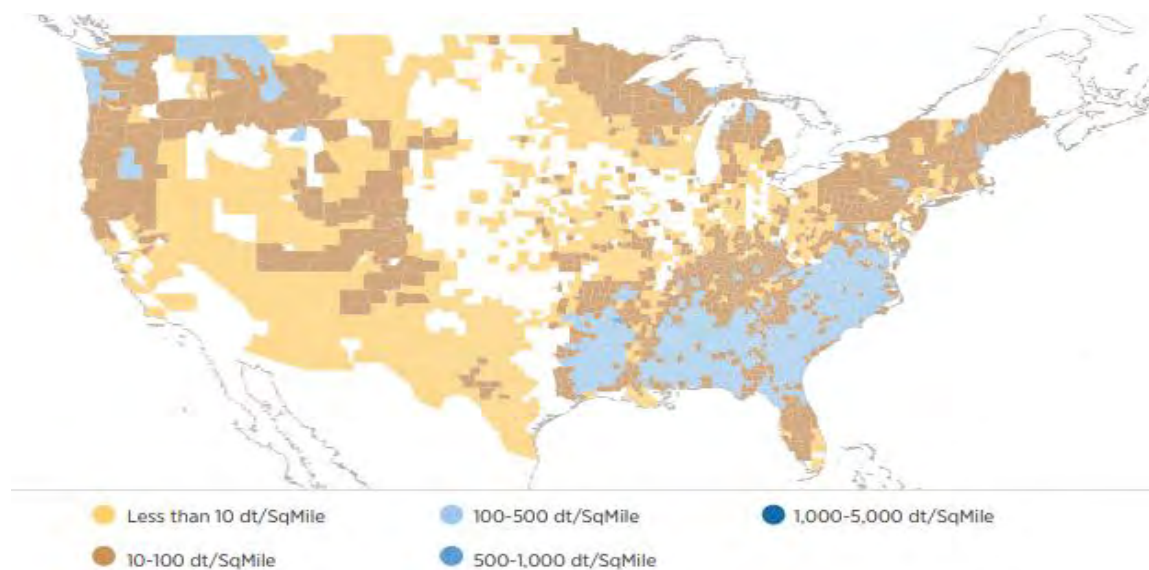

Source: DOE, 2016, p. xix.

Woody biomass is mechanically processed into chips using chippers either on-site (i.e., in the forest); at dedicated chip manufacturing facilities; or in saw, pulp, paper, or pellet mills. Feedstocks for wood pellets may consist of recycled wood chips or residues captured from other wood product manufacturing processes (i.e., saw dust from lumber mills, forest residuals, and from logs). *Exhibit 9-8* illustrates the location and production capacity of operational sawmills in the United States as of 2018.

EXHIBIT 9-8: Operational Sawmill Capacity, 2018



Source: Wood2Energy, 2018.

Wood Pellet Plants

Small- and medium-scale plants, producing largely wood pellets for the domestic heating market, are concentrated in the Northeast and Northwest; large-scale, export-oriented industrial wood pellet producers are located in the Southeast. The Midwest has little to no pelleting capacity. At the end of 2019, the U.S. pellet industry had an operational production capacity of more than 15 million metric

tons/year, with an additional 1.3 million metric tons of capacity proposed or under construction. There were 126 operational pellet plants in the United States located in 37 States (Biomass Magazine, 2018). *Exhibit 9-9* illustrates the importance of the Southeastern States, particularly Georgia and North Carolina. The Southeast is leading pellet production in the United States for two reasons. First, its proximity to East Coast ports gives it low-cost access to European markets. Second, the region has established plantation forests, a favorable climate for year-round tree growth, working-forest management expertise, labor, and infrastructure from its history of supplying wood for the wood product, pulp and paper, and furniture industries.

EXHIBIT 9-9: 2018 Operational Wood Pellet Plant Capacity in the United States

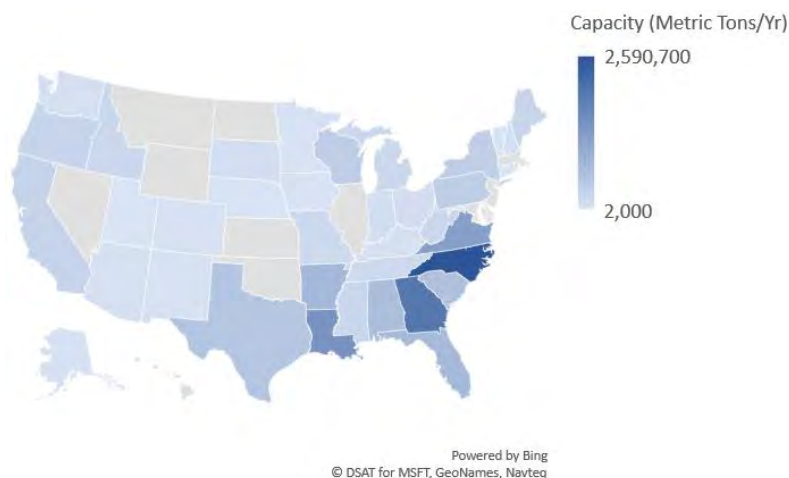

Source: ICF, based on data from Biomass Magazine, 2020.

Exhibit 9-10 provides a snapshot of monthly business survey responses from 90 operating pellet fuel manufacturing facilities in the United States. Launched in 2016, the U.S. Energy Information Administration (EIA) uses this survey to gather data on manufacturers for their Densified Biomass Fuel Report. Production and sales of pellet manufacturers are presented for the month of February 2020.

EXHIBIT 9-10: EIA Monthly Densified Biomass Fuel Report – Survey Data, 2020

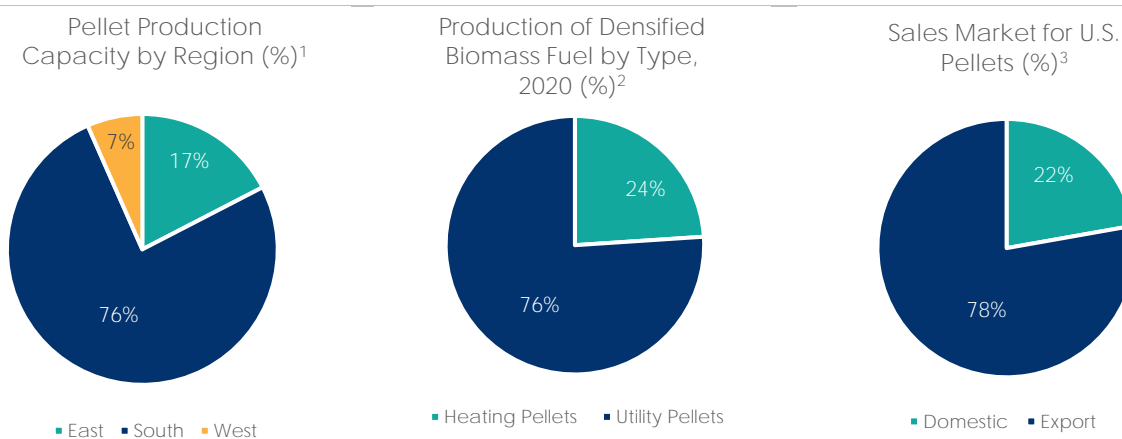

1. Total production capacity for 90 surveyed pellet plants in February 2020 was 11,854,814 short tons/year.
 2. The total production of densified biomass fuel for the 90 surveyed pellet plants in February 2020 was 703,647 short tons.
 3. The total export sales of densified biomass fuel for the 90 surveyed pellet plants in February 2020 was 532,014 short tons at an average price of US\$163.39/ton.
- Source: EIA, 2020.

Exhibit 9-9 and *exhibit 9-10* illustrate the State-level intensity of pellet production in the United States. Residential pellets tend to be produced in cooler climates where predictable increases in the seasonal demand for home heating, along with proximity to adequate forest resources, improve the economics of installing pellet stoves and related equipment. States that provide incentives for pellet stoves and

other combustion equipment may also see additional demand, even if they lack any pellet-producing capacity (e.g., Maryland, Massachusetts, Montana).

INPUT AND PRODUCTION COSTS AND POTENTIAL ENVIRONMENTAL AND LAND USE IMPACTS

Cost of Wood Inputs

The material cost of wood inputs used to make pellets and chips can vary according to factors such as the size and type of wood input used (e.g., hardwood versus softwood), form of wood residue, season, year, and location. Location-based cost factors include the geography, climate, and other site-specific considerations, such as where wood is harvested (e.g., mountains versus open, flat, woody area) and local market conditions. The season can be an important factor in determining where typical climate conditions can be expected to hinder the ability to harvest wood resources. For example, some regions have a “mud” season when it is difficult to get workers and machinery into forests. National, State, and local economic conditions can impact the demand for wood in general. Similarly, with respect to pellets for residential heating, demand dips in non-winter months and so, too, does the associated demand for the wood input.

Since wood chips are a significant input for the pellet industry, their price is a reasonable proxy for the costs of producing pellets. Like pellets, wood chip prices vary by type (e.g., hardwood versus softwood), location, and season. Transportation distances also impact the cost of chips to the end-user. In the Pacific Northwest (PNW), wood is primarily sourced from relatively rugged and/or mountainous areas. The cost of harvesting is greater than that in the Southeast, where wood is often produced in tree farms and mechanically harvested. Additionally, trees grow faster in the Southeast due to its warmer climate and longer growing season. *Exhibit 9-11* shows wood chip costs in the PNW and the U.S. South from 2012 to 2018. At the end of 2018, wood chips cost \$75/dry ton in the Southeast, while prices in the Pacific Northwest were typically around \$100/dry ton (Greene, 2018). Residual chip volatility is higher in the PNW because prices respond more to economic swings that impact the demand for building materials, such as the demand for lumber and paper. In the Southeast, the supply is more stable due to the industrialized nature of wood production. Also, pellet mills in the Southeast tend to have long-term contracts for both their product and their chip supply, which further adds to price stability (Hartley, 2020).

EXHIBIT 9-11: Cost of Residual Wood Chips

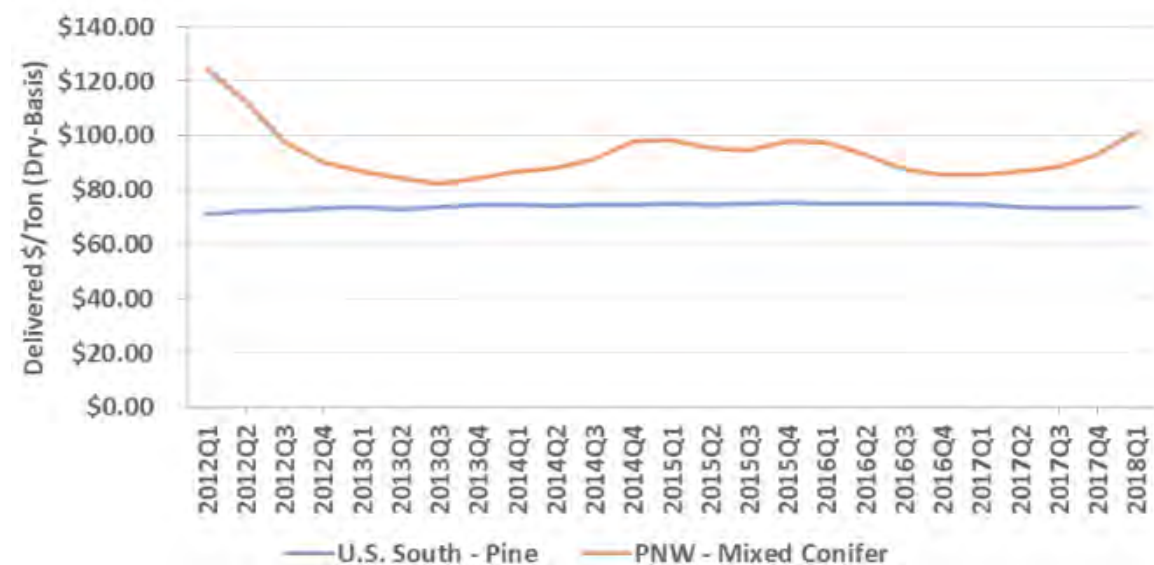

Source: Greene, 2018.

Cost of Production (and Finished Product Cost)

In addition to the cost of wood inputs, other factors that influence the cost of producing wood pellets include the capital costs of the facility, processing costs, and transportation costs.

Large pellet plants can achieve economies of scale. A good average cost to consider when building a green pellet plant (one that receives undried raw material) from start to finish is approximately \$1.2 million to \$2 million dollars per desired short ton per hour. Using these values, a relatively large industrial- or utility-grade pellet plant with 500,000 metric tons/year (550,000 short tons/year) of capacity might cost approximately \$75 million.²⁶⁴ For a similar, but smaller, 100,000-metric ton/year (110,000-short ton/year) pellet plant, the cost would be approximately \$27 million (Vecoplan Midwest, 2016).

One factor in the cost of production is whether a facility has the capability to process the raw materials. Many utility-grade pellet mills and wood chip producers have on-site dedicated wood processing systems (e.g., log barkers and chippers) that enable them to process whole logs, which in turn lowers costs. Other large facilities contract with large chip suppliers. These dedicated chipping facilities may also be associated with pulp and paper mills that would then convert the chips to pulp and/or paper.

On the other hand, smaller facilities, as are typical with residential heating pellet manufacturers, do not have in-house equipment to process whole logs. Smaller manufacturing facilities tend to purchase their raw material from local suppliers, such as sawmills and/or local foresting operations.

Because almost all utility-grade pellets are exported to European markets, another factor in the cost of production is the location of the manufacturing facility relative to the intended user or export port. According to the U.S. DOE, the per mile transportation cost for chips is \$0.046/dry ton for a loaded truck and \$0.028/dry ton for an empty truck (DOE, 2016). Exhibit 9-13 illustrates that the price of utility-grade pellets has been in the \$200/metric ton range in recent years. This includes the cost of raw materials at their source, transportation of those materials, pellet production costs, and pellet transportation to the end-user.

EXHIBIT 9-13: Estimated Prices for Pellets From North America and Europe (\$/metric ton)

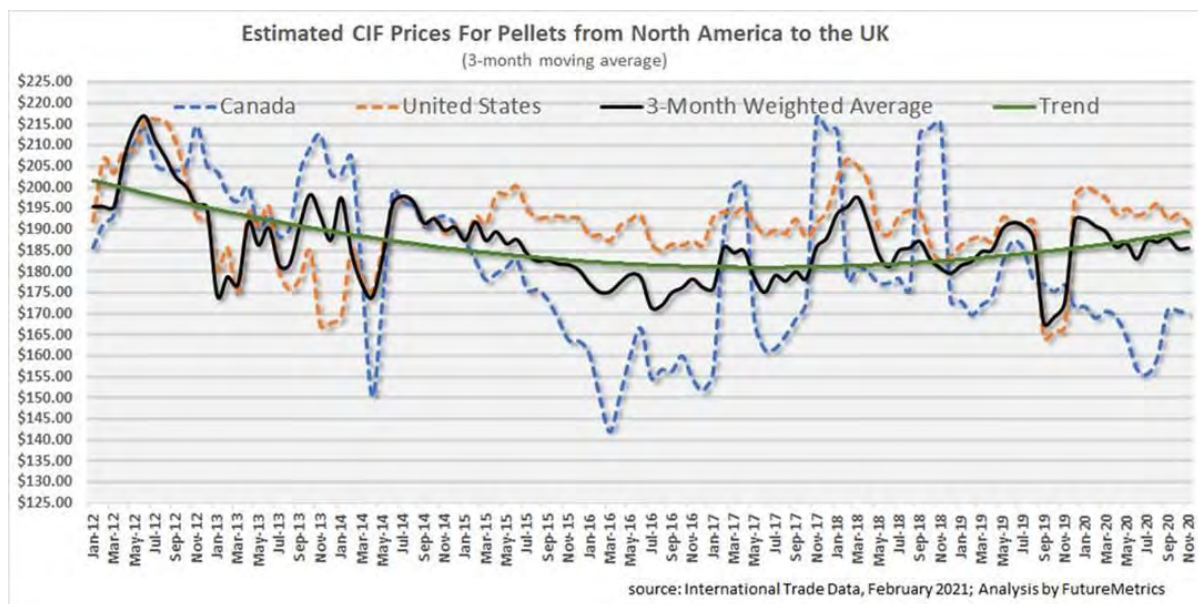

Source: FutureMetrics LLC, 2021.

²⁶⁴ $\frac{550,000 \text{ short tons}}{\text{year}} \div \frac{8,760 \text{ hours}}{\text{year}} \times \frac{\$1.2 \text{ million}}{\text{tons/hour}} = \$75.4 \text{ million in capital cost}$

Potential Environmental and Land Use Impacts

To the extent that wood pellets and wood chips are harvested in a sustainable manner, biomass power generation systems using these wood sources as feedstocks are likely to reduce greenhouse gas emissions compared to fossil fuel sources. However, the combustion of wood to produce electricity can also cause non-carbon particulate and/or gaseous emissions. If not properly controlled, those combustion emissions can be harmful to the environment. Further, the wood pelletizing process can generate volatile organic compounds (VOCs) and/or particulate emissions if not properly controlled, and stored pellets can emit VOCs if not managed properly (Biomass Magazine, 2015).

If there are increases in wood pellet demand, that may shift forestry patterns (e.g., by encouraging retention of timberlands) which, in turn, may shift urban expansion towards agricultural lands in certain regions (Duden et al., 2017). Decreases in wood pellet demand can have the opposite effect, triggering a reduction in timberlands (Duden et al., 2017).

REFERENCES

- Abt et al. 2014. Effect of Policies on Pellet Production and Forests in the U.S. South. U.S. Forest Service. Abt, K. L., Abt, R. C., & Galik, C. S. https://www.srs.fs.usda.gov/pubs/gtr/gtr_srs202.pdf [accessed December 2018].
- BERC. 2019. *Wood Chip Fuel Specifications*. Biomass Energy Resource Center. https://www.biomasscenter.org/images/stories/Woodchip_Heating_Fuel_Specs_electronic.pdf [accessed March 2019].
- Billing et al. 2017. *Hydrothermal Processing of Biomass, Peer Review*. Billing, J., Hallen, R., & Schmidt, A. https://www.energy.gov/sites/prod/files/2017/05/f34/waste_to_energy_billing_222301.pdf [accessed February 2019].
- Biomass Magazine. 2015. Pellet Plant VOCs: Best Practices in Control. <http://biomassmagazine.com/articles/11579/pellet-plant-vocs-best-practices-in-control> [accessed August 2020].
- Biomass Magazine. 2018. Forecasting Industrial Wood Pellet Prices. <http://biomassmagazine.com/articles/15610/forecasting-industrial-wood-pellet-prices> [accessed February 2019].
- Biomass Magazine. 2020. U.S. Pellet Plants. <http://biomassmagazine.com/plants/listplants/pellet/US/Operational> [accessed April 2020].
- Canadian Biomass Magazine. 2017. Global Pellet Market Outlook in 2017. <https://www.canadianbiomassmagazine.ca/growing-demand-for-pellets-6074/> [accessed December 2018].
- DBFZ. 2017. DBFZ work out IEA study on wood pellet market in more than thirty countries. Deutsches Biomasseforschungszentrum gemeinnützige GmbH. <https://www.dbfz.de/en/press-media-library/press/press-releases-2017/press-release-10072017/> [accessed May 2020].
- DOE. 2016. *Billion-Ton Report: Advancing Domestic Resources for a Thriving*. U.S. Department of Energy. <http://energy.gov/eere/bioenergy/2016-billion-ton-report> [accessed January 2019].
- Duden et al. 2017. Modeling the Impacts of Wood Pellet Demand on Forest Dynamics in Southeastern United States. *Biofuels, Bioproducts and Biorefining*. <https://onlinelibrary.wiley.com/doi/full/10.1002/bbb.1803> [accessed August 2020].
- Edwards, D. 2019. Interview with D. Edwards, Peterson Inc., by J. Lukas, ICF. February 2019.
- Efficiency Maine. 2019. Biomass Boilers and Furnaces. <https://www.energymaine.com/at-home/biomass-boilers-furnaces/> [accessed February 2019].
- Efficiency Vermont. 2019. Central Wood Pellet Furnaces & Boilers. <https://www.energymaine.com/rebates/list/central-wood-pellet-furnaces-boilers-business> [accessed February 2019].
- EIA. 2019. Biomass Explained - Wood and Wood Waste. U.S. Energy Information Administration. <https://www.eia.gov/energyexplained/biomass/wood-and-wood-waste.php> [accessed July 2019].
- EIA. 2020. Manufacturing facilities with capacity and status, February 2020. U.S. Energy Information Administration. <https://www.eia.gov/biofuels/biomass/> [accessed April 2020].
- Energy Star. 2018. Federal Tax Credits: Biomass Stoves. https://www.energystar.gov/about/federal_tax_credits/biomass_stoves [accessed December 2018].
- European Commission. 2020. Renewable Energy Directive. https://ec.europa.eu/energy/topics/renewable-energy/renewable-energy-directive/overview_en#sustainable-biofuels [accessed April 2020].
- FutureMetrics LLC. 2021. Estimated CIF Prices for Pellets from North America to the UK. Note: Image provided by the author.
- Greene, J. 2018. Chip & Pulpwood Price Trends in the US South & PNW. Forest2Market. <https://blog.forest2market.com/chip-pulpwood-price-trends-in-the-us-south-pnw> [accessed December 2018].
- Hartley, D. 2020. Interview with D. Hartley, Group Lead for Biomass Analysis - Idaho National Laboratory, by J. Lukas, ICF. May 2020.
- Idaho National Laboratory. 2017. *U.S. Pellet Industry Overview*. U.S. Department of Energy. https://inldigitalibrary.inl.gov/sites/sti/sti/Sort_1078.pdf [accessed May 2020].
- Maryland Energy Administration. 2019. Clean Burning Wood and Pellet Stove Rebate Program. Maryland Energy Administration: <https://energy.maryland.gov/residential/Pages/incentives/woodstoves.aspx> [accessed February 2019].
- Massachusetts Clean Energy Center. 2019. Commonwealth Woodstove Change-Out. <https://www.masscec.com/commonwealth-woodstove-change-out> [accessed February 2019].
- Montana Department of Environmental Quality. 2017. *Energy Tax Credits Fact Sheet - Biomass (Wood) Stoves*. <https://deq.mt.gov/Portals/112/Energy/Documents/Biomass.pdf?ver=2017-10-18-131734-277> [accessed February 2019].

- NYSERDA. 2019. Residential Pellet Stove. New York State Energy Research and Development Authority. <https://www.nyserdera.ny.gov/All-Programs/Programs/Renewable-Heat-NY/Residential-Wood-Pellet-Stove> [accessed February 2019].
- Portz, T. 2018. Interview with T. Portz, Executive Director of PFI, by J. Lukas, ICF. December 2018.
- Puget Sound Clean Air Agency. 2019. Puget Sound Wood Stove Program. <https://www.pscleanair.org/409/Wood-Stove-Program> [accessed February 2019].
- Thrän et al. 2018. The Dynamics of the Global Wood Pellet Markets and Trade - Key Regions, Developments and Impact Factors: The Rise of the Global Wood Pellet Market, the Intensification of Trade and Future Challenges Scrutinized in Detail. *Biofuels, Bioproducts and Biorefining*. Thrän D., Schaubach, K., Peetz, D., Junginger, M., Mai-Moulin, T., Schipfer, F., Olsson, O., & Lamers, P. https://www.researchgate.net/publication/327472309_The_dynamics_of_the_global_wood_pellet_markets_and_trade_-_key_regions_developments_and_impact_factors_The_rise_of_the_global_wood_pellet_market_the_intensification_of_trade_and_future_challenges_scru [accessed June 2020].
- USDA. 2016. *Sustaining Forests*. U.S Department of Agriculture, Forest Service. https://www.nrs.fs.fed.us/sustaining_forests/conserve_enhance/biodiversity/biomass/ [accessed February 2021].
- Vecoplan Midwest. 2016. *So You Want to Make Pellets?* <https://www.vecoplanmidwest.com/wp-content/uploads/2016/06/Pellet-Mill-Startup-Paged.pdf> [accessed January 2019].
- Vermont Energy Investment Corporation. 2018. Wood Stove Incentive. <http://www.nerc-vt.org/wood-stove-incentive> [accessed February 2019].
- Windham & Windsor Housing Trust. 2019. Do You Qualify for a New Pellet Stove. Home Matters Here. <https://www.homemattershere.org/home-repair/do-you-qualify-for-a-new-pellet-stove/> [accessed February 2019].
- Wood2Energy. 2018. Wood2Energy Geospatial Database. <https://Wood2energy.org> [accessed April 2020].

10. Conclusion

Renewable energy technologies have gained traction over the past few decades and are increasingly being integrated into rural communities and economies. The growth of wind and solar energy systems has created new and expanding revenue streams for landowners and has even helped lower power prices in many parts of the United States. The expansion of corn ethanol, biodiesel, and renewable diesel, as well as the continued use of biomass for heat and electricity, has created increasing demand for agricultural and forestry products such as corn, soybeans, forest products, and wood waste. In addition to the expanding economic opportunities, renewable technologies improve energy security by reducing the need for imported energy products and decrease greenhouse gas (GHG) emissions when they are substituted for fossil fuels (benefiting the environment and human health). These technologies also have potential negative land use and environmental impacts that should be considered alongside their economic, environmental, and other benefits.

This chapter provides a summary of the following:

- The state of renewable technologies
- Growth of renewable energy technologies
- The geographic distribution of renewable technologies
- The cost of renewable energy technologies
- Key Federal and State policies that have shaped renewable energy development
- A look toward future challenges and opportunities for renewable energy as it relates to the agriculture and forestry sectors

STATE OF RENEWABLE TECHNOLOGIES

The current renewable energy landscape includes a combination of established technologies that are widely deployed, established technologies that have limited or moderate deployment, and nascent technologies that are not yet commercially viable.

Established, Widely Deployed Renewable Energy Technologies

Utility-scale wind, solar photovoltaic (PV), and corn ethanol are three renewable energy options that have become increasingly cost-competitive and are now well established within the American energy landscape. Utility-scale wind and solar PV, at all scales, are expected to continue to grow in the coming years, while the domestic use of corn ethanol is expected to remain relatively stable.

Utility-scale wind generation has grown more than 40-fold since 2000, accounting for 7 percent of total utility-scale electricity production in the United States (AWEA, 2020, p. 5; EIA, 2020a). The Federal production tax credit (PTC) has been a key policy driving wind deployment, alongside several State-level Renewable Portfolio Standards (RPS) and Clean Energy Standards (CES) mandating set percentages of renewable or clean energy in State generation mixes. Technological improvements, such as much longer turbine blades and decreases in capital costs, have made large-scale wind technologies increasingly cost-competitive with conventional fossil fuel sources.

Solar PV on all scales (i.e., utility, commercial, and residential) expanded dramatically over the past 12 years, with capacity growing 800-fold (EIA, 2020b, table 6.1.A; EIA, 2019a). This growth has been spurred by significant declines in capital costs for PV systems. PV deployment also has benefited from the Federal investment tax credit (ITC) and State RPS and CES policies.

Corn ethanol production has grown tenfold over the past two decades, with production reaching 16 billion gallons in 2018 (USDA, 2019, tables 10 & 16). The most influential policy for the development of the corn ethanol market is the Federal Renewable Fuel Standard (RFS), which was established in 2005 and sets targets for ethanol blending with gasoline. Although the RFS has been a key driver of production in past years, the 15-billion-gallon limit for ethanol produced from corn kernel starch is expected to limit

continued growth.²⁶⁵ In addition, until July 2019, there were limitations on the sale of blends above 10 percent during the summer months to limit evaporative emissions. As a result, relatively few retail service stations are equipped to store and dispense blends above E10. The lack of infrastructure to distribute E15 to customers also will limit the rate of growth of corn ethanol in the coming decade.

Established, Moderate-Deployment Renewable Energy Technologies

Distributed wind energy systems, anaerobic digesters, bioelectricity, biodiesel, and renewable diesel are mature technologies that have had moderate to low deployment, largely due to their comparatively high capital costs relative to other options. Wood chips and wood pellets are a feedstock in this deployment category. Additional Federal or State policy support (e.g., grants, loan guarantees) may be necessary to encourage expansion of these technologies and feedstocks.

Although utility-scale wind energy now makes up a significant portion of U.S. generation, use of entity-scale wind systems remains limited. Distributed wind energy systems make up approximately 1 percent of the total U.S. wind energy capacity, the majority of which is comprised of larger turbine systems within this market segment (i.e., greater than 1 megawatt [MW] of capacity) (DOE, 2019a, p. 7). The deployment of distributed wind systems is limited by the higher capital costs per kilowatt generated (NREL, 2016, p. 15). Continued support for technology improvements, such as through the U.S. Department of Energy's Distributed Wind Competitiveness Improvement Project, are important to support the growth of distributed wind energy generation (DOE, 2019b).

As of March 2020, there were 255 operational anaerobic digester (AD) systems on U.S. livestock farms, with the majority on confined dairy and swine operations (EPA, 2020). The potential for profitable AD systems in the dairy and swine sectors is more than 30 times higher than current deployment levels (EPA, 2018, p. 4). Those livestock farms considered to have the best economic potential for AD "are large operations (500 or more milking cows or 2,000 or more swine) that use liquid or slurry manure handling systems and collect manure from animal confinement areas" (EPA, 2018, p. 7). The number of AD systems on livestock farms has remained nearly constant for the past 8 years, due in large part to the decline in market prices for natural gas—the product for which AD-produced biogas substitutes (EPA, 2017, p. 11).²⁶⁶ Policies mandating lower carbon fuels could incentivize increased adoption of AD systems in the future.

Bioenergy power generation output and capacity have remained relatively unchanged in recent years. Between 2014 and 2018, net annual electricity production from bioenergy (biomass and biogas) feedstocks declined by 3 percent in aggregate to 61,901 gigawatt-hours (GWh) (DOE, 2020a, p. 78).²⁶⁷ Bioenergy power generation capacity in 2018 was 15,563 MW (DOE, 2020a, p. 78). Bioenergy electricity generation is expected to remain stable unless investment is made into improving technology performance and making bioenergy power more cost-competitive with conventional utility power.

As of 2018, wood chips and pellets represent approximately 2 percent of total U.S. annual energy consumption (EIA, 2019b). Domestic use of wood chips and pellets, largely as a fuel in residential heating stoves, is established and relatively stable; growth in the markets for these fuels is largely driven by increases in European demand related to the European Union's (EU) Renewable Energy Directive (Canadian Biomass Magazine, 2017).

Federal policies such as the RFS and biodiesel tax credit have played a significant role in encouraging growth of biodiesel and renewable diesel. Biodiesel production has grown from 9 million gallons in the early

²⁶⁵ The 15-billion-gallon limit on corn ethanol is not a set limit, but rather the remaining volume after subtracting the set volume requirements for cellulosic and other advanced biofuels.

²⁶⁶ Low milk prices, interconnection issues, and market and policy uncertainties are identified as other barriers to AD system growth (EPA, 2017, p. 12).

²⁶⁷ 1 GWh = 1,000 megawatt-hours (MWh) = 1,000,000 kilowatt-hours (kWh).

2000s to 1.7 billion gallons in 2019 (EIA, 2020c, table 10.4). The biodiesel and renewable diesel markets have the potential for continued growth if there is investment in expanding transportation and retail infrastructure.

Nascent Renewable Energy Technologies

Agricultural and forestry energy crops, such as switchgrass, Miscanthus, poplar, and willow, have had limited commercial production to date. The cost to utilize these crops for energy remains high relative to fossil fuel alternatives. Additional government incentives and increased research and development will likely be needed to bring these feedstocks to a point of commercial viability.

Although combustion-based biomass power generation is a mature technology, the adoption of biomass gasification technologies has been limited in the United States and globally. Additional policy incentives, at either the Federal or State level, would be needed to expand deployment of this technology beyond pilot projects.

GROWTH OF RENEWABLE ENERGY TECHNOLOGIES (2000–2019)

Exhibit 10-1 shows changes in net annual U.S. electricity generation from biomass (wood and wood-derived fuels), PV, and utility-scale wind between the beginning of 2000 and end of 2019 (in 5-year increments). As the performance of wind and PV technologies has improved and the capital costs have decreased, there has been a corresponding increase in net annual generation. PV, which generated less than 20 GWh annually before 2006, rapidly scaled up to produce 104,057 GWh by 2019 (EIA, 2020b, table 1.1.A; EIA, 2012, table 1.1.A). Conversely, biomass power generation from wood and wood-derived feedstocks remained relatively constant over these two decades, but with modest increases and decreases in different timeframes.

EXHIBIT 10-1: Change in Net Annual Generation of Renewable Electricity, 2000–2019²⁶⁸

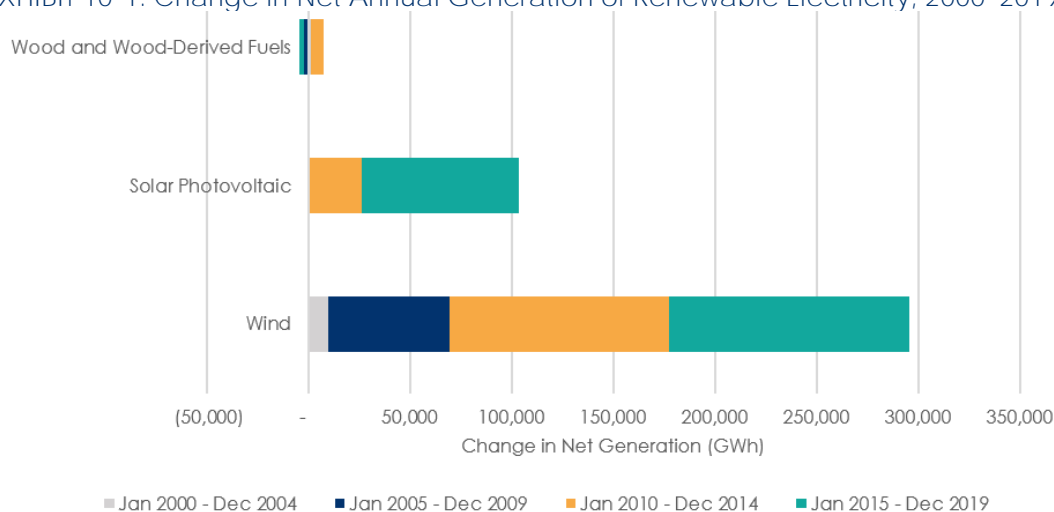

Sources: EIA, 2020b, table 1.1.A; EIA, 2012, table 1.1.A.

Exhibit 10-2 shows the changes in net fuel production for corn ethanol and biodiesel between 2000 and 2019. Corn ethanol production experienced its most significant growth between 2005 and 2009. The rate of growth has slowed in more recent years due, in part, to the 15-billion-gallon limit for ethanol produced from corn kernel starch and limited infrastructure to support the distribution and retail sale of blends above E10. Additionally, there are questions regarding the willingness of consumers to accept higher ethanol blends.

²⁶⁸ The U.S. Energy Information Administration (EIA) presents data on solar thermal and PV generation in aggregate until 2002 and then disaggregates data for 2003 onwards. To approximate solar PV values for 1999 to 2002, solar thermal generation has been subtracted from the pre-2002 values based on the ratio of solar thermal to solar PV in 2003.

EXHIBIT 10-2: Change in Net Annual Fuel Production for Biodiesel and Corn Ethanol, 2000–2019²⁶⁹

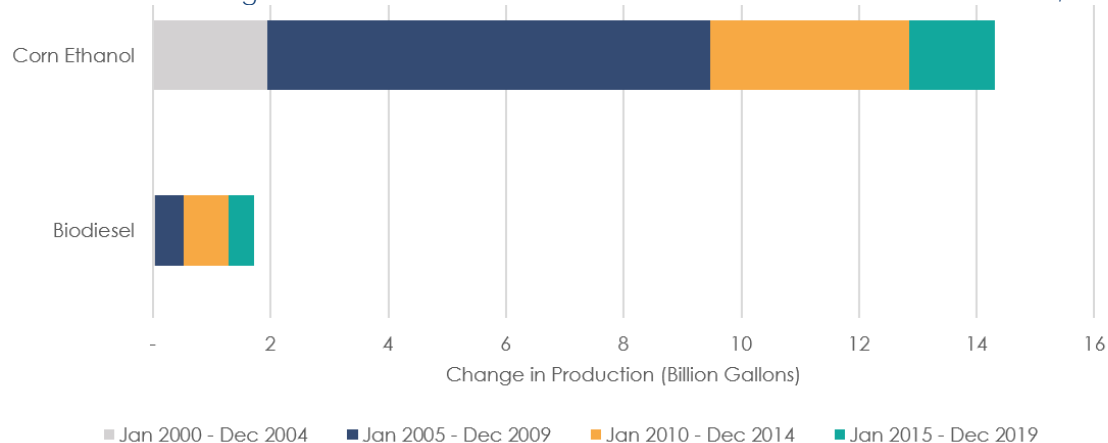

Sources: EIA, 2020c, tables 10.3 & 10.4.

GEOGRAPHIC DISTRIBUTION

The mix of deployed renewable energy systems and technologies varies by region of the country, depending on factors such as resource availability, proximity to feedstock crops, and the influence of State-level incentives and policies. For example, California leads the Nation in solar electricity generation. This lead is due to the State's abundant solar resources and its strong policies supporting renewable energy production. The Southern Plains States (Texas and Oklahoma) have ample wind resources and account for 35 percent of national wind generation capacity (AWEA, 2020, p. 8). The Midwestern States (including the Northern Plains, Corn Belt, and Lake regions) account for the majority of corn and soybean production and the majority of corn ethanol and biodiesel production. Wood chip and pellet production is largely situated in the Eastern United States, with smaller scale domestic market wood pellet/chip production in the Northeast and Pacific Northwest and large-scale production for export to Europe in the Southeast.

Exhibit 10-3 shows the renewable electricity generation capacity for PV, wind, and bioelectricity by State. Exhibit 10-4 provides an overview of key renewable energy technologies by U.S. Department of Agriculture (USDA) region.

EXHIBIT 10-3: Renewable Electricity Generation Capacity or Production by State

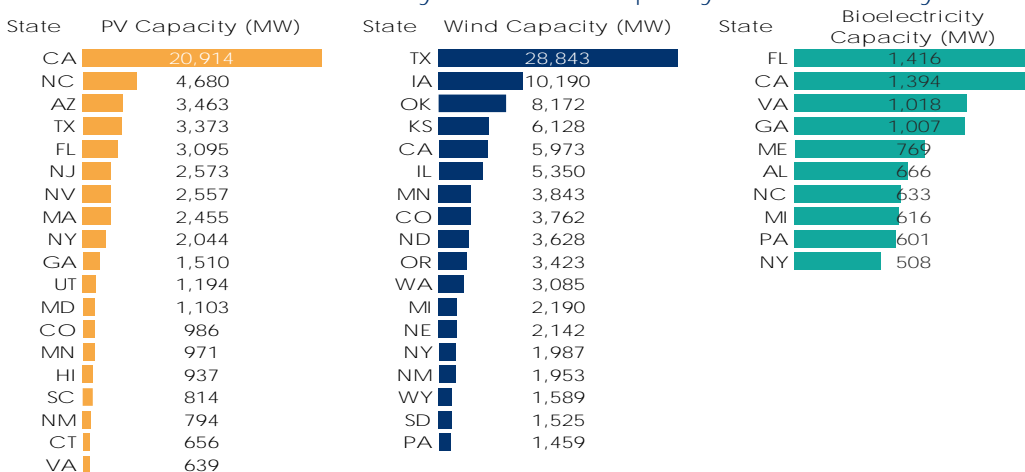

Source: AWEA, 2020, p. 8; EIA, 2020b, table 6.1.A; DOE, 2020a, p. 79.

For PV and wind, States accounting for less than 1 percent of generation capacity have not been listed. For bioelectricity, the ten States with the most generation capacity are listed.

²⁶⁹ There is no comparable production data available for renewable diesel from the U.S. Department of Energy.

EXHIBIT 10-4: Leading Renewable Energy Technologies by Region

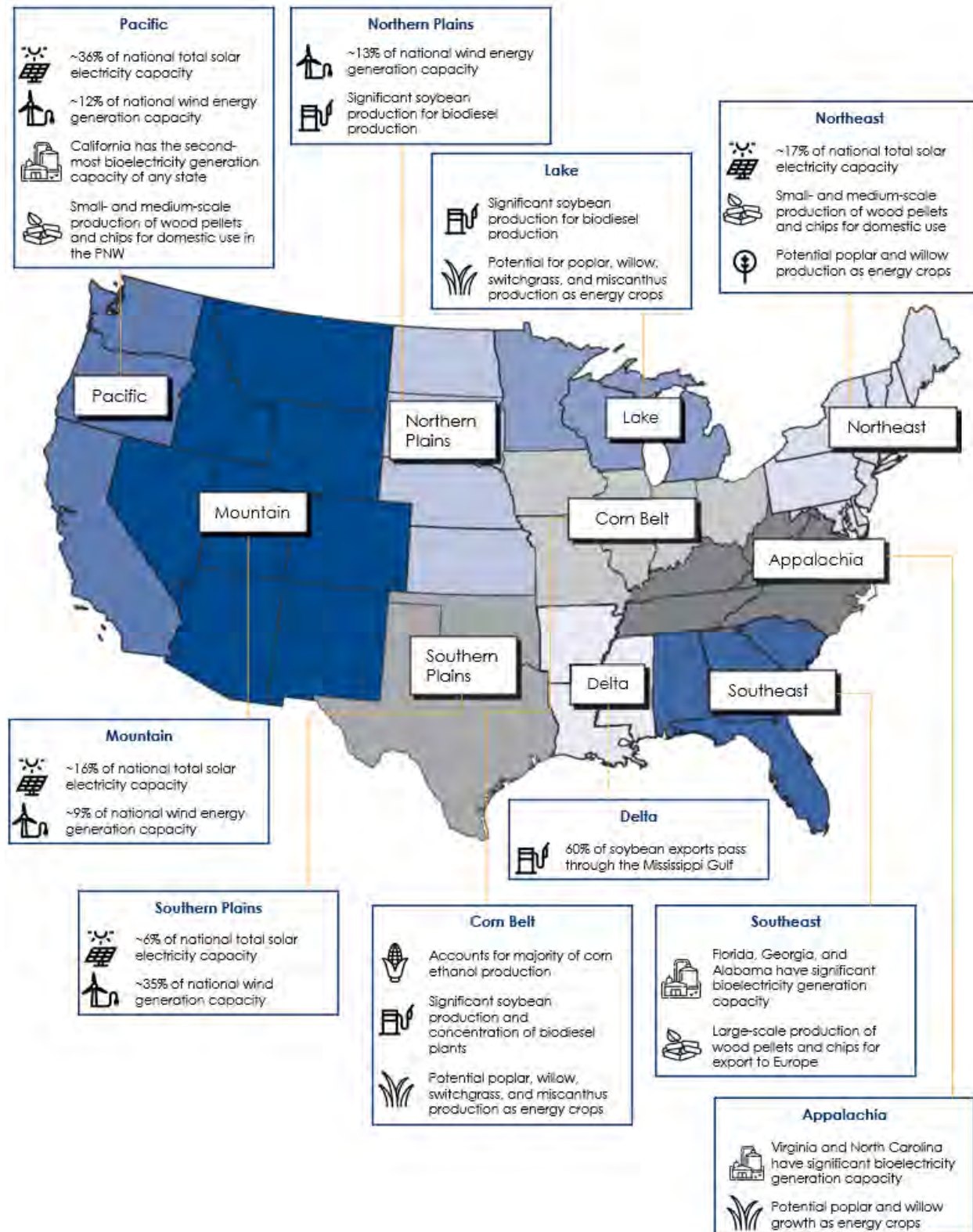

Sources: AWEA, 2020, p. 8; EIA, 2020b, table 6.1.A; DOE, 2020a, p. 79.

COST OF RENEWABLE TECHNOLOGIES

Exhibit 10-5 presents an overview of market size, system cost, and other comparison data for renewable electricity technologies (i.e., bioelectricity, solar PV, and wind), and Exhibit 10-6 provides an overview of the costs associated with the production of renewable liquid biofuels.²⁷⁰ Due to the variation in how renewable technologies are deployed and feedstocks are managed, cost data in these comparison tables should be viewed as broad estimates. In both exhibits, unless otherwise noted, cost data have not been adjusted to 2020 dollars and data are national and correspond to all system sizes.

EXHIBIT 10-5: Comparison of Renewable Electricity Technologies²⁷¹

Attribute	Bioelectricity ²⁷²	Solar PV	Wind	References
U.S. Generating Capacity (MW _{AC})	15,563	58,782	105,583	See technology profiles in the Executive Summary
Annual U.S. Electricity Production in 2019 (GWh)	58,412	104,057	300,071	EIA, 2020b, table 1.1.A
Share of U.S. Electricity Production (Renewable & Non-Renewable Combined) in 2019 ²⁷³	1.4%	2.5%	7.2%	EIA, 2020b, table 1.1. and 1.1.A
Capital Cost (\$/kW) ²⁷⁴	Utility Scale: \$2,000 – \$5,000 (in \$/kW _{AC})	Residential Scale: \$3,500 – \$4,200 Commercial Scale: \$2,200 – \$3,000 Utility Scale: \$1,140 (all PV in \$/kW _{DC})	Utility Scale: \$1,100 – \$1,500 Small & Mid-Sized Distributed Scale: \$2,500 – \$8,000 (in \$/kW _{AC})	See technology profiles in the Executive Summary
Fixed Operations and Maintenance (O&M) Cost (\$/kW) in Year 1 of System Operation ²⁷⁵	Utility Scale: \$50 – \$110	Residential Scale: \$14 – \$25 Commercial Scale: \$15 – \$20 Utility Scale: \$9 – \$12	Utility Scale: \$26 – \$36	
Variable, Non-Fuel O&M Cost (\$/kWh)	Utility Scale: \$0.005	N/A	Small cost; data not readily available	USDA, 2014, p. 8
Fuel Costs (\$/MMBtu)	Utility Scale: \$1 – \$2	N/A	N/A	Lazard, 2017, p. 19
Levelized Cost of Energy (\$/kWh) ²⁷⁶	Utility Scale: \$0.055 – \$0.114	Residential Scale: \$0.151 – \$0.242 Commercial Scale: \$0.075 – \$0.154 Utility Scale: \$0.032 – \$0.044	Utility Scale: \$0.028 – \$0.054	Lazard, 2017, p. 19; Lazard, 2019, p. 3

²⁷⁰ Purpose-grown energy crops are not included in this section. The use of these crops as energy feedstocks has been very limited to date, and existing cost data are few and highly uncertain.

²⁷¹ The units of measure and acronyms used in this exhibit and their equivalencies are as follows: 1 megawatt (MW) = 1,000 kilowatts (kW); 1 gigawatt-hour (GWh) = 1,000 megawatt-hours (MWh) = 1,000,000 kilowatt-hours (kWh); MMBtu = million British thermal units; DC = direct current; AC = alternating current; CO_{2e} = carbon dioxide equivalent.

²⁷² Total generating capacity, annual production, and share of U.S. total electricity production include biogas and biomass sources.

²⁷³ The denominator for this calculation is all U.S. utility-scale electricity production plus U.S. small-scale PV production.

²⁷⁴ Capital costs are the all-in upfront costs (including design, engineering, equipment, labor, permitting, financing, and commissioning) of installing an electricity generation system (before incentives). *Residential scale* refers to small systems at typical households; *commercial scale* corresponds to mid-sized systems at agricultural, forestry, or other commercial or industrial facilities; and *utility scale* refers to the largest systems used to produce power for resale in wholesale electricity markets (by utilities or other generation suppliers).

²⁷⁵ Fixed O&M costs for power generation systems typically increase annually after year 1 with general price inflation.

²⁷⁶ Levelized cost of energy (LCOE) is a metric to compare the long-term costs of generating electricity from different renewable and non-renewable sources. LCOE combines capital costs, O&M costs, system performance (how much electricity is produced annually relative to capacity), and risk-adjusted expected investment returns. The LCOE data shown are without Federal incentives.

Attribute	Bioelectricity ²⁷²	Solar PV	Wind	References
U.S. Employment	13,178 ²⁷⁷	248,034	114,774	NASEO, 2020, pp. 56, 60, & 81
Annual Greenhouse Gas (GHG) Emission Reductions From 10-MW _{AC} System in Example States (metric tons of CO ₂ e) ^{278,279}	KY: 60,179 FL: 31,069 WA: 6,555 (assuming biomass as carbon neutral)	KY: 18,236 FL: 9,415 WA: 1,986	KY: 25,385 FL: 13,106 WA: 2,765	See detailed descriptions in chapters 3–5
Baseload Generation Source ²⁸⁰	Yes, if feedstock supply is stable	No	No	N/A

As can be seen in *Exhibit 10-5*, utility-scale PV and wind have achieved comparatively lower capital costs and O&M costs relative to bioelectricity and, thus, have been adopted at higher rates. At smaller scales, capital costs for residential- and commercial-scale PV tend to be lower than for small and mid-sized distributed wind. The lower cost and greater flexibility in siting are among the reasons that PV is more popular than wind for entity-scale renewable energy generation.

Annual production of corn ethanol is currently 16 billion gallons, compared to 1.7 billion gallons of biodiesel. As illustrated in *Exhibit 10-6*, corn ethanol has achieved greater economies of scale; the levelized cost of fuel for corn ethanol production is currently half that of biodiesel (largely due to the difference in feedstock costs).

EXHIBIT 10-6: Comparison of Renewable Liquid Biofuel Technologies

Attribute	Corn Ethanol	Biodiesel	References
Annual U.S. Production Volume (gallons)	16 billion	Biodiesel: 1.7 billion Renewable Diesel: Not reported ²⁸¹	USDA, 2019, tables 10 & 16; EIA, 2020c, table 10.4; EIA, 2019c
Fuel Yield	490 gallons/acre of corn ²⁸²	57 gallons/acre of soybean	AGMRC, n.d.
Capital Cost of Representative Refinery ²⁸³	> \$211 million ²⁸⁴	\$47 million	Hofstrand, 2020; Hofstrand, 2019
Feedstock Cost (\$/gallon)	\$1.34	\$2.38	
Variable Fossil Fuel Input Cost (\$/gallon)	Natural gas: \$0.14	Natural gas: \$0.04 Methanol: \$0.13	
Variable, Non-Feedstock and Non-Fuel O&M Cost (\$/gallon)	\$0.22/gallon	\$0.25/gallon	

²⁷⁷ This may not include employees at biomass-fueled combined heat and power plants, which are counted separately (NASEO, 2020, p. 63).

²⁷⁸ The differences among the States in estimated GHG emission reductions from renewables are due to the different carbon intensities of their existing mixes of power generation sources. For example, Kentucky has a relatively coal-intensive generation mix and, therefore, introduction of renewables leads to particularly large reductions in GHG emissions in that State.

²⁷⁹ The differences among renewable technologies in estimated GHG emission reductions are due to different capacity factors. Capacity factor measures the annual production of an electricity generation technology relative to its potential production if it operated at its full rated capacity all year. Bioelectricity technologies have the highest average capacity factors because they do not depend on variable sunlight or wind for their power.

²⁸⁰ Baseload electricity can be generated at consistent levels over long periods. If a biomass power generation system has a reliable, long-term feedstock supply and operational plan, it should be able to serve as a baseload power plant. In contrast, without a means of storing electricity, power from wind and PV systems can vary minute to minute with the availability of wind and sunlight.

²⁸¹ The annual production capacity of renewable diesel plants in the United States was 356 million gallons as of 2018, not including a renewable jet fuel plant (DOE, 2020b).

²⁸² A corn crop yield of approximately 170 bushels per acre is assumed (USDA, 2020).

²⁸³ A 15-year asset lifetime is assumed.

²⁸⁴ Costs are associated with a representative ethanol plant, which produces ethanol and dried distillers grains with solubles (DDGS). Capital costs include all costs associated with site preparation, engineering, permitting, financing, and construction.

Attribute	Corn Ethanol	Biodiesel	References
Fixed O&M Cost Over the Asset Life (\$/gallon of capacity) ²⁸⁵	50 MMGPY: ²⁸⁶ \$0.43 100 MMGPY: \$0.21	\$0.26	
Co-Product Revenue Over the Asset Life (\$/gallon of capacity)	\$0.41 ²⁸⁷	N/A	
Levelized Cost of Fuel (\$/gallon) ²⁸⁸	50 MMGPY: \$1.72 100 MMGPY: \$1.50	\$3.06	
U.S. Employment	68,684 direct jobs in 2019	2,500 direct jobs in 2017	RFA, 2020; FTI Consulting, 2018, p. 9

KEY RENEWABLE ENERGY POLICIES AND INCENTIVES

Different technologies have been influenced by different mixes of Federal and State policies and incentives. The first renewable energy policies were introduced in the 1970s, including the Public Utility Regulatory Policies Act of 1978 (PURPA) and the Energy Tax Act of 1978. These acts were subsequently amended or expanded and have played a key role in establishing renewable electricity technologies. Starting in the 1990s, States began adopting RPS and CES, which further incentivized regional development. Most States now have an RPS or CES program in place. Seven States (California, Hawaii, Maine, Nevada, New Mexico, New York, and Washington State), Puerto Rico, and Washington, DC have established zero-carbon targets toward mid-century (UCLA, 2019, p. 4). If the States stick to these targets, it will motivate continued development and deployment of renewable energy systems over the next three decades.

Exhibit 10-7 presents the growth in net electricity generation (in GWh) for utility-scale wind, solar PV, and electricity from biomass (wood and wood-derived sources) between 1999 and 2019, alongside key Federal and State renewable electricity policies implemented over that time.²⁸⁹

Renewable liquid biofuel policies also began emerging in the 1970s, notably with the passage of the National Energy Act in 1978. The Act was passed with the intent to increase national security and energy independence by calling for increasing quantities of alcohol fuels. In more recent years, the Federal RFS has been a key policy for accelerating renewable fuel development. Low carbon fuel standard (LCFS) policies in large states such as California and Oregon have also played a role in the growth of biofuel production.

²⁸⁵ Fixed O&M costs include maintenance materials and services, direct and indirect labor and benefits, operations management, office and lab expenses, training, travel, and professional consulting fees.

²⁸⁶ MMGPY = million gallons per year.

²⁸⁷ Co-product revenue is specific to an ethanol plant solely producing DDGS.

²⁸⁸ The levelized cost of fuel is a metric used to approximate the price at which a fuel would need to be sold to break even with conventional gasoline (in units of US dollars per gallon of gasoline equivalent).

²⁸⁹ Wood and wood-derived feedstocks comprise the majority of bioenergy electricity generation sources, with biogas (e.g., from landfills), municipal solid waste, and other biomass comprising the other feedstock categories.

EXHIBIT 10-7: Key Federal and State Renewable Electricity Policies and Growth of Electricity Generation

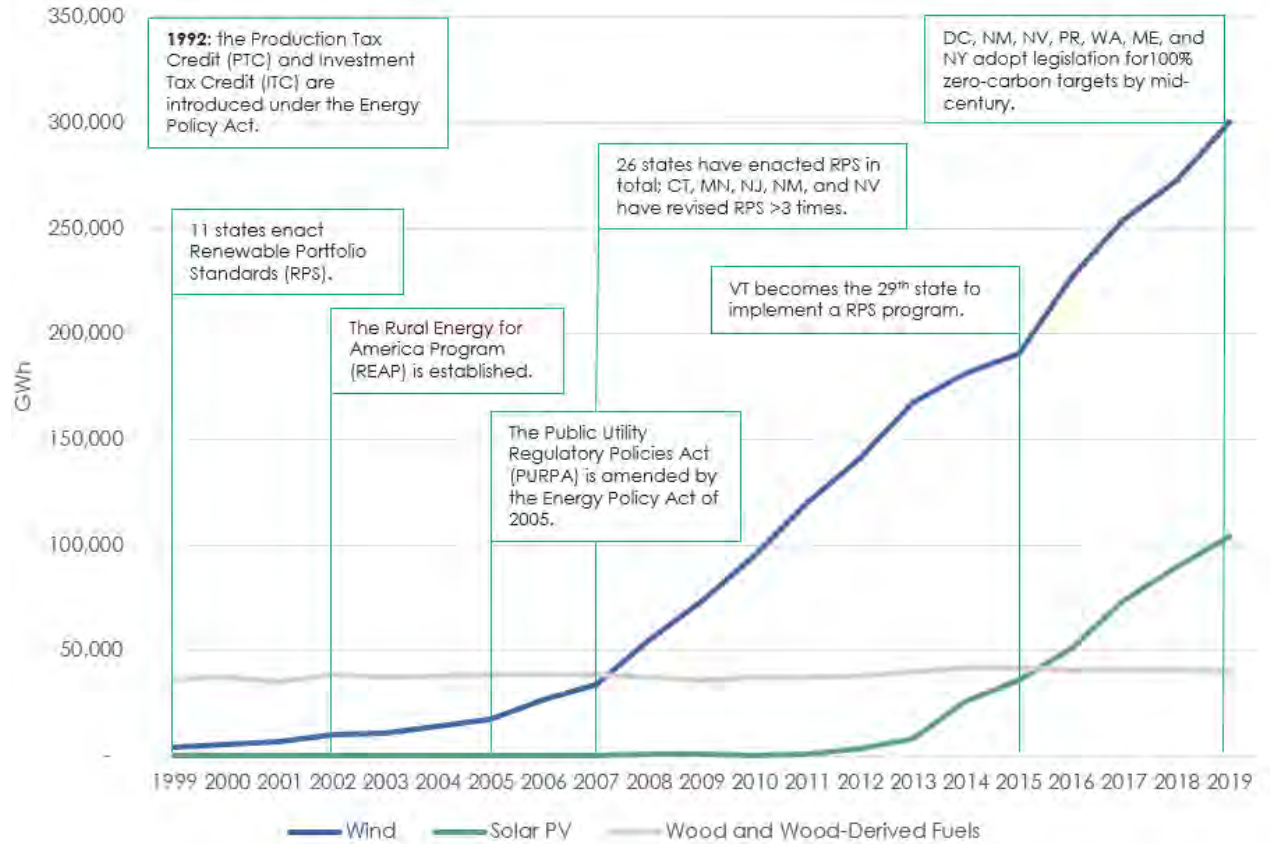

Sources: EIA, 2020b, table 1.1.A; UCLA, 2019; EIA, 2012, table 1.1.A.

Exhibit 10-8 presents the growth in net production of corn ethanol and biodiesel between 1999 and 2019, alongside key Federal and State policies implemented over that time.

EXHIBIT 10-8: Key Federal and State Renewable Liquid Biofuel Policies and the Growth of Production, 1999–2019

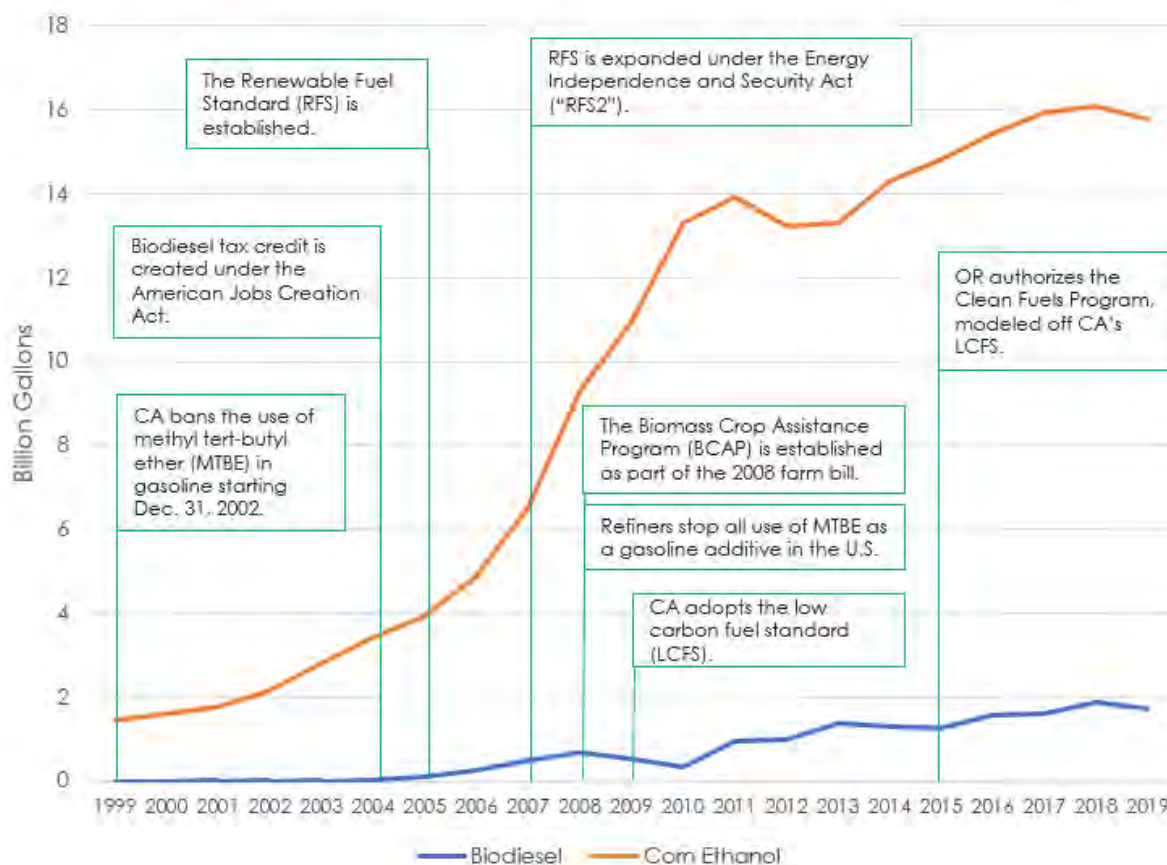

Source: EIA, 2020c, tables 10.3 & 10.4.

THE FUTURE OF RENEWABLE TECHNOLOGIES FOR THE AGRICULTURE AND FORESTRY SECTORS

The diversity of the renewable energy technologies presented in this report provides economic opportunities for agricultural and forestry businesses and rural communities, alongside the benefits of greater energy resiliency and lower carbon emissions. Federal policies (e.g., the investment and production tax credits, RFS, biofuel tax credits) and State policies (e.g., RPS, CES, LCFS, blending mandates) have played an important role in supporting the commercial viability of technologies that were in limited use just two decades ago. Federal and State policies will almost certainly continue to play a role in bringing nascent technologies to commercial viability, as well as continuing to bolster existing technologies. As demand for low-carbon energy options increases, the agriculture and forestry sectors will need to further manage land use and environmental issues, through activities such as integrating traditional agriculture with large-scale solar systems, maintaining soil and water quality with expanded production of energy feedstock crops, minimizing bird and bat mortality with wind turbines, and disposing safely of hazardous materials from solar panels and battery storage systems.

Challenges Facing the Expansion of Renewable Technologies

Looking forward, there are challenges that face the continued development of renewable technologies in rural America, as well as opportunities for continued growth.

Strong growth of wind and solar energy is expected to continue for the next few years, but it may slow thereafter with the planned decline of the solar ITC and the expiration of the wind PTC. Federal tax

incentives have played a key role in supporting wind and solar development and have helped make these renewables cost-competitive with conventional power generation in many parts of the country. However, some of the impact of reduced Federal incentives may be mitigated by the continued decline of capital costs and improvements in solar and wind technology performance.

The ability of electrical grids to integrate increasing shares of intermittently produced power can impede the uptake of more solar and wind energy. As more solar and wind projects come online, electrical grids will face the challenge of integrating these resources without requiring costly load-balancing interventions.

Production and retail infrastructure development are needed to support the continued expansion of liquid biofuels. If renewable diesel and biodiesel markets are to continue to grow, new production facilities are needed to produce larger volumes of the fuels. To make liquid biofuels more available to consumers, continued expansion of retail facilities able to store and dispense higher blends (e.g., E15 and B20) will be needed.

Bioelectricity generation will need to improve performance and its deployment costs to become more competitive with other energy options. The levelized cost of energy for bioelectricity is currently two to four times higher than that of utility-scale wind or solar (see *Exhibit 10-5*). Expansion of bioelectricity generation will require technology innovations and improvements to bring costs down to levels comparable to other renewable energy technologies.

Opportunities for Renewable Energy Technologies

Investment in increasing the performance of distributed wind energy systems could support increased adoption at the residential and commercial scales in rural communities. Technology improvements for utility-scale wind and all scales of solar PV have resulted in significant decreases in cost, allowing for rapid adoption of these technologies over the past two decades. Continued investment in improving efficiency and performance could enable broader adoption of entity-scale wind systems.

Decreases in capital costs for lithium-ion battery storage can support broader adoption of intermittent power sources at all scales. More affordable battery storage can support the integration of more solar PV and wind energy into electric grids. Battery storage also can offer a power backup for residential and commercial entities, which can reduce the risk of interruptions to operations.

Opportunities exist for continued industry growth for liquid biofuels through further expansion into international markets. Several countries now have renewable fuel mandates and incentives for ethanol and biodiesel (e.g., India's 5 percent ethanol blend mandate, Brazil's 12 percent biodiesel blend mandate). More countries may consider increasing the use of renewable fuels as part of their efforts to meet their national commitments to reduce GHG emissions under the United Nations Framework Convention on Climate Change's Paris Agreement. Expanding foreign demand for renewable transportation fuels could offer U.S. ethanol and biodiesel refineries new markets and a reason to significantly expand production.

Opportunities exist for continued growth for industrial wood chips and pellets in foreign markets. The EU's Renewable Energy Directive mandates that a percentage of each member state's energy be generated using renewable sources. The most recent revision of the Renewable Energy Directive established a new binding renewable energy target of 32 percent for the EU by 2030 (European Commission, 2020). This revised mandate is likely to increase European demand for U.S. wood chips and pellets. As with biofuels, other countries may follow and increase the use of utility-grade wood pellets to meet energy needs while reducing GHG emissions.

States are adopting LCFS policies, which will increase domestic demand for lower carbon fuels. California and Oregon were the first two States to adopt LCFS policies. In California, the LCFS has resulted in the carbon intensity of corn ethanol decreasing from 78.28 grams of carbon dioxide

equivalent per megajoule ($\text{gCO}_2\text{e}/\text{MJ}$) in 2011 to $66.01 \text{ gCO}_2\text{e}/\text{MJ}$ today (CARB, 2020). At least 89 ethanol refineries now have approved low-carbon pathways, allowing them to sell ethanol and earn emission reduction credits. Other States, such as New York and Washington State, are now considering a similar LCFS or other low-carbon policies as part of their State climate plans. Significant expansion of State-level LCFS mandates will likely incentivize ethanol and biodiesel refineries to reduce the carbon intensity of their liquid biofuels.

REFERENCES

- AGMRC. n.d. U.S. Corn Usage for Ethanol, Dry Mill Ethanol Co-Products Production, and Ethanol Yields Update. Agricultural Marketing Resource Center. <https://www.agmrc.org/renewable-energy/renewable-energy-climate-change-report/renewable-energy-climate-change-report/february-2018-report/us-corn-usage-for-ethanol-dry-mill-ethanol-co-products-production-and-ethanol-yields-update> [accessed June 2020].
- AWEA. 2020. *U.S. Wind Industry Quarterly Market Report: Fourth Quarter 2019*. American Wind Energy Association. <https://www.awea.org/resources/publications-and-reports/market-reports/2019-u-s-wind-industry-market-reports> [accessed June 2020]. Note: AWEA merged into the American Clean Power Association (ACP) on January 1, 2021.
- Canadian Biomass Magazine. 2017. Global Pellet Market Outlook in 2017. <https://www.canadianbiomassmagazine.ca/growing-demand-for-pellets-6074/> [accessed December 2018].
- CARB. 2020. LCFS Pathway Certified Carbon Intensities. California Air Resources Board. <https://ww2.arb.ca.gov/resources/documents/lcfs-pathway-certified-carbon-intensities> [accessed June 2020].
- DOE. 2019a. 2018 *Distributed Wind Market Report*. U.S. Department of Energy. <https://www.energy.gov/sites/prod/files/2019/08/f65/2018%20Distributed%20Wind%20Market%20Report.pdf> [accessed March 2020].
- DOE. 2019b. *Distributed Wind Competitiveness Improvement Project*. U.S. Department of Energy. https://www.energy.gov/sites/prod/files/2019/02/f60/Distributed%20Wind%20Competitiveness%20Project%20Fact%20Sheet%20FY19_1.pdf [accessed March 2020].
- DOE. 2020a. *2018 Renewable Energy Data Book*. U.S. Department of Energy. <https://www.nrel.gov/docs/fy20osti/75284.pdf> [accessed March 2020].
- DOE. 2020b. Renewable Hydrocarbon Biofuels. U.S. Department of Energy. https://afdc.energy.gov/fuels/emerging_hydrocarbon.html [accessed June 2020].
- EIA. 2012. Electric Power Monthly, Data for 1997 through September 2011. U.S. Energy Information Administration, DOE. <https://www.eia.gov/electricity/monthly/> [accessed June 2020].
- EIA. 2019a. Existing Net Summer Capacity of Other Renewable Sources by Producer Type, 2008 through 2018 (Megawatts). U.S. Energy Information Administration, DOE. https://www.eia.gov/electricity/annual/html/epa_04_02_b.html [accessed June 2020].
- EIA. 2019b. Biomass Explained: Wood and wood waste. U.S. Energy Information Administration, DOE. <https://www.eia.gov/energyexplained/biomass/wood-and-wood-waste.php> [accessed June 2020].
- EIA. 2019c. EIA Expects Stable U.S. Biofuels Production, Consumption, and Trade through 2020. U.S. Energy Information Administration, DOE. <https://www.eia.gov/todayinenergy/detail.php?id=38532#:~:text=EIA%20expects%20stable%20U.S.%20biofuels%20production%2C%20consumption%2C%20and%20trade%20through%2> [accessed June 2020].
- EIA. 2020a. Wind Explained: Electricity Generation from Wind. U.S. Energy Information Administration, DOE. https://www.eia.gov/energyexplained/index.php?page=wind_electricity_generation [accessed June 2020].
- EIA. 2020b. Electric Power Monthly, Data for January 2020. U.S. Energy Information Administration, DOE. <https://www.eia.gov/electricity/monthly/> [accessed April 2020].
- EIA. 2020c. June 2020 Monthly Energy Review. U.S. Energy Information Administration, DOE. <https://www.eia.gov/totalenergy/data/monthly/#renewable> [accessed June 2020].
- EPA. 2017. *Anaerobic Digestion Trends and Successes in the U.S.* U.S. Environmental Protection Agency. https://www.epa.gov/sites/production/files/2017-11/documents/anaerobic-digestion-trends-and-successes-in-the-us_elger.pdf [accessed April 2020].
- EPA. 2018. *Market Opportunities for Biogas Recovery Systems at U.S. Livestock Facilities*. U.S. Environmental Protection Agency. <https://www.epa.gov/sites/production/files/2018-06/documents/epa430r18006agstarmarketreport2018.pdf> [accessed February 2020].
- EPA. 2020. AgSTAR: Livestock Anaerobic Digester Database. U.S. Environmental Protection Agency. <https://www.epa.gov/agstar/livestock-anaerobic-digester-database> [accessed May 2020].
- European Commission. 2020. Renewable Energy Directive. https://ec.europa.eu/energy/topics/renewable-energy/renewable-energy-directive/overview_en#sustainable-biofuels [accessed May 2020].
- FTI Consulting. 2018. *The Biodiesel Industry: Impacts on the Economy, Environment and Energy Security*. https://www.fticonsulting.com/~/_media/Files/us-files/insights/reports/biodiesel-industry-impacts-economy-environment-energy-security.pdf [accessed June 2020].

- Hofstrand, D. 2019. Biodiesel Profitability. Iowa State University. <https://www.extension.iastate.edu/agdm/energy/html/d1-15.html> [accessed August 2019].
- Hofstrand, D. 2020. Ag Decision Maker, D1-10 Ethanol Profitability. Iowa State University. <https://www.extension.iastate.edu/agdm/energy/html/d1-10.html> [accessed June 2020].
- Lazard. 2017. *Lazard's Levelized Cost of Energy Analysis—Version 11.0*. <https://www.lazard.com/media/450337/lazard-levelized-cost-of-energy-version-110.pdf> [accessed June 2020].
- Lazard. 2019. *Lazard's Levelized Cost of Energy Analysis—Version 13.0*. <https://www.lazard.com/media/451086/lazards-levelized-cost-of-energy-version-130-vf.pdf> [accessed June 2020].
- NASEO. 2020. *The 2020 U.S. Energy and Employment Report*. National Association of State Energy Officials and Energy Futures Initiative. <https://static1.squarespace.com/static/5a98cf80ec4eb7c5cd928c61/t/5ee78423c6fcc20e01b83896/1592230956175/USEER+2020+0615> [accessed June 2020].
- NREL. 2016. *Assessing the Future of Distributed Wind: Opportunities for Behind-the-Meter Projects*. National Renewable Energy Laboratory. <https://www.nrel.gov/docs/fy17osti/67337.pdf> [accessed March 2020].
- RFA. 2020. Rural Economy: Ethanol Renewing the Heartland. Renewable Fuels Association. <https://ethanolrfa.org/rural-economy/> [accessed August 2020].
- UCLA. 2019. *Progress Toward 100% Clean Energy in Cities & States Across the U.S.* Luskin Center for Innovation, UCLA. <https://innovation.luskin.ucla.edu/wp-content/uploads/2019/11/100-Clean-Energy-Progress-Report-UCLA-2.pdf> [accessed June 2020].
- USDA. 2014. *Assessment of the National Prospects for Electricity Generation From Biomass*. U.S. Department of Agriculture. https://www.usda.gov/oce/reports/energy/USbiopower_04_2014.pdf [accessed June 2020].
- USDA. 2019. *U.S. Bioenergy Statistics*. U.S. Department of Agriculture. <https://www.ers.usda.gov/data-products/us-bioenergy-statistics/> [accessed June 2020].
- USDA. 2020. *Corn for Grain Yield*. U.S. Department of Agriculture. https://www.nass.usda.gov/Charts_and_Maps/graphics/cornylid.pdf [accessed June 2020].